

624 BLD

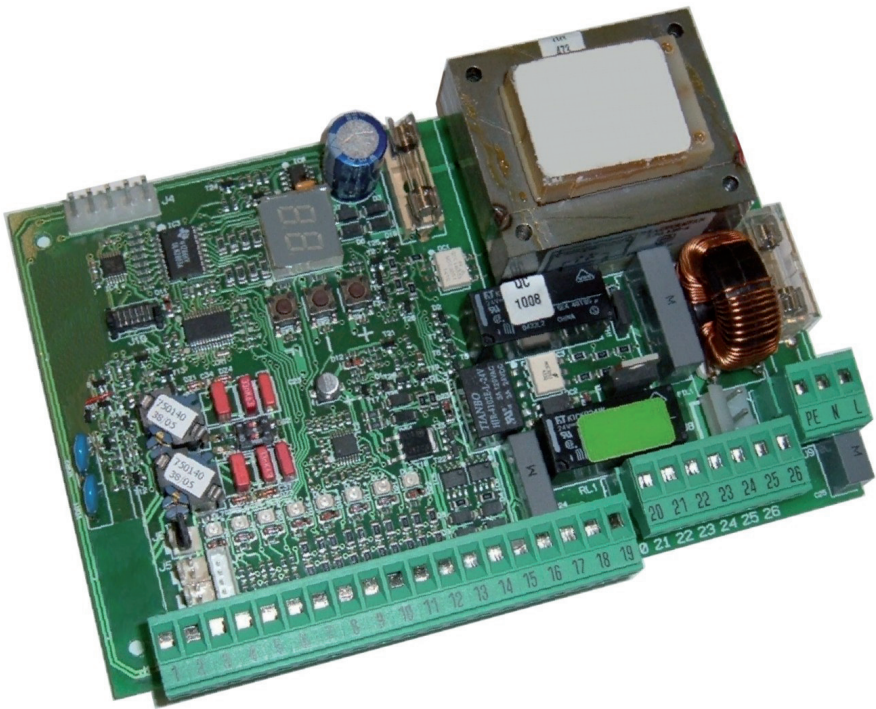

FAAC

INDEX

1...WARNINGS 3

2...TECHNICAL SPECIFICATIONS 3

3...LAYOUT AND COMPONENTS OF 624BLD 3

 3.1 Description of components 3

4...ELECTRICAL CONNECTIONS 4

 4.1 J1 Terminal-board - Accessories (Fig. 2) 4

 4.2 Connection of relay photocells and safety devices with "N.C." contact 5

 4.3 Connection of BUS photocells 5

 4.4 J2 Terminal-board - Motor, flashing lamp and fan (Fig. 2) 6

 4.5 J8 Connector - Motor capacitor (Fig. 2) 6

 4.6 J9 Terminal-board - Power supply (Fig. 2) 6

 4.7 J3, J5 Rapid connectors - for opening and closing limit-switches (Fig. 2)..... 6

 4.8 J6 Connector - Beam breaking sensor (Fig. 2)..... 6

 4.9 DS1 Frequency selector (Fig. 1) 6

 4.10 J4 Connector - for Minidec, Decoder and RP 6

5...PROGRAMMING 6

 5.1 1st LEVEL PROGRAMMING 6

 5.2 Modification of the pre-setting 8

 5.3 Setup and BUS system control 8

 5.4 2nd LEVEL PROGRAMMING 9

 5.5 Setup for integrated Loop Detector 10

6...START-UP 11

 6.1 Board LEDS check 11

 6.2 Check on BUS status 11

7...AUTOMATED SYSTEM TEST 11

8...MASTER-SLAVE CONFIGURATIONS 12

9...3rd LEVEL PROGRAMMING 13

 9.1 Customisation of function logic 15

10.PRE-SETTING VALUES 15

11.NOTES 16

12.INTERLOCK CONNECTION 16

13.FUNCTION LOGIC TABLES 17

CE DECLARATION OF CONFORMITY

Manufacturer: FAAC S.p.A.
Address: Via Calari, 10 - 40069 Zola Predosa BOLOGNA - ITALY
Declares that: 624BLD control unit

- conforms to the essential safety requirements of the following EEC directives

2006/95/EC Low Voltage Directive
 2004/108/EC Electromagnetic Compatibility Directive

Additional note:
 This product underwent tests in a typical uniform configuration
 (all products manufactured by FAAC S.p.A.).

Bologna, 01 January 2010

The Managing Director
 A. Marcellan



ENGLISH

WARNINGS FOR THE INSTALLER GENERAL SAFETY OBLIGATIONS

- 1) ATTENTION! To ensure the safety of people, it is important that you read all the following instructions. Incorrect installation or incorrect use of the product could cause serious harm to people.**
- 2) Carefully read the instructions before beginning to install the product.
- 3) Do not leave packing materials (plastic, polystyrene, etc.) within reach of children as such materials are potential sources of danger.
- 4) Store these instructions for future reference.
- 5) This product was designed and built strictly for the use indicated in this documentation. Any other use, not expressly indicated here, could compromise the good condition/operation of the product and/or be a source of danger.
- 6) FAAC declines all liability caused by improper use or use other than that for which the automated system was intended.
- 7) Do not install the equipment in an explosive atmosphere; the presence of inflammable gas or fumes is a serious danger to safety.
- 8) The mechanical parts must conform to the provisions of Standards EN 12604 and EN 12605.
 For non-EU countries, to obtain an adequate level of safety, the Standards mentioned above must be observed, in addition to national legal regulations.
- 9) FAAC is not responsible for failure to observe Good Technique in the construction of the closing elements to be motorised, or for any deformation that may occur during use.
- 10) The installation must conform to Standards EN 12453 and EN 12445.
 For non-EU countries, to obtain an adequate level of safety, the Standards mentioned above must be observed, in addition to national legal regulations.
- 11) Before attempting any job on the system, cut out electrical power.
- 12) The mains power supply of the automated system must be fitted with an all-pole switch with contact opening distance of 3 mm or greater. Use of a 6A thermal breaker with all-pole circuit break is recommended.
- 13) Make sure that a differential switch with threshold of 0.03 A is fitted upstream of the system.
- 14) Make sure that the earthing system is perfectly constructed and connect metal parts of the closure to it.
- 15) The automated system is supplied with an intrinsic anti-crushing safety device consisting of a torque control. Nevertheless, its tripping threshold must be checked as specified in the Standards indicated at point 10.
- 16) The safety devices (EN 12978 standard) protect any danger areas against **mechanical movement Risks**, such as crushing, dragging, and shearing.
- 17) Use of at least one indicator-light (e.g. FAACLIGHT) is recommended for every system, as well as a warning sign adequately secured to the frame structure, in addition to the devices mentioned at point "16".
- 18) FAAC declines all liability as concerns safety and efficient operation of the automated system, if system components not produced by FAAC are used.
- 19) For maintenance, strictly use original parts by FAAC.
- 20) Do not in any way modify the components of the automated system.
- 21) The installer shall supply all information concerning manual operation of the system in case of an emergency and shall hand over to the user the warnings handbook supplied with the product.
- 22) Do not allow children or adults to stay near the product while it is operating.
- 23) Keep remote controls or other pulse generators away from children, to prevent the automated system from being activated involuntarily.
- 24) Transit is permitted only when the automated system is idle.
- 25) The user must not attempt any kind of repair or direct action whatever and contact qualified personnel only.
- 26) Check at least every 6 months the efficiency of the system, particularly the efficiency of the safety devices (including, where foreseen, the operator thrust force) and of the release devices.
- 27) Anything not expressly specified in these instructions is not permitted.**

CONTROL UNIT 624 BLD

1. WARNINGS

Attention: Before attempting any work on the control unit (connections, maintenance), always turn off power.

- Install, upstream of the system, a differential thermal breaker with adequate tripping threshold.
- Connect the earth cable to the terminal on the J9 connector of the unit (see fig.2).
- Always separate power cables from control and safety cables (push-button, receiver, photocells, etc.). To avoid any electrical noise, use separate sheaths or a screened cable (with the screen earthed).

2. TECHNICAL SPECIFICATIONS

Power supply voltage *	230 V~ (+6% -10%) - 50/60 Hz Or 115 V~ (+6% -10%) - 50/60 Hz
Absorbed power	7 W
Motor max. load	1000 W
Power supply for accessories	24 Vdc
Accessories max. current	500 mA
Operating ambient temperature	from -20°C to +55°C
Protection fuses *	F1 = F 10A - 250V F2 = T 0,8A - 250V Or F1 = F 20A - 120V F2 = T 0,8A - 120V
Work time	Programmable (from 0 to 4 minutes)
Pause time	Programmable (from 0 to 4 minutes)
Motor power	Programmable on 50 levels
Programming	3 programming levels for greater flexibility of use
Rapid connector	Coupling for 5-pin Minidec board, Decoder, Receiver RP/RP2
Programmable outputs	4 programmable outputs in 18 different functions
Features	Management of slow-downs, multifunction display, BUS technology and INTEGRATED METALLIC MASS DETECTOR

* The power supply voltage and fuses depend on the version purchased

3. LAYOUT AND COMPONENTS OF 624BLD

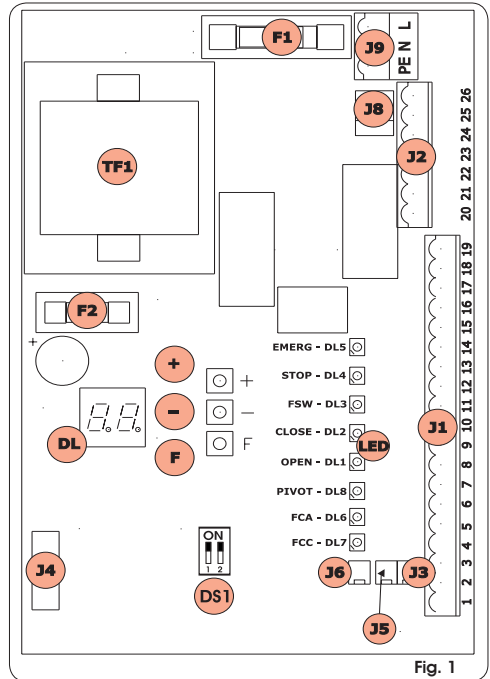

3.1 DESCRIPTION OF COMPONENTS

DL	SIGNALS AND PROGRAMMING DISPLAY
LED	INPUT STATUS CONTROL LEDs
J1	LOW-VOLTAGE TERMINAL BOARD
J2	TERMINAL BOARD FOR CONNECTION OF MOTOR, FLASHING LAMP AND FAN
J3	OPENING LIMIT-SWITCH CONNECTOR
J4	CONNECTOR FOR DECODER MINIDEC / RP RECEIVER
J5	CLOSING LIMIT-SWITCH CONNECTOR
J6	CONNECTOR FOR ROD BREAKING SENSOR
J8	CONNECTOR FOR MOTOR THRUST CAPACITOR
J9	TERMINAL-BOARD FOR 230 VAC POWER SUPPLY
DS1	LOOP 1 and LOOP 2 FREQUENCIES SELECTOR
F1	FUSE FOR MOTORS AND TRANSFORMER PRIMARY WINDING (F 5A)
F2	FUSE FOR LOW VOLTAGE AND ACCESSORIES (T 800mA)
F	PROGRAMMING PUSH-BUTTON "F"
+	PROGRAMMING PUSH-BUTTON "+"
-	PROGRAMMING PUSH-BUTTON "-"
TF1	TRANSFORMER

4. ELECTRICAL CONNECTIONS

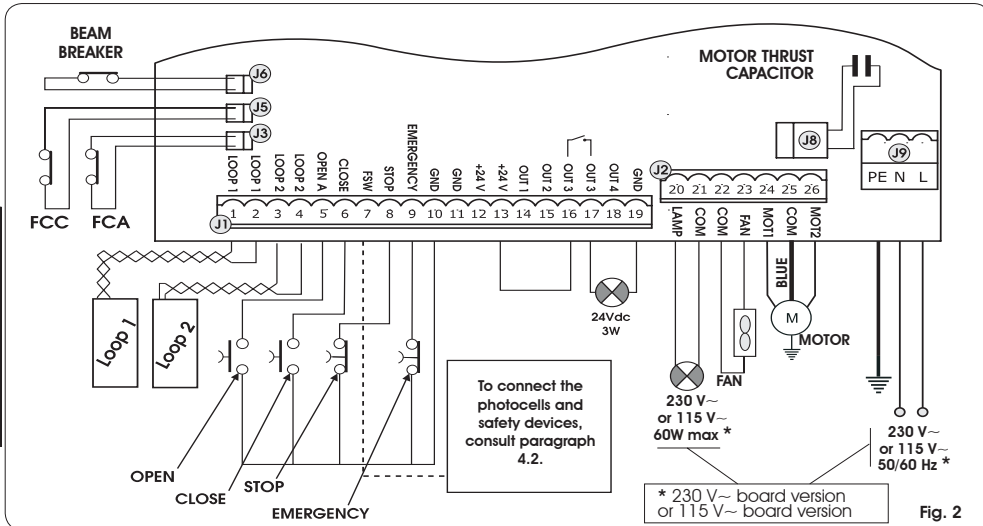

Fig. 2

4.1. J1 TERMINAL-BOARD - ACCESSORIES (FIG. 2)

LOOP 1 - Magnetic loop LOOP 1 (OPEN - terminals 1-2): it activates the OPENING function

LOOP 2 - Magnetic loop LOOP 2 (SAFETY/CLOSE - terminals 3-4): it activates the SAFETY/CLOSING function

OPEN - "Opening" Command (N.O. - terminal 5): this refers to any pulse generator (e.g.: push-button) which, by closing a contact, commands the barrier to close and/or open.

CLOSE - "Closing" Command (N.O. - terminal 6): this refers to any pulse generator (e.g.: push-button) which, by closing a contact, commands the barrier to close.

FSW - Closing safety-devices contact (N.C. - terminal 7). The purpose of the closing safety devices is to protect the barrier movement area during closure, by reversing motion. They are never tripped during the opening cycle. If the closing Safety devices are engaged when the automated system is in open status, they prevent the closing movement.

⚠ If closing safety devices are not connected, jumper connect the FSW and GND terminals (fig. 6).

STOP - STOP contact (N.C. - terminal 8): this refers to any device (e.g.: push-button) which, by opening a contact, can stop the motion of the automated system.

⚠ If stop safety devices are not connected, jumper connect the STOP and GND terminals (fig. 6).

EMERGENCY - EMERGENCY contact (N.C. - terminal 9): this refers to any switch which, by being activated in emergency state, opens the barrier and stops its movement until the contact is restored.

⚠ If emergency safety devices are not connected, jumper connect the EMERGENCY and GND terminals (fig. 6).

GND (terminals 10-11-19) - Negative contact for feeding accessories

24 Vdc (terminals 12-13) - Positive contact for feeding accessories

⚠ Max. load of accessories: 500 mA. To calculate absorption values, refer to the instructions for individual accessories

OUT 1 - Output 1 GND open-collector (terminal 14): The output can be set in one of the functions described in the 2nd programming level (see par. 5.2.). Default value is FAILSAFE. Maximum load: **24 Vdc with 100 mA.**

OUT 2 - Output 2 GND open-collector (terminal 15): The output can be set in one of the functions described in the 2nd programming level (see par. 5.2.). Default value is CLOSED beam. Maximum load: **24 Vdc with 100 mA.**

OUT 3 - RELAY Output 3 (terminal 16-17): The output can be set in one of the functions described in the 2nd programming level (see par. 5.2.). Default value is INDICATOR LIGHT. Maximum load: **24 Vdc or Vac with 500 mA.**

⚠ To avoid endangering correct operation of the system, do not exceed the indicated power indicated in fig. 2.

OUT 4 - Output 4 open-collector +24Vdc (terminal 18): The output can be set in one of the functions described in the 2nd programming level (see par. 5.2.). The default value for ALL THE PRE-SETTINGS is **BUS COMMUNICATION.** Maximum load: **24 Vdc with 100 mA.**

4.2.CONNECTION OF RELAY PHOTOCELLS AND SAFETY DEVICES WITH "N.C." CONTACT

The 624 BLD board envisages the connection of **closing safety devices** which are tripped only during the barrier closing movement, and are therefore suitable for protecting the closing zone against the risk of impact.

⚠ If two or more safety devices (NC contacts) have to be connected, put them in series with each other as shown in figures 3, 4, 5 under the heading "SAFE".

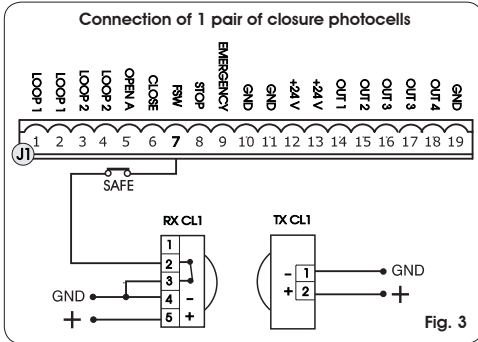

Fig. 3

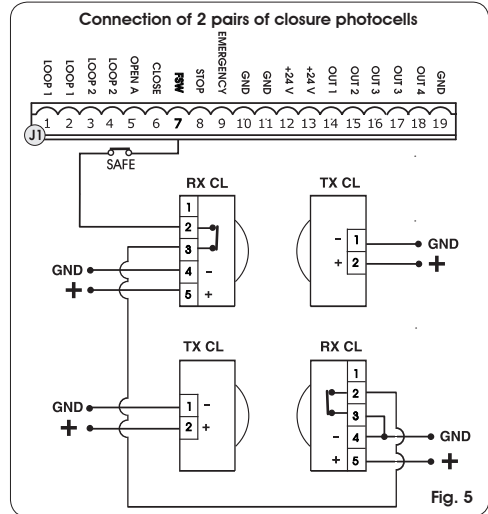

Fig. 5

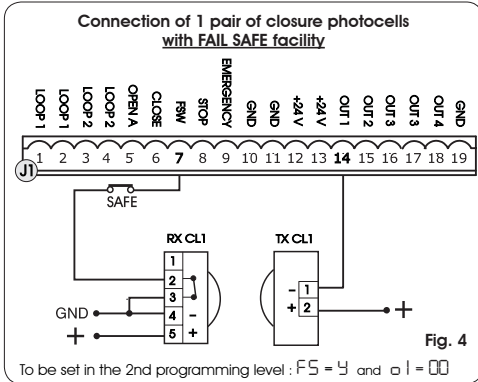

Fig. 4

To be set in the 2nd programming level : FS = 4 and α1 = 00

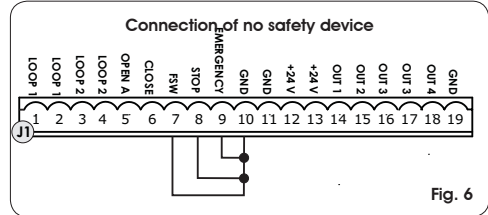

Fig. 6

ENGLISH

4.3.CONNECTION OF BUS PHOTOCELLS

Photocells using BUS technology are connected to the 624 BLD control unit ALL IN PARALLEL as shown in Fig. 7 through single power/communication line.

⚠ The BUS photocells do not have connection polarity.

Up to a maximum of 8 pairs of BUS photocells can be connected to the board. The photocells are subdivided by quantity into the following groups:

- Pairs of closure photocells: max 7
- Pairs of photocells for OPEN pulse: max 1

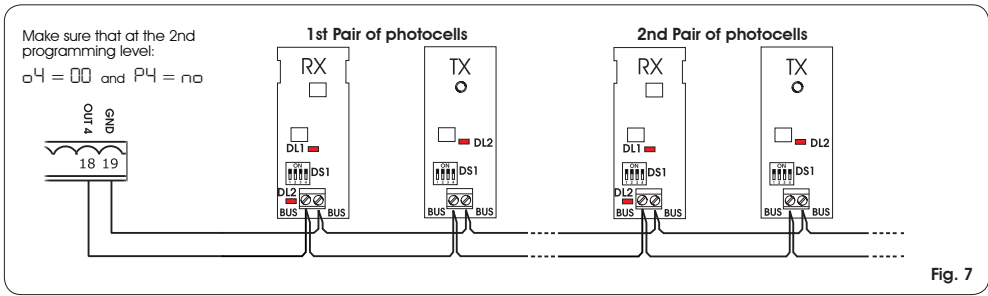

Fig. 7

After positioning of the BUS technology photocells, select the address of each pair through the combination of the DIP-SWITCHES present on each photocell.

⚠ **Set THE SAME DIP-SWITCH ADDRESS chosen on both the transmitter and the receiver of the same pair.**

👉 **Make sure that there are not two or more pairs of photocells with the same address**

👉 **If no BUS accessory is used, leave terminals 18 and 19 free.**

Table 4 shows the programming of the dip-switches present within the transmitter and receiver of the BUS photocells.

Tab. 4 - Address of PAIRS of BUS photocells

DIP-SWITCH TX				← SAME ADDRESS →				DIP-SWITCH RX			
Dip1	Dip2	Dip3	Dip4	Pair number	Type						
ON	OFF	OFF	OFF	1st pair	CLOSURE Photocells						
ON	OFF	OFF	ON	2nd pair							
ON	OFF	ON	OFF	3rd pair							
ON	OFF	ON	ON	4th pair							
ON	ON	OFF	OFF	5th pair							
ON	ON	OFF	ON	6th pair							
ON	ON	ON	OFF	7th pair							
ON	ON	ON	ON	Single Pair	OPEN PULSE						

⚠ **To make the installed Bus accessories operational, perform on-board memorisation as explained in chapter 5.3.**

4.4. J2 TERMINAL-BOARD - MOTOR, FLASHING LAMP AND FAN (FIG. 2)

M (COM-MOT1-MOT2): Motor Connection
LAMP (LAMP-COM): Flashing lamp output
FAN (FAN-COM): Fan output

4.5. J8 CONNECTOR - MOTOR CAPACITOR (FIG. 2)

Rapid connector for connecting the motor thrust capacitor.

4.6. J9 TERMINAL-BOARD - POWER SUPPLY (FIG. 2)

PE : Earth connection
N : Power supply 230 V~ or 115 V~(Neutral)
L : Power supply 230 V~ or 115 V~(Line)

⚠ **For correct operation, the board must be connected to the earthing conductor present in the system. Install, upstream of the system, a differential thermal breaker.**

4.7. J3, J5 RAPID CONNECTORS - FOR OPENING AND CLOSING LIMIT-SWITCHES (FIG. 2)

Quick-fit connector for connection of the opening (J3) and closing (J5) limit-switches.

4.8. J6 CONNECTOR - BEAM BREAKING SENSOR (FIG. 2)

Quick-fit connector for connecting the beam breaking sensor (where present). If this sensor is absent, leave the supplied jumper in place.

4.9. DS1 FREQUENCY SELECTOR (FIG. 1)

DIP-SWITCH selector used to set a HIGH or LOW working frequency of the vehicle loop detectors. Consult chapter 5.5.

4.10. J4 CONNECTOR - FOR MINIDEC, DECODER AND RP

It is used for rapid connection of Minidec, Decoder and RP/ RP2 Receivers.

If you are using an RP2 twin-channel receiver, you will be able to directly command the automated system's OPEN and CLOSE from a twin-channel radio control.

If using a single-channel RP type receiver, only OPEN can be commanded.

Fit the accessory with the component side directed toward the board interior.

⚠ **Insert and remove the boards ONLY after cutting power.**

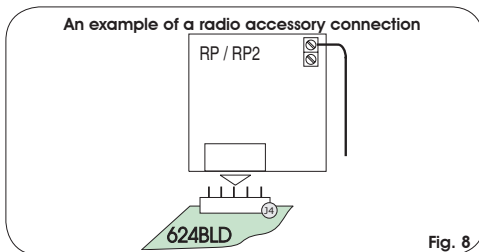

5. PROGRAMMING

To programme the operation of the automated system, the "PROGRAMMING" mode must be accessed.

Programming is in three parts: 1st LEVEL, 2nd LEVEL and 3rd LEVEL.

👉 **modification of the programming parameters is immediately effective, whereas definitive memory-storage occurs only on exiting programming and returning to the view of the automated system status. If you cut power to the unit before returning to view the status, all the modifications made will be lost.**

👉 **You can return to viewing the status from any point of programming at any level, by pressing keys F and - simultaneously.**

5.1. 1ST LEVEL PROGRAMMING

To access 1st LEVEL PROGRAMMING, use push-button F:

- if you press it (and hold it down), the display shows the name of the first function.
- if you release the push-button, the display shows the value of the function, which can be changed with keys + and -.

- if you press **F** again (and hold it down), the display shows the name of the next function, etc.
- when you reach the last function, press the push-button **F** to exit programming, and the display resumes showing the inputs status.

1ST LEVEL PROGRAMMING		
Display	Function	Default
dF	<p>LOADING PARAMETERS:</p> <p>00 Neutral condition 01 Default FAAC 1 loaded 02 Default RESERVED FOR FAAC 03 Default FAAC CITY loaded 04 Default FAAC CITY K loaded 05 Default J275 loaded 06 Default J275K loaded</p> <p>LEAVE AT 00 IF YOU DO NOT WISH TO MAKE ANY CHANGE TO THE PROGRAMMING. For an explanation of the dF parameter refer to page 8 chapter 5.2.</p>	00
bu	<p>BUS ACCESSORY MENU</p> <p>For an explanation of this parameter refer to page 8 chapter 5.3.</p>	≡
LO	<p>FUNCTION LOGICS:</p> <p>A Automatic A1 Automatic 1 E Semiautomatic P Parking PA Parking automatic Cn Condo CA Condo automatic rb Faac-City (traffic bollard logic) C Dead-man r Remote CU Custom</p>	E
PA	<p>PAUSE TIME:</p> <p>This operates only if an automatic logic was selected. Can be adjusted from 0 to 59 sec. in 1 second steps. Subsequently, the display changes to show minutes and tenths of a second (separated by a dot) and time is adjusted in 10 second steps, up to the maximum value of 4.1 minutes. e.g. if the display shows 2.5, the pause time will be 2 min and 50 sec.</p>	20
FO	<p>POWER:</p> <p>Adjusts motor power. 01 = minimum power 50 = maximum power</p>	50
LI	<p>LOOP 1:</p> <p>If this function is enabled, the loop connected to the Loop1 input will have the OPEN function. Y = loop1 active nO = loop1 not active</p> <p>Attention: if the function is not enabled, loop1 status will nevertheless be available on one of the outputs, if appropriately set (see second level programming).</p>	nO

Display	Function	Default
L2	<p>LOOP 2:</p> <p>If this function is enabled, the loop connected to Loop2 input will have the SAFETY/CLOSE function, i.e. it will operate as SAFETY during the closing stage, and will command CLOSE to the board at release. Y = loop2 active nO = loop2 not active</p> <p>Attention: if the function is not enabled, loop2 status will nevertheless be available on one of the outputs, if appropriately set.</p>	nO
H1	<p>BOOST LOOP 1 FUNCTION</p> <p>Y = Active nO = Not active</p> <p>Thanks to this function you can increase the sensitivity level at the moment of detection. When the vehicle leaves the loop, the sensitivity returns to the selected level. This system holds the detection contact even in the event of very high vehicles as well as during the passage of a tractor with trailer.</p>	nO
H2	<p>BOOST LOOP 2 FUNCTION</p> <p>Y = Active nO = Not active See BOOST LOOP1 function.</p>	nO
S1	<p>SENSITIVITY LOOP 1</p> <p>Regulates the sensitivity of the loop: 01 = minimum 10 = maximum</p>	05
S2	<p>SENSITIVITY LOOP 2</p> <p>Regulates the sensitivity of the loop: 01 = minimum 10 = maximum</p>	05
St	<p>AUTOMATED SYSTEM STATUS:</p> <p>Exit programming, memory storage of data set and return to automated system status view.</p> <p>00 Closed 01 Opening pre-flashing 02 Opening 03 Open 04 In pause 05 Closing pre-flashing 06 Closing 07 Stopped ready to close 08 Stopped ready to open 09 Emergency opening 10 Closing safety device in operation</p>	



The display of the automated system status **St** is of fundamental importance for the operator assigned to installation/maintenance, to distinguish the logical processes the board performs during movements. If, for example, the automated system is in CLOSED state 00 must be shown on the display. On reaching the command OPEN, the display will change to 01, if pre-flashing is enabled, or directly to 02 (the OPENING movement), to then display 03 on reaching the OPEN position.

Example of sequence of states displayed starting from barrier closed:

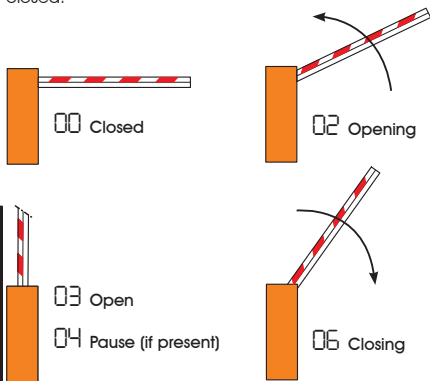

In the sequence, states 01 and 05 are not shown; these correspond to pre-flashing at opening and at closing, respectively.

5.2. MODIFICATION OF THE PRE-SETTING

The modification of the dF parameter enables you to automatically load 6 different configurations modifying all programming values at every level with preset values. This possibility is a convenient starting point for subsequent rapid 'fine tuning' of the 624 BLD for functioning with 6 different types of installation.

6 PRE-SETTINGS may be selected:

- 01 Default FAAC for barriers
- 02 Default RESERVED FOR FAAC
- 03 Default for the FAAC CITY 275 H600 and H800 range
- 04 Default for FAAC CITY 275 H700 K
- 05 Default for J275
- 06 Default for J275K

To implement loading of the values of one of the 6 pre-settings, select the required pre-setting (01, 02, 03, 04, 05, 06) and exit 1st level programming.

EXAMPLE: selecting 01 and exiting 1st level programming, all the FAAC default values which can be found in the 1st, 2nd and 3rd level tables in the "Default" column are loaded. The 624 BLD is therefore configured for movement of a barrier.



THE LOADING OF A PRE-SETTING CANCELS ALL THE MODIFICATIONS PREVIOUSLY MADE AT ANY PROGRAMMING STEP. IF YOU DO NOT WISH TO LOAD ANY PRE-SETTING, LEAVE THE dF STEP AT 00



The dF, step, unlike the others, does not store the value selected but returns to show 00 again, as standard condition.

It is therefore not possible to identify what pre-setting was previously set.

If you do not wish to load any pre-setting, ALWAYS leave the dF step at value 00 and move on to the following programming step.

Ensure that you load the desired default and exit 1st level programming BEFORE modifying other steps, in order to avoid deleting all the modifications made.

To learn more about the specifications of each pre-setting, refer to chapter 10 on page 15.

5.3. SETUP and BUS SYSTEM CONTROL

Each time you install one or more BUS accessories (as explained in chapter 4.3) these must be stored on the board.

Storage is performed as follows:

- enter the first programming level as explained in chapter. 5.1;
- at the BU programming step, release programming push-button F and press push-button + for 1 second.

The display shows -- for an instant and then returns to the standard condition indicated in fig. 10. The storage procedure is finished.

The BU programming step also has the function of displaying the status of the BUS technology accessories. Figure 9 indicates the exact correspondence between the segments of the display and the inputs.

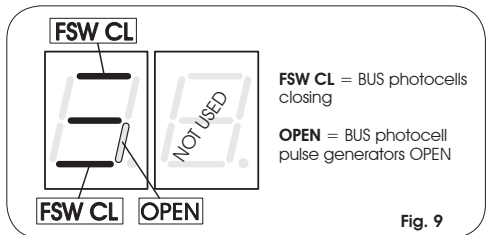

Fig. 9

Segment ON = closed contact
Segment OFF = open contact

The configuration for correct operation of the automated system should show the three horizontal segments ON as in figure 10.



Fig. 10

In case of engagement of the closure photocells, the upper and lower segments switch off, leaving the central segment on, as in figure 11.



Fig. 11

In case of engagement of the PULSE GENERATOR OPEN pair, the corresponding vertical segment switches on for the engagement time of the pair, as illustrated in figure 12.



Fig. 12

The PULSE GENERATOR OPEN pair of photocells, if engaged, commands opening of the application and prevents its closure until it is released.



If no pair of BUS photocells is present on the system, the BU programming step will still show the display in figure 10.

The BUS communication system uses a self-diagnostic function able to supply reports of incorrect connection or of erroneous configuration of the BUS accessories.

The display shows the CC signal FLASHING when a SHORT-CIRCUIT is present along the BUS line, as in figure 13. Check the connections made (chapter.4.3).



Fig. 13

The display shows the Er message FLASHING, as in figure 14, if more than one pair of photocells should have the same address.





Fig. 14

In this latter case, check all the addresses set on all the photocells installed, referring to chapter 4.3.

5.4. 2nd LEVEL PROGRAMMING

To access 2nd LEVEL PROGRAMMING, press push-button **F** and, while holding it down, press push-button **+** :

- if you release the **+** push-button, the display shows the name of the first function.
- if you also release the **F** push-button, the display shows the value of the function, which can be changed with keys **+** and **-**.
- if you press the **F** key (and hold it down), the display shows the name of the next function; if you release it, the value is shown and can be modified with keys **+** and **-**.
- when you reach the last function, press push-button **F** to exit programming, and the display resumes showing the inputs status.

2ND LEVEL PROGRAMMING  		
Display	Function	De- fault
bo	MAXIMUM THRUST TORQUE: the motor runs at maximum torque (ignoring torque regulation) at the initial moment of movement. y = Active no = Excluded	y
PF	PRE-FLASHING: it permits activation of the flashing lamp for 5 secs before the start of movement. no excluded OC before each movement PA at end of pause only CL before closing	no
SC	SLOW CLOSING: for setting the entire closing stage at slow speed. y = Active no = Excluded	no
tr	DECELERATION TIME AFTER LIMIT SWITCHES: for setting the deceleration time (in seconds) after the opening and closing limit switches have operated. Can be adjusted from 0 to 10 sec. in 1 second steps. 00 = deceleration excluded 10 = maximum deceleration	03
t	WORK TIME (time-out): A value should be set from 5 to 10 seconds longer than the time required for the automated system to move from the closed position to the open position, and vice-versa. Can be adjusted from 0 to 59 sec. in 1 second steps. Subsequently, the display changes to show minutes and tenths of a second (separated by a dot) and time is adjusted in 10 second steps, up to the maximum value of 41 minutes.	20
FS	FAIL SAFE: If this function is activated, it enables a function test of the photocells before any automated system movement, independently of the output used. If the test fails, the automated system does not start the movement. y = Active no = Excluded	no

o 1	OUTPUT 1: The output can be set to one of the following functions: 00 FAILSAFE 01 INDICATOR LIGHT (lighted at opening and pause, flashing at closing and off when automated system closed). 02 BEAM LIGHTING (output active with beam closed and on pause, inactive with beam open, flashing during movement) 03 beam CLOSED 04 beam OPEN or in PAUSE, it goes off during closing pre-flashing. 05 beam MOVING AT OPENING, pre-flashing included. 06 beam MOVING AT CLOSING, pre-flashing included. 07 beam STILL 08 beam in EMERGENCY status 09 LOOP1 engaged 10 LOOP2 engaged 11 OPEN for 624 SLAVE 12 CLOSE for 624 SLAVE 13 beam DETACHED 14 bollard lights 15 bollard buzzer 16 FCA engaged 17 FCC engaged 18 interlock	00
P1	OUTPUT 1 POLARITY: For configuring the output polarity status. y = N.C. polarity no = N.O. polarity Note: if the output is set to FAIL-SAFE (00) leave the default value no .	no
o 2	OUTPUT 2: See output 1	03
P2	OUTPUT 2 POLARITY: See output 1 polarity	no
o 3	OUTPUT 3: See output 1	01
P3	OUTPUT 3 POLARITY: See output 1 polarity	no
o 4	OUTPUT 4 / BUS: If set at 00 the output is dedicated to accessories with BUS technology. Refer to chapter 4.3 on page 5 for an explanation. This output retains the possibility of configuration of output 1 with the exception of functions 11, 12 which in this case have no effect.	00
P4	OUTPUT 4 POLARITY: For configuring the output polarity status. y = N.C. polarity no = = N.O. polarity (for BUS)	no

AS	<p>ASSISTANCE REQUEST (coupled to the next two functions): If activated at the end of the count-down (settable with the next two functions under "Cycle programming"), it activates LAMP output for 4 sec every 30 sec. (assistance request). Can be useful for setting scheduled maintenance.</p> <p>4 = Active no = Excluded</p>	no
nc	<p>CYCLE PROGRAMMING IN THOUSANDS: For setting a count-down of the system operating cycles, settable value from 0 to 99 (thousands of cycles). The displayed value is reset as the cycles progress, interacting with the nL value (99 nL decrementing steps correspond to one nL decrement). The function can be used combined with nC, to check the use of the system and to make use of the "Assistance request".</p>	00
nC	<p>CYCLE PROGRAMMING IN HUNDREDS OF THOUSANDS: For setting a count-down of the system operating cycles, settable value from 0 to 99 (hundreds of thousands of cycles). The displayed value is reset as the cycles progress, interacting with the nC. (1 nC decrement corresponds to 99 nL decrementing steps). The function can be used combined with nC, to check the use of the system and to make use of the "Assistance request".</p>	01
h1	<p>HOLD TIME LOOP 1 For setting the presence time on loop 1. At the end of this time the board calibrates itself and indicates "loop free" (decimal point of the units OFF). On switching on the board, an automatic reset is performed.</p> <p>4 = 5 minutes no = infinite</p>	no
h2	<p>HOLD TIME LOOP 2 For setting the presence time on loop 2. At the end of this time, the board calibrates itself and indicates "loop free" (decimal point of the tens OFF). On switching on the board, an automatic reset is performed.</p> <p>4 = 5 minutes no = infinite</p>	no
St	<p>AUTOMATED SYSTEM STATUS: Exit programming, memory storage of data and return to gate status display (see paragraph 5.1.).</p>	

Connection:

Connect the loop detectors as indicated in figure 2 on page 4:

- Terminals 1 - 2 for LOOP 1 = loop with opening function;
- Terminals 3 - 4 for LOOP 2 = loop with closing and/or closing safety function.

To learn more about the effect of signals originating from the loops on the automated system, please refer to the logic tables in chapter 12.

To enable the function of the connected loops, enter the 1st programming level and set steps L1 and L2 in 4. To enable the function of the connected loops, enter the 1st programming level and set steps.

The operating status of the loop detector is shown through the use of decimal points on the display when automated system status is displayed (step 5c.).

CALIBRATION

Each time the 624 BLD board is powered, the display shows the automated system status and the integrated loop detector calibrates the connected loops. Therefore, perform a calibration, removing power from the 624 BLD for at least 5 seconds.

Calibration is shown on the display through flashing of the two points, as in figure 15.



Fig. 15



If one or both the magnetic loops are not installed, the loop detector is continually calibrated without this creating problems to the functioning of the board. Therefore, during display of the automated system status, one or both the decimal points will flash constantly.

Once calibration has taken place, the decimal points indicate the loop status:



- Point ON = Loop ENGAGED
- Point OFF = Loop DISENGAGED
- Point FLASHING = Loop NOT CONNECTED or BEING CALIBRATED

REGULATION OF SENSITIVITY

Regulating the sensitivity determines the variation of the inductivity, for each channel, which a vehicle must cause to activate the relative output of the detector.

Regulation of sensitivity is performed separately for each channel with the aid of the two 51 and 52 parameters at the 1st programming level. You can also activate the BOOST function for both detectors. Consult chapter 5.1.

REGULATION OF HOLD TIME

The retaining time count starts on engagement of the loop. If, on expiry of this time, the loop is still engaged, a new calibration is performed automatically where the presence of the metallic mass on the loop no longer causes its engagement. At the end of the new calibration, the loop is considered "disengaged".

The retaining time can be regulated with the aid of the two h1 and h2 parameters at the 2nd programming level.

5.5. SETUP FOR INTEGRATED LOOP DETECTOR

The 624 BLD is equipped with an integrated metallic mass detector for induction detection of vehicles.

Features:

- galvanic separation between the electronics of the detector and of the loop
- automatic alignment of the system immediately after activation
- continual resetting of frequency drifts
- sensitivity independent of loop inductivity
- regulation of the working frequency of the loops
- message of loop engaged with LED display
- loop status addressable on the OUT 1, OUT 2, OUT 3 and OUT 4 outputs

FREQUENCY REGULATION and NEW BALANCING

The working frequency of each of the detector channels can be regulated at two levels with the aid of the DS1 DIP- switch (see fig.1).



- DIP 1 ON = Loop 1 frequency LOW
OFF = Loop 1 frequency HIGH
- DIP 2 ON = Loop 2 frequency LOW
OFF = Loop 2 frequency HIGH

On changing one of these DIPs, it is recommended that a new calibration be performed. In case of installation of two loops, select different frequencies for each loop.

NOTES FOR CONSTRUCTION OF THE LOOPS

The loop must be located at least 15 cm. from fixed metal objects, at least 50 cm. from moving metal objects and not more than 5 cm. from the road surface.

Use a normal single-core cable with a section of 1,5 mm² (if the cable is buried directly, it must be double insulated). Construct a loop, preferably square or rectangular, preparing a PVC cable duct or making a track in the flooring as indicated in figure 16 (the angles must be cut at 45° to avoid cable breakage). Place the cable, performing the number of windings indicated in the table. The two ends of the cable must be intertwined (at least 20 times per metre) from the loop to the detector. Avoid any cable splicing (if it should be necessary, solder the wires and seal the junction with a thermo-shrinking

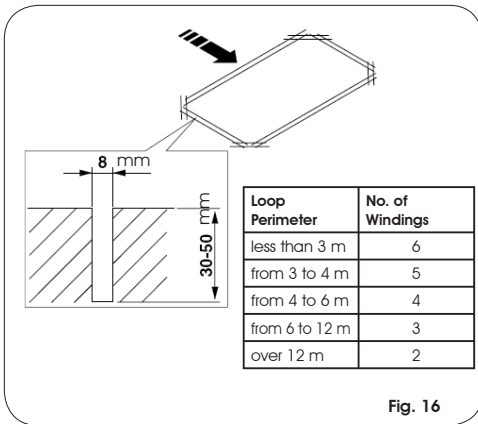

Fig. 16

6. START-UP

6.1. BOARD LEDS CHECK

sheath) and keep it separate from power supply lines. Before the definitive start-up of the 624 BLD unit, control the activation status of the LEDs present.

These LEDs indicate the status of the board inputs and have particular importance for the handling of the automated system:

LED ON : CLOSED contact

LED OFF : OPEN contact

- EMERG - DL5
- STOP - DL4
- FSW - DL3
- CLOSE - DL2
- OPEN - DL1
- PIVOT - DL8
- FCA - DL6
- FCC - DL7

Fig. 16

Figure 16 shows the configuration of the standard LEDs with the automated system CLOSED ready to open.

The Emergency inputs (DL5), STOP (DL4), Photocells (DL3) and Pivot (DL8) are safety inputs with N.C. (normally closed) contacts, therefore the corresponding LEDs are ON.

The FCA and FCC LEDs are the N.C contacts of the limit switches which, if engaged, become open, consequently switching off the corresponding LED:

With Automated system CLOSED	FCA - DL6	FCC - DL7	FCC ENGAGED
With Automated system OPEN	FCA - DL6	FCC - DL7	FCA ENGAGED

6.2. CHECK ON BUS STATUS

Consult this paragraph if BUS photocells have been installed, as indicated in paragraph 4.3 on page 5.

Enter 1st programming level and show the bus programming step on the display.

This step must show three horizontal lines, confirming that all pairs of BUS photocells are not engaged.

Refer to paragraph 5.3 on page 8 for further details on displaying these devices.



7. AUTOMATED SYSTEM TEST

When you have finished programming, check if the system is operating correctly.

Check in particular if power of the automated system is adequately adjusted and if the safety devices connected to it operate correctly.

8. MASTER-SLAVE CONFIGURATIONS

If installation contemplates the use of two opposing barriers to be activated at the same time on opening/ closing, one of the connection diagrams shown below should be used, depending on the control boards used to move the barriers.

By MASTER equipment is meant the control board to which all the pulse generators and safety devices are connected.
By SLAVE equipment is meant the control board which is controlled by the MASTER through pulse inputs, while the safety inputs are short-circuited.

ENGLISH

624BLD MASTER

624BLD SLAVE

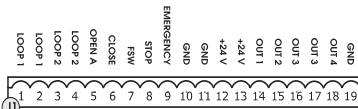
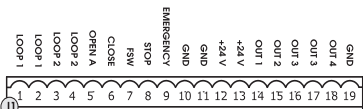

3rd LEVEL PROGRAMMING

03 = 4

OUT2:
o2 = 11 P2 = no

OUT3:
o3 = 12 P3 = no

Logica
Logic
Logique
Nur Logik

Lógica
De logica

per il resto lasciare il default
for the rest leave the default
pour le reste laisser par défaut
programmeren die anderen
werkinstellingen lassen
por lo demas dejar el default
voor de rest default laten

624 BLD MASTER

624 MPS SLAVE

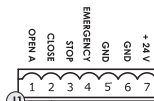
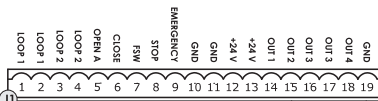

OUT 1:
o1 = 11 P1 = 4

OUT 2:
o2 = 12 P2 = 4

Logica
Logic
Logique
Nur Logik

Lógica
De logica

per il resto lasciare il default
for the rest leave the default
pour le reste laisser par défaut
programmeren die anderen
werkinstellingen lassen
por lo demas dejar el default
voor de rest default laten

624 MPS MASTER

624 BLD SLAVE

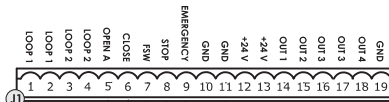
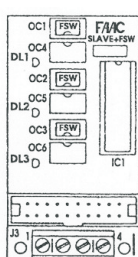
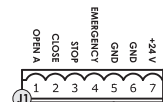

Logica
Logic
Logique
Nur Logik

Lógica
De logica

per il resto lasciare il default
for the rest leave the default
pour le reste laisser par défaut
programmeren die anderen
werkinstellingen lassen
por lo demas dejar el default
voor de rest default laten



Fig. 17

9. 3rd LEVEL PROGRAMMING

The 3rd level programming is only used in the case of advanced customisation of the function logics already present in the memory.

⚠ Before making changes at this level, be sure you fully understand the nature of the steps you wish to modify and their effect on the automated system.

To access 3rd LEVEL PROGRAMMING, **press push-button F and, while holding it down, press push-button + for about 10 seconds.** Use of the **F**, **+** and **-** keys is the same as for the other two programming levels.

3rd LEVEL PROGRAMMING   10 secs		
D.	Function	Setting
01	If you enable this function, automatic closure occurs after pause time.	Y = automatic closure no = disables
02	If you enable this function, operation is with two different inputs : OPEN for opening and CLOSE for closing.	Y = operation on two inputs no = disables
03	Activation of recognition of the levels of the OPEN and CLOSE inputs (command maintained) . That is to say, the board recognises the level (for example, with OPEN maintained and STOP pressed, on release of the latter the automated system continues to open). If 03 is disabled, the board commands a manoeuvre only if the input is varied.	Y = recognition of level no = recognition of the change in status
04	Activation of DEAD MAN opening (command kept pressed). If the OPEN command is released, operation is stopped.	Y = enables no = disables
05	If you enable this function, an OPEN command during opening stops the movement. If parameter 05 is no the system is ready for opening. If parameter 06 is Y the system is ready for closing.	Y = at opening stops movement no = disables
06	If you enable this function, an OPEN command during opening reverses movement. If parameters 05 and 06 are no OPEN has no effect during opening.	Y = at opening reverses no = disables
07	If you enable this function, an OPEN command during the pause stops operation. If parameters 07 and 08 are no OPEN recharges pause time.	Y = in pause stops movement no = disables
08	If you enable this function, an OPEN command during the pause causes closure. If parameters 07 and 08 are no !OPEN recharges pause time.	Y = in pause closes no = disables
09	If you enable this function, an OPEN command during closure, stops operation, otherwise it reverses movement.	Y = stops no = reverses
10	DEAD MAN closing enabled (command kept pressed). If you release the CLOSE command , operation is stopped.	Y = enables no = disables
11	If you enable this function, a CLOSE command has priority over OPEN, otherwise OPEN has priority over CLOSE.	Y = enables no = disables
12	If you enable this function, a CLOSE command commands closure when it is released. Until CLOSE is enabled, the unit remains in closure pre-flashing.	Y = closes when released no = closes at once
13	If you enable this function, a CLOSE command during opening stops operation, otherwise the CLOSE command commands reversing immediately or at end of opening (also see parameter 14)	Y = CLOSE stops movement no = CLOSE reverses
14	If you enable this function, and if parameter 13 is no, the CLOSE command commands immediate closure at end of opening cycle (memory stores CLOSE). If parameters 13 and 14 are no CLOSE commands immediate closure.	Y = closes at the end of opening no = immediate closure
15	If you enable this function, when the system is stopped by a STOP, a subsequent OPEN command moves in the opposite direction. If parameter 15 is no † always closes.	Y = moves in the opposite direction no = always closes
16	If you enable this function, during closing, the CLOSING SAFETY DEVICES stop movement and allow resumption of movement when disengaged, otherwise they immediately reverse at opening.	Y = closes at disengagement no = immediate reversing
17	If you enable this function, the CLOSING SAFETY DEVICES command closure when disengaged (also see parameter 18).	Y = closure when FSW disengaged no = disables
18	If you enable this function, and if parameter 17 is Y, the unit waits for the opening cycle to end before executing the closing command supplied by the CLOSING SAFETY DEVICES .	Y = closes at the end of opening no = disables
19	If you enable this function, during closing, LOOP2 stops movement and allows it to resume at disengagement, otherwise it immediately reverses at opening.	Y = closure at disengagement no = immediate reversing
20	If you enable this function, LOOP2 commands closing when it disengages (also see parameter 21).	Y = closes if LOOP2 is free no = disables
21	If you enable this function, and if parameter 20 is Y, the unit waits for the opening cycle to end before executing the closing command supplied by LOOP2 .	Y = closes at the end of opening no = disables
22	If you enable this function, LOOP1 commands have priority over LOOP2 commands.	Y = enables no = disables

D.	Function	Setting
23	LOOP 1 commands opening and, at end of opening, closes if released (useful if a vehicle reverses with consecutive loops). If disabled at disengagement of LOOP 1, no closure is performed.	Y = closes if LOOP1 is free no = disables
24	NOT USED	/
25	A.D.M.A.P function If you enable this function, the safety devices operate according to French standards.	Y = enables no = disables
26	If you enable this function, during closure, the CLOSING SAFETY DEVICES stop movement and, when disengaged, reverse movement, otherwise they reverse immediately.	Y = stops movement and reverses when disengaged. no = reverses immediately.
27	NO EFFECT	/
A1	PRELAMPEGGIO: Used for adjusting - in 1 sec steps - the duration of required pre-flashing, from a minimum of 0 to a maximum of 10 seconds	05
A2	TIMEOUT FOR REVERSING AT CLOSURE: If you enable this function, during closing, you can decide whether to reverse or stop the movement when time out elapses (closing stroke limit not reached).	Y = reversal no = block
A3	OPENING AT POWER UP: In case of a power cut, when power is restored, an opening operation can be commanded by enabling this function (only if the automated system is not closed, FCC free).	Y = opening no = stays idle
A4	TIME FOR ENABLING FAAC CITY PRESSURE SWITCH (J5): This is the time after which the unit considers the signal originating from the pressure switch as the CLOSING TRAVEL-LIMIT. Can be adjusted from 0 to 59 sec. in 1 second steps. Subsequently, the display changes to show minutes and tenths of a second (separated by a dot), up to a maximum value of 4.1 minutes.	4.0
A5	DISABLING OF BOLLARD PRESSURE SWITCH AT START OF MOVEMENT: For a correct operation of the bollard, you have to disable the pressure switch check at start of the upstroke movement (time: 0.4 seconds). Set this function to Y with bollards.	Y = pressure switch not active at thrust no = pressure switch always active
A6	BOLLARD SOLENOID VALVE POWER SUPPLY CHECK (terminals 22-23): FAAC CITY K - J275K: solenoid valve output usually not supplied with power – supplied with power during downstroke. FAAC CITY - J275 standard: standard: solenoid valve output usually supplied with power – not supplied with power during downstroke.	Y = for FAAC CITY K /J275K no = for FAAC CITY standard and J275
A7	POLARITY OF OPENING TRAVEL-LIMIT STOP: Configuration of the travel-limit stop contact	Y = NO polarity no = NC polarity
A8	POLARITY OF CLOSING TRAVEL-LIMIT STOP: Configuration of the travel-limit stop contact	Y = NO polarity no = NC polarity
A9	FAAC CITY PRESSURE SWITCH ENABLE (J5): Detection of the PRESSURE SWITCH contact as safety device during the first upstroke phase and as limit switch after activation time of FAAC CITY pressure switch (parameter A4).	Y = Operation for FAAC CITY no = Standard limit switch operation
B0	SAFETY ONLY PRESSURE SWITCH FOR BOLLARDS (terminals 7 - GND): Recognition of PHOTOCELL contact as a safety PRESSURE SWITCH. (The contact is ignored at start of movement and at the end of the upstroke)	Y = Operation of safety only pressure switch no = Operation of standard photocells
B1	HOLD CLOSE / HOLD OPEN FUNCTION DELAY: Delay of the activation of the HOLD CLOSE / HOLD OPEN function (see parameters b3 and b4). The count starts when the involved limit switch has been reached. If, at the end of the set time, the limit switch is involuntarily disengaged, the HOLD CLOSE / HOLD OPEN function is activated. 00 = HOLD CLOSE / HOLD OPEN function activated immediately 01 to 99 = minutes of count before activation of HOLD CLOSE / HOLD OPEN	30
B2	DO NOT MODIFY	30
B3	HOLD OPEN FUNCTION: If the opening limit switch is involuntarily disengaged, the board commands automatically a movement for 2 sec. to restore the position; if the opening limit switch is not engaged during this period of time, the automated system is activated max. for the operating time "t" see 2nd PROGRAMMING LEVEL: (parameter A3 recommended on Y if parameter b3 set on Y)	Y = enables no = disables
B4	HOLD CLOSE FUNCTION: If the closing limit switch is involuntarily disengaged, the board commands automatically a movement for 2 sec. to restore the position; if the closing limit switch is not engaged during this period of time, the automated system is activated max. for the operating time "t" see 2nd PROGRAMMING LEVEL:	Y = enables no = disables

D.	Function	Setting
65	CONTROL OF BOLLARDS SOLENOID VALVE: Function to be set to 3 for J275 / J275K Function to be set to no for FAAC CITY / FAAC CITY K.	3 = for J275 / J275K no = FAAC CITY / FAAC CITY K
66	EMERGENCY INPUT OPERATING LOGIC: If you activate this function, the emergency input commands a closure, which is kept until the contact is restored. If the function is not active, the emergency input commands an opening, which is kept until the contact is restored.	3 = active no = not active
5t	AUTOMATED SYSTEM STATUS: Exit programming, memory storage of data and return to gate status display (see par. 5.1.).	

9.1. CUSTOMISATION OF FUNCTION LOGIC

The 3rd programming level values vary depending on the logic selected at the first programming level.

The 3rd programming level is dedicated to customisation of one of the logics selectable if non-standard behaviour of application should be needed.

Procedure for implementing the modification of one or more 3rd programming level parameters which customise the function of the logic set:

1. Select one of the basic logics most suitable for your requirements.
2. Enter the 3rd programming level and modify the required parameters.
3. Exit the 3rd programming level and select logic C U.

The C U logic activates the modifications made at the 3rd level.

The following table contains the default parameters affecting the function logics.

Step	A	A1	E	P	PA	Cn	CA	rb	C
01	Y	Y	N	N	Y	N	Y	Y	N
02	N	N	N	Y	Y	Y	Y	Y	Y
03	N	N	N	N	N	N	N	Y	N
04	N	N	N	N	N	N	N	N	Y
05	N	N	Y	N	N	N	N	N	N
06	N	N	Y	N	N	N	N	N	N
07	N	N	N	N	N	N	N	N	N
08	N	N	N	N	N	N	N	N	N
09	N	N	N	N	N	N	N	N	N
10	N	N	N	N	N	N	N	N	Y
11	N	N	N	N	N	N	N	N	N
12	N	N	N	Y	Y	N	N	N	N
13	N	N	N	N	N	N	N	N	N
14	N	N	N	Y	Y	Y	Y	N	N
15	N	N	N	N	N	N	N	N	N
16	N	N	N	Y	Y	N	N	N	N
17	N	Y	N	N	N	N	N	N	N
18	N	Y	N	N	N	N	N	N	N
19	N	N	N	Y	Y	N	N	N	N
20	N	Y	N	Y	Y	Y	Y	N	N
21	N	Y	N	Y	Y	Y	Y	N	N
22	N	N	N	N	N	Y	Y	N	N
23	N	N	N	Y	Y	N	N	N	N
24	N	N	N	N	N	N	N	N	N
25	N	N	N	N	N	N	N	N	N
26	N	N	N	N	N	N	N	N	N

10. PRE-SETTING VALUES

The table below shows the values of the steps at each programming level in relation to the pre-setting chosen

1st LEVEL	Default FAAC1	RESERVED FOR FAAC	Default FAAC CITY	Default FAAC CITY K	Default J275	Default J275K
	dF pre-setting	01	02	03	04	05
bu BUS	—	—	—	—	—	—
Lo logic	E	R1	rb	rb	rb	rb
PR pause	20	20	30	30	30	30
FO power	50	50	50	50	50	50
L 1 loop 1	no	no	no	no	no	no
L2 loop 2	no	no	no	no	no	no
H 1 loop 1	no	no	no	no	no	no
H 2 loop 2	no	no	no	no	no	no
S 1 sensitivity	05	05	05	05	05	05
S2 sensitivity	05	05	05	05	05	05

2nd LEVEL	Default FAAC1	RESERVED FOR FAAC	Default FAAC CITY	Default FAAC CITY K	Default J275	Default J275K
	bo boost	4	4	4	4	4
PF pre-flashing	no	CL	no	no	no	no
SC slow closing	no	no	no	no	no	no
tr slow-down	03	03	01	01	01	01
t time out	20	20	12	12	12	12
FS fail safe	no	no	no	no	no	no
o 1 output 1	00	16	15	15	15	15
P 1 polarity 1	no	no	no	no	no	no
o2 output 2	03	17	14	14	03	03
P2 polarity 2	no	no	no	no	no	no
o3 output 3	01	01	01	01	02	02
P3 polarity 3	no	no	no	no	no	no
o4 output 4	00	00	00	00	00	00
P4 polarity 4	no	no	no	no	no	no
RS assistance	no	no	no	no	no	no
nc cycles 1.	00	00	00	00	00	00
nc cycles 2.	01	01	01	01	01	01
h 1 hold	no	no	no	no	no	no
h2 hold	no	no	no	no	no	no

3rd LEVEL

	Default FAAC1	RESERVED FOR FAAC	Default FAAC CITY	Default FAAC CITY K	Default J275	Default J275K
01	no	y	y	y	y	y
02	no	no	y	y	y	y
03	no	no	y	y	y	y
04	no	no	no	no	no	no
05	y	no	no	no	no	no
06	y	no	no	no	no	no
07	no	no	no	no	no	no
08	no	no	no	no	no	no
09	no	no	no	no	no	no
10	no	no	no	no	no	no
11	no	no	no	no	no	no
12	no	no	no	no	no	no
13	no	no	no	no	no	no
14	no	no	no	no	no	no
15	no	no	no	no	no	no
16	no	no	no	no	no	no
17	no	y	no	no	no	no
18	no	y	no	no	no	no
19	no	no	no	no	no	no
20	no	y	no	no	no	no
21	no	y	no	no	no	no
22	no	no	no	no	no	no
23	no	no	no	no	no	no
24	no	no	no	no	no	no
25	no	no	no	no	no	no
26	no	no	no	no	no	no
27	no	no	no	no	no	no
A1	05	01	05	05	05	05
A2	no	no	no	no	no	no
A3	no	no	no	no	no	no
A4	4.0	4.0	04	04	4.0	4.0
A5	no	no	y	y	y	y
A6	no	no	no	y	no	y
A7	no	no	y	y	no	no
A8	no	no	no	y	no	no
A9	no	no	y	y	no	no
b0	no	no	no	no	y	y
b1	00	00	30	30	30	30
b2	30	30	30	30	30	30
b3	no	no	y	y	y	y
b4	no	no	no	no	no	no
b5	no	no	no	no	y	y
b6	no	no	no	no	no	no

ENGLISH

11. NOTES

12. INTERLOCK CONNECTION

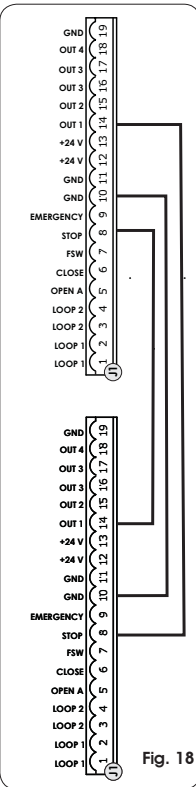
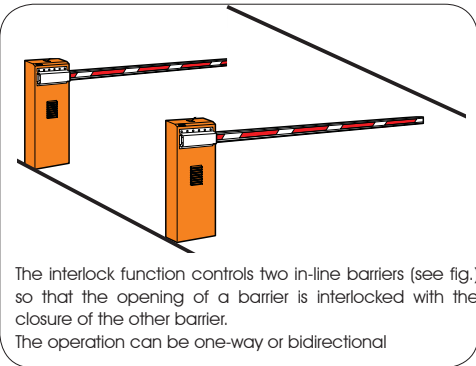

For in-line barriers, enable OUT1 INTERLOCK on parameter 18 (see 2nd PROGRAMMING LEVEL) on both boards and connect them as shown in fig. 18

Fig. 18

13. FUNCTION LOGIC TABLES

Tab. 1/a

LOGIC "A"	PULSES					
AUTOMATED SYSTEM STATUS	OPEN A	CLOSE	STOP	FSW	LOOP 1	LOOP 2
CLOSED	opens and re-closes after pause time	no effect	no effect (opening disabled)	no effect	opens and re-closes after pause time	no effect
OPENING	no effect	reverses immediately at closing	stops operation	no effect	no effect	no effect
OPEN IN PAUSE	recharges pause time	closes	stops operation	recharges pause time (closing disabled)	recharges pause time	recharges pause time (closing disabled)
CLOSING	reverses immediately at opening	no effect	stops operation	reverses immediately at opening	reverses immediately at opening	reverses immediately at opening
STOPPED	closes	closes	no effect (opening and closing disabled)	no effect (closing disabled)	opens and re-closes after pause time	no effect (closing disabled)

ENGLISH

Tab. 1/b

LOGIC "A1"	PULSES					
AUTOMATED SYSTEM STATUS	OPEN A	CLOSE	STOP	FSW	LOOP 1	LOOP 2
CLOSED	opens and re-closes after pause time	no effect	no effect (opening disabled)	no effect	opens and re-closes after pause time	no effect
OPENING	no effect	reverses immediately at closing	stops operation	closes immediately at end of opening	no effect	closes immediately at end of opening
OPEN IN PAUSE	recharges pause time	closes	stops operation	closes	recharges pause time	closes
CLOSING	reverses immediately at opening	no effect	stops operation	reverses immediately at opening	reverses immediately at opening, closes at pause end	reverses immediately at opening, re-closes when opening finished
STOPPED	closes	closes	no effect (opening and closing disabled)	no effect (closing disabled)	opens and re-closes after pause time	no effect (closing disabled)

Tab. 1/c

LOGIC "E"	PULSES					
AUTOMATED SYSTEM STATUS	OPEN A	CLOSE	STOP	FSW	LOOP 1	LOOP 2
CLOSED	opens	no effect	no effect (opening disabled)	no effect	opens	no effect
OPENING	stops operation	reverses immediately at closing	stops operation	no effect	no effect	no effect
OPEN	closes	closes	no effect (closing disabled)	no effect (closing disabled)	closes	no effect (closing disabled)
CLOSING	reverses immediately at opening	no effect	stops operation	reverses immediately at opening	reverses immediately at opening	reverses immediately at opening
STOPPED	closes	closes	no effect (opening and closing disabled)	no effect (closing disabled)	opens	no effect (closing disabled)

↷ In brackets the effects on the other active pulse inputs

LOGIC "P"	PULSES					
AUTOMATED SYSTEM STATUS	OPEN A	CLOSE	STOP	FSW	LOOP 1	LOOP 2
CLOSED	opens	no effect	no effect (opening disabled)	no effect	opens and at end of opening closes if disengaged	no effect
OPENING	no effect	closes immediately at end of opening	stops operation	no effect	no effect	closes immediately at end of opening
OPEN	no effect (closing disabled)	closes	no effect (closing disabled)	no effect (closing disabled)	prevents closure	closes
CLOSING	reverses immediately at opening	no effect	stops operation	stops and continues to close on release	reverses immediately at opening and closes at end of opening if disengaged	stops and continues to close on release
STOPPED	opens	closes	no effect (opening and closing disabled)	no effect (closing disabled)	opens and at end of opening closes if disengaged	no effect (closing disabled)

Tab. 1/e

LOGIC "PA"	PULSES					
AUTOMATED SYSTEM STATUS	OPEN A	CLOSE	STOP	FSW	LOOP 1	LOOP 2
CLOSED	opens and re-closes after pause time	no effect	no effect (opening disabled)	no effect	opens and at end of opening closes if disengaged	no effect
OPENING	no effect	closes immediately at end of opening	stops operation	no effect	no effect	closes immediately at end of opening
OPEN IN PAUSE	recharges pause time	closes	stops operation	recharges pause time (closing disabled)	recharges pause time	closes
CLOSING	reverses immediately at opening	no effect	stops operation	stops and continues to close on release	reverses immediately at opening and closes at end of opening if disengaged	stops and continues to close on release
STOPPED	opens and re-closes after pause time	closes	no effect (opening and closing disabled)	no effect (closing disabled)	opens and at end of opening closes if disengaged	no effect (closing disabled)

Tab. 1/f

LOGIC "Cn"	PULSES					
AUTOMATED SYSTEM STATUS	OPEN A	CLOSE	STOP	FSW	LOOP 1	LOOP 2
CLOSED	opens	no effect	no effect (opening disabled)	no effect	opens	no effect
OPENING	no effect	closes immediately at end of opening	stops operation	no effect	no effect	closes immediately at end of opening
OPEN	no effect (closing disabled)	closes	no effect (closing disabled)	no effect (closing disabled)	no effect	closes
CLOSING	reverses immediately at opening	no effect	stops operation	reverses at opening and closes after pause time	reverses immediately at opening	reverses immediately at opening
STOPPED	opens	closes	no effect (opening and closing disabled)	no effect (closing disabled)	opens	no effect (closing disabled)

⇒ In brackets the effects on the other active pulse inputs

Tab. 1/g

LOGIC "CA"	PULSES						
	AUTOMATED SYSTEM STATUS	OPEN A	CLOSE	STOP	FSW	LOOP 1	LOOP 2
CLOSED	opens and re-closes after pause time	no effect	no effect (opening disabled)	no effect	no effect	opens and re-closes after pause time	no effect
OPENING	no effect	closes immediately at end of opening	stops operation	no effect	no effect	no effect	closes immediately at end of opening
OPEN IN PAUSE	recharges pause time	closes	stops operation	recharges pause time (closing disabled)	recharges pause time	closes	
CLOSING	reverses immediately at opening	no effect	stops operation	reverses at opening and closes after pause time	reverses immediately at opening	reverses immediately at opening	
STOPPED	opens and re-closes after pause time	closes	no effect (opening and closing disabled)	no effect (closing disabled)	no effect (closing disabled)	opens and re-closes after pause time	no effect (closing disabled)

ENGLISH

Tab. 1/h

LOGIC "rb"	PULSES						
	AUTOMATED SYSTEM STATUS	OPEN A	CLOSE	STOP	FSW	LOOP 1	LOOP 2
CLOSED	opens and re-closes after pause time	no effect	no effect (opening disabled)	no effect	no effect	opens and re-closes after pause time	no effect
OPENING	no effect	reverses immediately at closing	stops operation	no effect	no effect	no effect	no effect
OPEN IN PAUSE	recharges pause time	closes	stops operation	recharges pause time (closing disabled)	recharges pause time	recharges pause time (closing disabled)	
CLOSING	reverses immediately at opening	no effect	stops operation	reverses immediately at opening	reverses immediately at opening	reverses immediately at opening	
STOPPED	opens and re-closes after pause time	closes	no effect (opening and closing disabled)	no effect (closing disabled)	no effect (closing disabled)	opens and re-closes after pause time	no effect (closing disabled)

Tab. 1/i

LOGIC "C"	MAINTAINED COMMANDS			PULSES			
	AUTOMATED SYSTEM STATUS	OPEN A	CLOSE	STOP	FSW	LOOP 1	LOOP 2
CLOSED	opens	no effect	no effect (opening disabled)	no effect	no effect	no effect	no effect
OPENING	/	no effect	stops operation	no effect	no effect	no effect	no effect
OPEN	no effect (closing disabled)	closes	stops operation	no effect	no effect (closing disabled)	no effect (closing disabled)	no effect (closing disabled)
CLOSING	reverses immediately at opening	/	stops operation	Stops operation	stops operation	stops operation	stops operation
STOPPED	opens	closes	no effect (opening and closing disabled)	no effect (closing disabled)	no effect (closing disabled)	no effect (closing disabled)	no effect (closing disabled)

↷ In brackets the effects on the other active pulse inputs

Le descrizioni e le illustrazioni del presente manuale non sono impegnative. La FAAC si riserva il diritto, lasciando inalterate le caratteristiche essenziali dell'apparecchiatura, di apportare in qualunque momento e senza impegnarsi ad aggiornare la presente pubblicazione, le modifiche che essa ritiene convenienti per miglioramenti tecnici o per qualsiasi altra esigenza di carattere costruttivo o commerciale.

The descriptions and illustrations contained in the present manual are not binding. FAAC reserves the right, whilst leaving the main features of the equipments unaltered, to undertake any modifications it holds necessary for either technical or commercial reasons, at any time and without revising the present publication.

Les descriptions et les illustrations du présent manuel sont fournies à titre indicatif. FAAC se réserve le droit d'apporter à tout moment les modifications qu'elle jugera utiles sur ce produit tout en conservant les caractéristiques essentielles, sans devoir pour autant mettre à jour cette publication.

Die Beschreibungen und Abbildungen in vorliegendem Handbuch sind unverbindlich. FAAC behält sich das Recht vor, ohne die wesentlichen Eigenschaften dieses Gerätes zu verändern und ohne Verbindlichkeiten in Bezug auf die Neufassung der vorliegenden Anleitungen, technisch bzw. konstruktiv/kommerziell bedingte Verbesserungen vorzunehmen.

Las descripciones y las ilustraciones de este manual no comportan compromiso alguno. FAAC se reserva el derecho, dejando inmutadas las características esenciales de los aparatos, de aportar, en cualquier momento y sin comprometerse a poner al día la presente publicación, todas las modificaciones que considere oportunas para el perfeccionamiento técnico o para cualquier otro tipo de exigencia de carácter constructivo o comercial.

De beschrijvingen in deze handleiding zijn niet bindend. FAAC behoudt zich het recht voor op elk willekeurig moment de veranderingen aan te brengen die het bedrijf nuttig acht met het oog op technische verbeteringen of alle mogelijke andere productie- of commerciële eisen, waarbij de fundamentele eigenschappen van de apparaat gehandhaafd blijven, zonder zich daardoor te verplichten deze publicatie bij te werken.



FAAC



732535 - Rev. F