

THE 760 OPERATOR AND 455 D CONTROL PANEL: INSTALLATION MANUAL

July, 2006
760 Operator And
455 D Control Panel
Installation Manual

CONTENTS

Important Safety Information	2	The 455 D Control Panel General Description	20
Technical Data	4	Installing the 455 D Control Panel	20
Unpacking the Operator	5	Connect the Main Power Supply	20
The 760 Operator General Characteristics	6	Connect the Operator(s) to the Control Panel	21
Installation Instructions	6	Check the Motor's Direction of Rotation	21
Prepare the Gate	6	Connect Other Devices	22
Manual Release Mechanism	7	Set Other Operating Controls	24
Installing the Operator	8	Programming	26
Install the Load Bearing Box	8	Learning of Operating Times	28
Secure the Load Bearing Box	8	Learning of Normal Times	28
Install the Gate Leaf Shoe	9	Learning Times with Gatecoder	28
Install the Operator in the Load Bearing Box	10	Automated Systems Test	29
Install the 455 D Control Panel	12	Logic Tables of 455 D Control	30
Adjust the Hydraulic Pressures	13		
Fine tune the Hydraulic Pressures	13	Maintenance	32
Adjust the Beginning of the Braking Phase	13	Safety in Gate Design	33
Adjust the Braking Intensity	14	Troubleshooting	34
Assemble and Install the Manual Release	14	Limited Warranty	36
Installing an Extension Arm	15		
Exploded View of the 760 Operator	16		
760 Parts List	17		
Exploded View of the 760 CBAC Operator	18		
Exploded View of the Load Bearing Box	19		

The 455 D Control Panel Installation Instructions

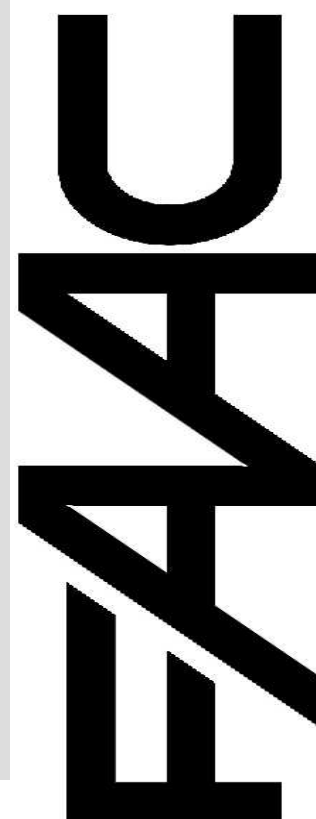

IMPORTANT SAFETY INFORMATION

Both the installer and the owner and/or operator of this system need to read and understand this installation manual and the safety instructions supplied with other components of the gate system. This information should be retained by the owner and/or operator of the gate.

WARNING! To reduce the risk of injury or death

1. **READ AND FOLLOW ALL INSTRUCTIONS.**
2. Never let children operate or play with gate controls. Keep the remote control away from children.
3. Always keep people and objects away from the gate. **NO ONE SHOULD CROSS THE PATH OF THE MOVING GATE.**
4. Test the gate operator monthly. The gate **MUST** reverse on contact with a rigid object or stop when an object activates the non-contact sensors. After adjusting the force or the limit of travel, retest the gate operator. Failure to adjust and retest the gate operator properly can increase the risk of injury or death.
5. Use the emergency release only when the gate is not moving.
6. **KEEP GATES PROPERLY MAINTAINED.** Read the owner's manual. Have a qualified service person make repairs to gate hardware.
7. The entrance is for vehicles only. Pedestrians must use separate entrance.
8. **SAVE THESE INSTRUCTIONS.**

When installing the photo-beams supplied with this unit two things need to be considered.

1. Care should be exercised to reduce the risk of nuisance tripping, such as when a vehicle, trips the sensor while the gate is in motion.
2. One or more photo-beams shall be located where the risk of entrapment exists, such as the perimeter reachable by the moving gate leaf.

GATE DESIGN

1. A gate is a potential traffic hazard, so it is important that you locate the gate far enough away from the road to eliminate the potential of traffic getting backed up. This distance is affected by the size of the gate, how often it is used, and how fast the gate operates.
2. The operator you choose to install on your gate must be designed for the type and size of your gate and for the frequency with which you use the operator.
3. Your gate must be properly installed and must work freely in both directions before the automatic operator is installed.
4. An automatic operator should be installed on the inside of the property/fence line. Do not install the operator on the public side of the property/fence line.
5. Pedestrians should not use a vehicular gate system. Prevent such inappropriate use by installing separate gates for pedestrians.
6. Exposed, reachable pinch points on a gate are potentially hazardous and must be eliminated or guarded.
7. Outward swinging gates with automatic operators should not open into a public area.
8. The operating controls for an automatic gate must be secured to prevent the unauthorized use of those controls.
9. The controls for an automatic gate should be located far enough from the gate so that a user cannot accidentally touch the gate when operating the controls.
10. An automatic gate operator should not be installed on a gate if people can reach or extend their arms or legs through the gate. Such gates should be guarded or screened to prevent such access.

INSTALLATION

1. If you have any question about the safety of the gate operating system, do not install this operator. Consult the operator manufacturer.
2. The condition of the gate structure itself directly affects the reliability and safety of the gate operator.
3. Only qualified personnel should install this equipment. Failure to meet this requirement could cause severe injury and/or death, for which the manufacturer cannot be held responsible.
4. The installer must provide a main power switch that meets all applicable safety regulations.
5. Clearly indicate on the gate with the 2 warning signs that are included (visible from either side of the gate).
6. It is extremely unsafe to compensate for a damaged gate by increasing hydraulic pressure.
7. Devices such as reversing edges and photobeams must be installed to provide better protection for personal property and pedestrians. Install reversing devices that are appropriate to the gate design and gate application.
8. Before applying electrical power, be sure that the voltage requirements of the equipment correspond to your supply voltage. Refer to the label on your operator system.

USE

1. Use this equipment only in the capacity for which it was designed. Any use other than that stated should be considered improper and therefore dangerous.
2. When using any electrical equipment, observe some fundamental rules:
 - Do not touch the equipment with damp or humid hands or feet.
 - Do not install or operate the equipment with bare feet.
 - Do not allow small children or incapable persons to use the equipment.
3. If a gate system component malfunctions, turn off the main power before making any attempt to repair it.
4. Do not attempt to impede the movement of the gate. You may injure yourself as a result.
5. This equipment may reach high temperatures during operation; therefore, use caution when touching the external housing of the operator.
6. Learn to use the manual release mechanism according to the procedures found in this installation manual.
7. Before carrying out any cleaning or maintenance operations, disconnect the equipment from the electrical supply.
8. To guarantee the efficiency of this equipment, the manufacturer recommends that qualified personnel periodically check and maintain the equipment.

U.L. CLASS AND FAAC OPERATOR

Model	Duty Cycle	Typical Use
Class I: Residential Vehicular Gate Operator		
402 750	Limited duty	<ul style="list-style-type: none"> • Home use • Small apartment building, for example, up to 4 units in a building, with limited public access
422 760		
412 400		
620 640		
885		
Class II: Commercial/General Access Vehicular Gate Operator		
400 640	Continuous duty	<ul style="list-style-type: none"> • Apartment buildings • Very public access
620 885		
Class III: Industrial/Limited Access Vehicular Gate Operator		
400 640	Continuous duty	<ul style="list-style-type: none"> • No public access
620 885		
Class IV: Restricted Access Vehicular Gate Operator		
620 640	Continuous duty	<ul style="list-style-type: none"> • Prison rated security
885		

TECHNICAL DATA

THE 760 OPERATOR

Parameter	760 Standard	760 Longer Leaf
Ambient temperature, deg F (deg C)	-4 to 131 (-20 to 55)	
Maximum duty cycle, cycles per hour.	30	
Thermal cut out, deg F (deg C)	212 (100)	
Power voltage required, VAC*	115, $\pm 10\%$ or 230, +6 or -10%, 60 Hz	
Absorbed power, W	220	
Current drawn, A	230VAC= 1A, 115VAC= 1.5A	
Motor speed, rpm	1400	
Type of oil	Lubrication Engineers – MONOLEC 6105	
Height (excluding spline) \times width \times depth, in. (cm)	6 $\frac{1}{4}$ \times 10 $\frac{1}{4}$ \times 19 $\frac{1}{4}$ (15.9 \times 26 \times 49)	
Weight, lb (kg)	28 $\frac{1}{2}$ (13)	
Oil quantity, qt (l)	1 $\frac{1}{4}$ (1.2)	
Hydraulic locking	Opened and closed (CBAC)	Not Available (SB)
Maximum gate weight, lb (kg)	1760 (800)	
Maximum gate length, ft (m)	7 (2.1)	13 (4)
Maximum angle of rotation, deg	148 degrees	
90-deg opening time, sec	12 (plus additional time for soft-stop)	
Nominal torque, ft-lb (Nm)	399 (543)	

UNPACKING THE OPERATOR

When you receive your 760 Operator, inspect the shipping boxes for physical damage such as leaking oil or a torn carton. Then inspect the operator, the mounting box, and the control panel after you remove them from the boxes. Notify the carrier immediately if you note any damage because the carrier must witness the damage before you can file a claim.

As you unpack the boxes, insure that all parts listed to the right are included.

760 Operator	1
Load Bearing Box	1
Splined Collar	1
Standard bolts	2
Long bolts	2
Manual release housing (dog house)	1
A brass rod with an allen head end and white wheel	1
Stainless steel screws for the dog house	4
Triangular keyed manual release with white	1
Triangular manual release key	1

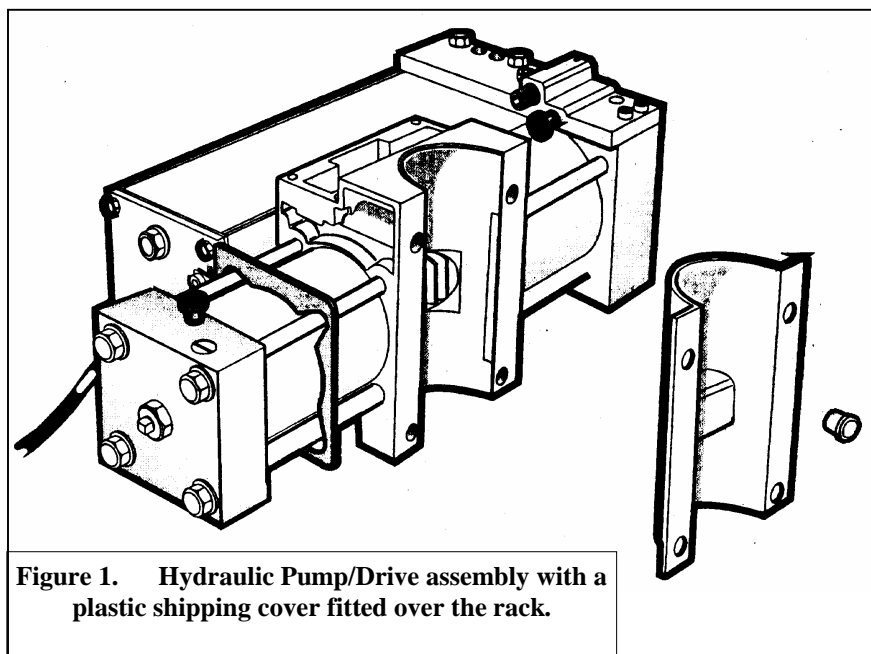

Figure 1. Hydraulic Pump/Drive assembly with a plastic shipping cover fitted over the rack.

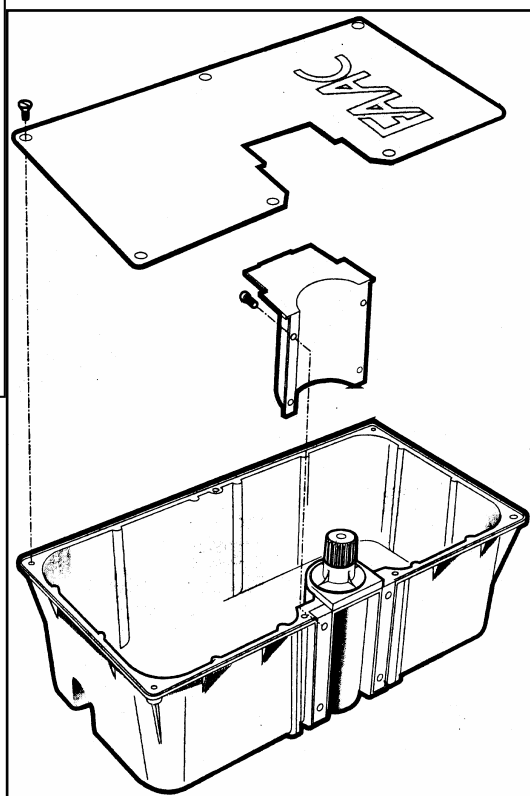

Figure 2. Cast Aluminum box with stainless steel lid; inside, a pinion cover is attached to the box with 4 screws.

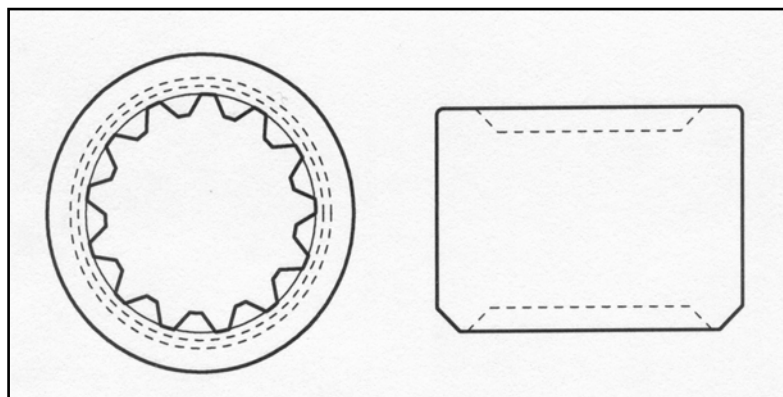

Figure 3. The Splined Collar, which comes on the shaft of the Load Bearing Box, attaches to the gate.

THE 760 OPERATOR

GENERAL CHARACTERISTICS

The 760 Operator with is a medium-duty operator designed to swing a gate leaf from an unobtrusive in-ground installation, thus preserving the appearance of the gate. A 760 Operator system consists of a hydraulic unit in an in-ground load bearing box and a control panel.

The 760 Operator is designed for gates swinging open up to a maximum of 148 degrees with a 90-deg opening time of 12 sec. The "soft-stop" of the 760 Operator brakes the movement of the gate during the last 10 deg of swing in both the opening and closing directions provided the gate opens 90 deg or more.

Once installed, the 760 Operator can be removed from the load bearing box without having to remove the gate.

For the 760 model, the axis of rotation of the gate leaf must fall along an imaginary plumb line that is **at least** 1 3/8 in. (3.5 cm) away from the gate side of the pillar/post.

The hydraulic locking of the 760 Standard models is a service feature that helps to keep a gate fully opened or fully closed. However, we recommend external locking mechanisms for any one of the following situations:

- You are installing the Model 760 SB or SBS
- The length of the gate leaf is 8 ft or more
- The installation requires tight security
- The site is subject to vandalism

- The site is subject to strong or very gusty wind
- You are installing a solid face gate

For gates with two leaves, an operator is installed on each leaf. The control panel can be programmed to swing one gate leaf slightly later than the other to allow for overlapping gate leaves.

The 760 Operator has two bypass valves that control the thrust of the gate leaves. You adjust the two bypass valves located on the 760 Operator to vary the force of the gate as it opens or closes.

Adjusting the bypass valves is necessary for the safety of both people and property. FAAC safety standards state that the gate should stop its movement if it encounters a force of more than 33 lb. The installer of the 760 Operator makes the necessary adjustments to insure safe pressures.

A Manual Release disengages the hydraulic system on the Standard model of the 760 Operator and allows you to operate the gate by hand from either side of the gate (see Figure 6).

Additional devices (such as photo-beams and inductive loops) should be installed to provide more complete safety for people and property.

The electronic control panel is a microprocessor-based controller that accepts a wide range of product accessories and reversing devices, thus allowing for a flexible gate system design.

INSTALLATION INSTRUCTIONS

Note: The following installation instructions assume you are fully capable of installing a gate operator. This manual does not instruct you in designing a gate, installing a gate, or basic electrical wiring. The installation tasks discussed in this manual are tasks particular to the 760 Operator.

PREPARING THE GATE

Before you install the 760 Operator, you must insure that the gate leaf meets the following criteria.

1. The gate leaf must not exceed the weight or length constraints for the operator you are installing (see page 4). If you are retrofitting the 760 Operator to an existing gate, you need to insure that the axis of rotation through the hinge(s) and splined shaft is perfectly plumb.
2. The distance between the gate post and the center of the gate hinge must be **at least** 1 3/8 in. (3.5 cm). (see Figure 4)
3. Make sure the gate leaf has positive stops in both the opening and closing directions (see Figure 5).
4. You need to determine a means of attaching the splined collar to the gate. If the gate leaf is steel, you may be able to weld the collar directly to the gate. If the bottom of the gate is more than 2 1/8 in. above grade level you will have to extend the collar with pipe or round stock. If your gate is aluminum or wood, you will have to weld the collar to a steel plate or shoe that can be bolted to the bottom of the gate.

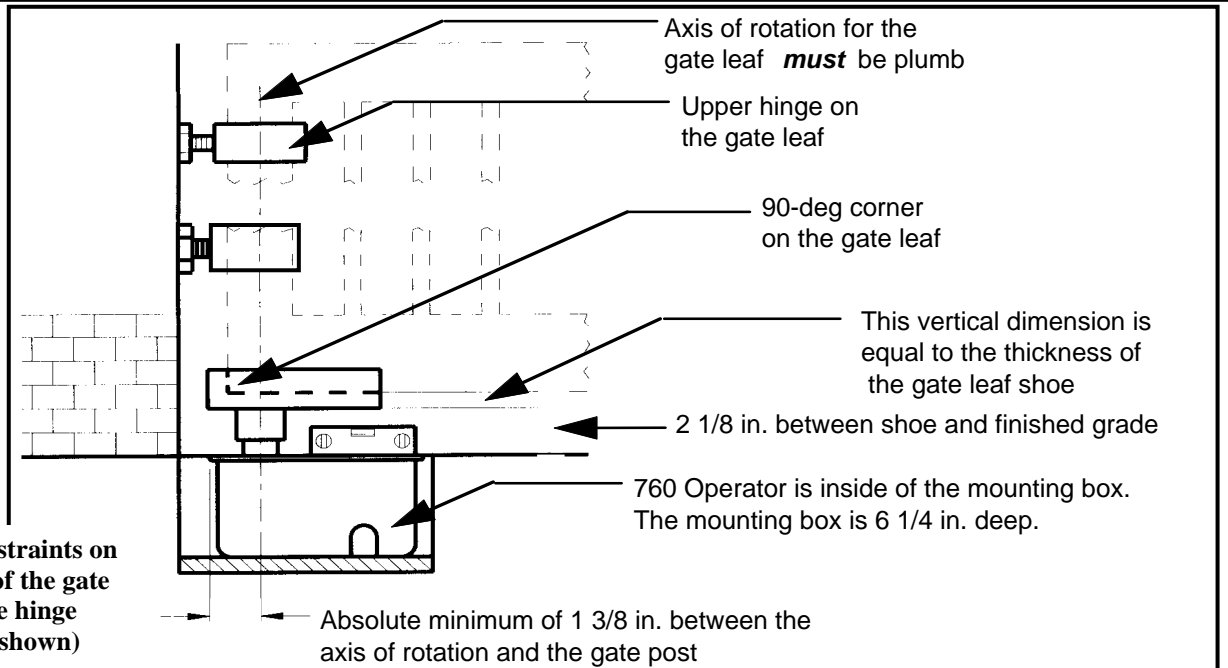
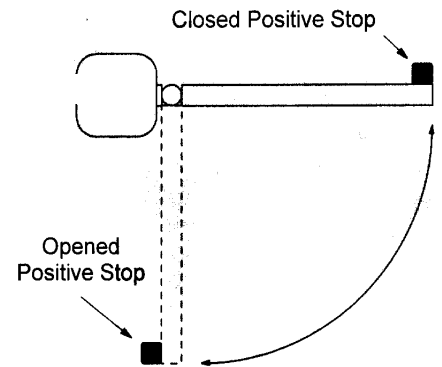

Figure 4. Constraints on the geometry of the gate leaf. (Single hinge installation shown)

Note: If you are installing the 760 Operator with an extension arm, some of the constraints do not apply to your gate leaf. See the section "Installing an Extension Arm" for more information (page 15).

Figure 5. Positive Stops



MANUAL RELEASE MECHANISM

Note: The 760 CBAC provides a Manual Release for manually operating the gate. Although the 760 SB comes with this release mechanism, it is not necessary to use this feature to release the gate. The SB has no internal locking and can be pushed manually at any time.

The Manual Release mechanism on the Standard models is a release device of the 760 Operator (see Figure 6). This device is accessible from both sides of the gate. You disengage the hydraulic operation of the operator by opening the access door (there is one on either side of the manual release housing), inserting the triangular key, and turning the key toward the gate post one full turn. Then you can move the gate slowly by hand to open or close the gate. Operating the gate by hand is necessary during installation and is useful during power failures.

To re-engage the hydraulic operation of the gate, turn the key away from the gate post until resistance is met.

1. Open the access door to the release device
2. Insert the key and turn it one full turn toward the gate post for release.

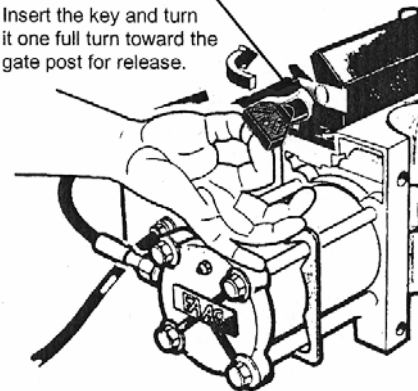

Figure 6. The Manual Release in the 760 Standard Operator

INSTALLING THE OPERATOR

Installing the 760 Operator consists of the following steps:

1. Install the load bearing box, electrical conduit, and drain pipe
2. Secure the load bearing box
3. Install the gate leaf shoe
4. Install the gate leaf
5. Install the operator in the load bearing box
6. Install the control panel and check the motor rotation
7. Adjust the hydraulic pressures
8. Fine-tune the hydraulic pressures

INSTALL THE LOAD BEARING BOX

You need to dig a hole for the load bearing box of the 760 Operator according to the dimensions shown in Figures 4 and 7. Accurately positioning the splined shaft of the pinion (inside the mounting box) beneath the gate hinge is critical. Proper alignment will ensure a full swing without binding.

Warning: You need to insure that the load bearing box is well drained by means of pipes, gravel drainage, or both, whatever is appropriate for your soil conditions. Use one of the access holes in the load bearing box for the drainage pipe leaving the box.

Install your electrical conduit through another hole in the load bearing box. Use conduit of sufficient size and quality to accommodate the high-voltage wiring that must run between the operator (in the load bearing box) and the control panel.

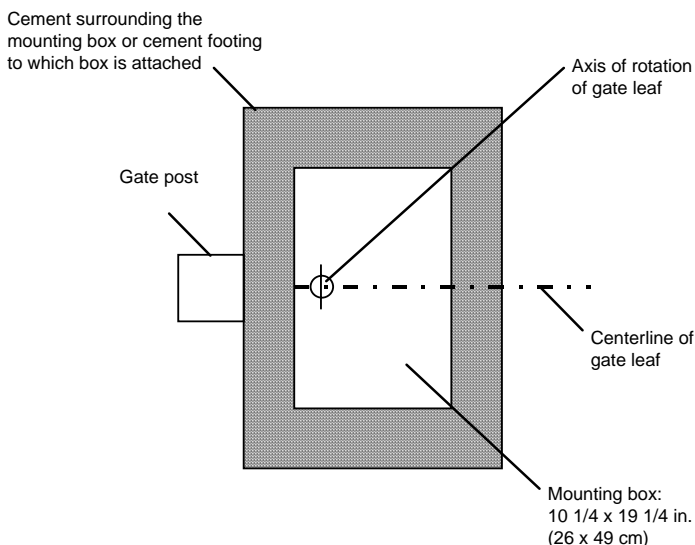

Figure 7. The orientation of the load bearing box and concrete when you secure the load bearing box

Caution: Be sure to conform to all applicable electrical codes

You next need to test fit the load bearing box in the hole. The fit must meet the following requirements:

1. The center of the splined shaft of the pinion must align perfectly with the axis of rotation for the gate leaf. *Use a plumb line to insure this vertical alignment.*
2. The cover of the load bearing box should be even with the finished grade beneath the gate, but more importantly, the top edges of the load bearing box must be level. *Use a level to insure this horizontal alignment.*

SECURE THE LOAD BEARING BOX

Next you need to fix the mounting box in place if it meets all the requirements for alignment. Precisely how you fix the box in place will vary according to your soil conditions and your installation site.

Note: No matter what your method of fixing the mounting box in place, use sufficient concrete to hold the mounting box in place when it is under the stresses inherent in hydraulically swinging the gate.

No matter how you secure the mounting box, if you use poured concrete, allow a minimum of two full days before you install the 760 Operator inside the mounting box.

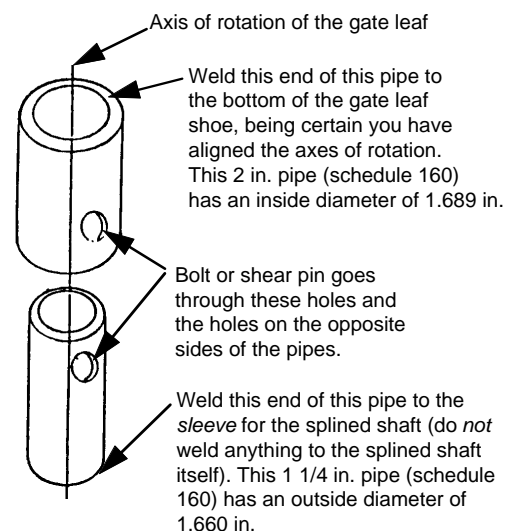

Figure 8. A sample shear-pin assembly.

INSTALL THE GATE LEAF SHOE

Note: Building a gate leaf shoe is not absolutely necessary. It is a method that will work in most applications. However, if you wish to weld the splined collar directly to the gate or attach it by some other means, feel free to do so.

Caution: Do not install the gate leaf shoe, even for test fitting, until any concrete beneath or around the mounting box has had a chance to set for a minimum of two full days.

If the vertical distance between the finished grade under the gate and the bottom of the gate leaf is more than 2 3/8 in. (see Figure 4), you need to do one of the following:

- Install a length of appropriately sized pipe between the splined collar of the operator and the gate leaf shoe.
- Construct a shear-pin assembly to accommodate the extra vertical distance. The assembly is welded to the bottom of the gate or gate leaf shoe on one end and to the sleeve for the splined collar on the other end (see Figures 8 and 9). Such an assembly protects the pinion and splined shaft in the event something hits the gate with great force.

Installing the gate leaf shoe involves making the gate leaf shoe, positioning it, and welding it to the splined collar.

The gate leaf shoe is designed to carry the weight of the gate leaf and transfer the weight to the splined shaft of the pinion.

Note: The gate's axis of rotation may fall within or outside the body of the gate leaf.

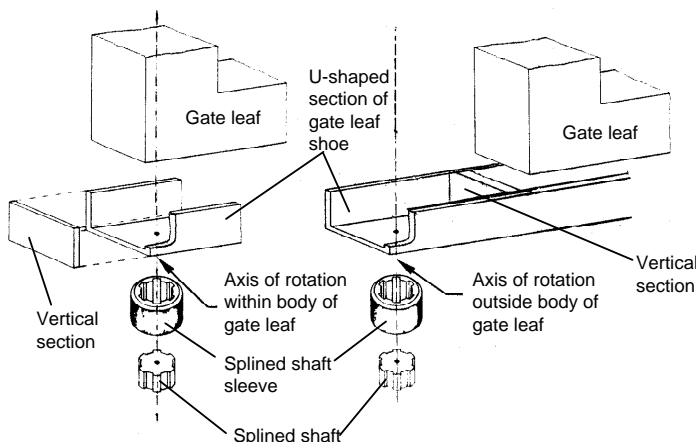

Figure 9. Parts of the gate leaf shoe

The shoe is made of a U-shaped section and a vertical section (see Figure 9). Later you will weld the bottom of the U-shaped section to the sleeve for the splined shaft (or to the shear-pin assembly, which is welded to the splined collar).

Since the gate leaf shoe holds the gate leaf, both sections must be made of steel at least 1/4 in. (0.6 cm) thick. The U-shaped section of the shoe must be a minimum of 5 3/4 in. (2.1 cm) long and must be as wide as the gate leaf is thick and must fit as tightly as possible to minimize leaf movement within the shoe (see Figure 10).

Construct the U-shaped section of the shoe and verify that it fits around the gate leaf. Position the U-shaped section over the splined shaft so that the leaf's axis of rotation will fall within the minimum dimensions shown in Figure 10.

On the U-shaped section of the shoe, mark the position for the leaf's axis of rotation. Next, drill a pilot hole in the U-shaped section to mark the axis of rotation point and mark the position for the placement of the vertical section of the shoe.

Next you need to position the splined collar (or the shear-pin assembly) on the bottom side of the U-shaped section of the shoe as shown in Figure 9. In positioning the splined collar, meet the following two requirements:

1. On the bottom of the U-shaped shoe section, accurately center the sleeve around the pilot hole that marks the axis of rotation. Accuracy is important.
2. Center one notch on the sleeve along the centerline of the gate leaf (see Figure 11). You can then align this centered notch with the punch mark on the splined shaft of the pinion as a reference in case you ever need to remove the shoe later.

Caution: NEVER weld the splined shaft of the pinion to the load bearing box.

Spot-weld the splined collar into place on the bottom of the shoe's U-shaped section. If you are using the shear-pin assembly, spot weld the splined collar to the bottom of the shear-pin assembly, and spot weld the top of the shear-pin assembly to the bottom of the shoe's U-shaped section. (You must still meet the two alignment requirements noted above even if you are using the shear-pin assembly.)

Next you must test the temporarily welded position of the sleeve. Fit the sleeve over the splined shaft with the U-shaped section aligned in the gate leaf's fully closed position. Verify that the axis of rotation falls through the hinge(s), the pilot hole, and the center of the splined shaft.

If the axis of rotation alignments are correct, then permanently weld the sleeve for the splined shaft to the bottom of the U-shaped section of the shoe.

Also, you now need to weld the pilot hole closed, and you need to weld the vertical section of the shoe to the U-shaped section of the shoe.

Lubricate the splined shaft with grease and place the finished gate leaf shoe assembly over the shaft in the closed position.

Next, very slowly open and close the gate leaf a few times to see if it moves smoothly and evenly through its entire path.

INSTALL THE OPERATOR IN THE LOAD BEARING BOX

NOTE: The installation of the operator assumes you have installed the load bearing box and the gate leaf. Do *not* proceed with installing the operator until the load bearing box and gate leaf have been installed.

REMOVE COVERS

To install the 760 Operator (see Figure 12), first prepare the splined shaft in the mounting box by removing the pinion cover (Figure 13). To remove the pinion cover, remove the four bolts holding the cover.

Next, remove the plugs holding the rack cover to the 760 Operator (see Figure 14). Be sure to keep track of the plugs and the rack and pinion covers in case you ever need to remove the operator for repair.

POSITION THE GATE LEAF

The 760 Operator is shipped to you with the hydraulic ram in the half-opened position. This means that before you mate the pinion and the rack, you **must** open your gate leaf to the half opened position to assure the maximum travel for your gate leaf in the opening and closing directions.

The greater the arc of swing in your gate leaf (the closer you are to the maximum swing of 148 degrees), the more important it is that you be *exact* in opening the gate to the half-opened position. If necessary, measure the distance.

If your gate leaf opens less than 90 deg, you can have 10 deg of braking in only one direction. To assure any braking whatsoever, you must compute the opening distance for your gate leaf to use before you mate the rack and pinion. For braking on closing, determine what 3/4 the length of your gate leaf is, and open the gate leaf that distance from the closed position (see Figure 15).

MOUNT THE OPERATOR

Once the gate leaf is in the proper partially opened position, install two lock washers and the two long-headed bolts through the two holes in the bottom of the 760 Operator (see Figure 16). Mate the rack in the operator to the pinion in the mounting box. Next, insert the two bolts and lock washers through the top of the operator and into the mounting box (see Figure 16). Tighten all four bolts securely.

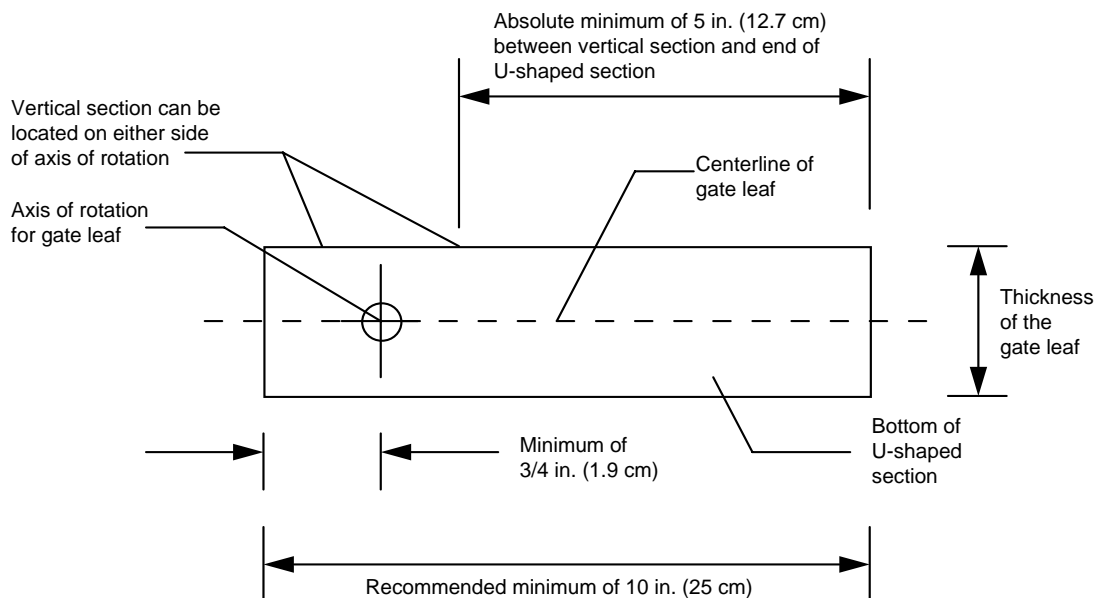

Figure 10. Top view of the U-shaped section of the gate leaf shoe

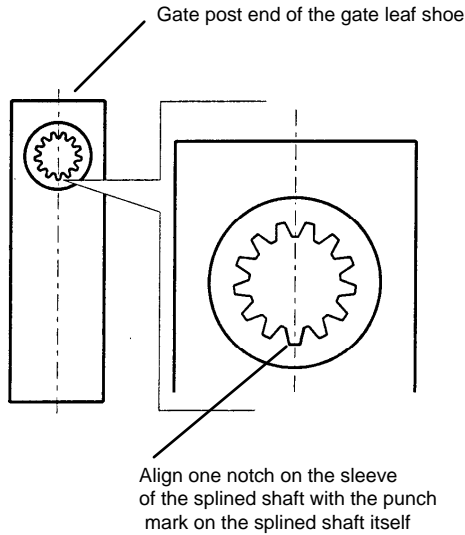

Figure 11. Center one notch along the centerline of the gate leaf shoe and place over the punch mark on the splined shaft.

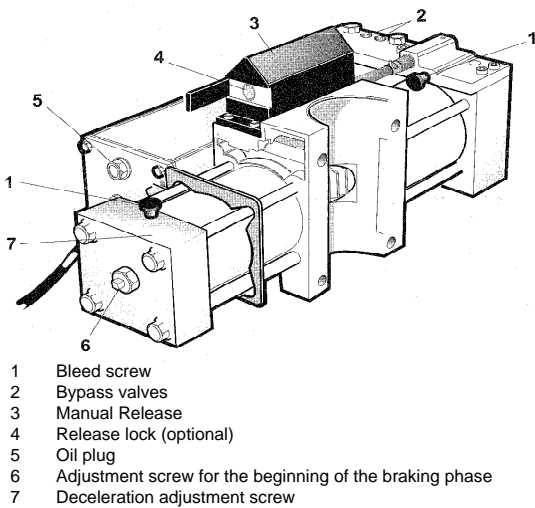

Figure 12. The parts of the 760 Operator with soft stop.

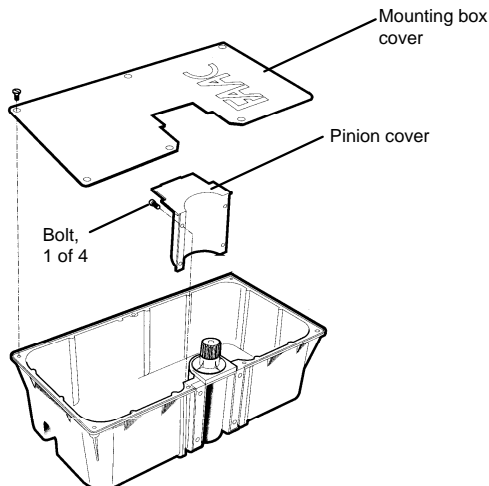

Figure 13. Remove the pinion cover by removing the snap-on bolts that hold it to the pinion assembly

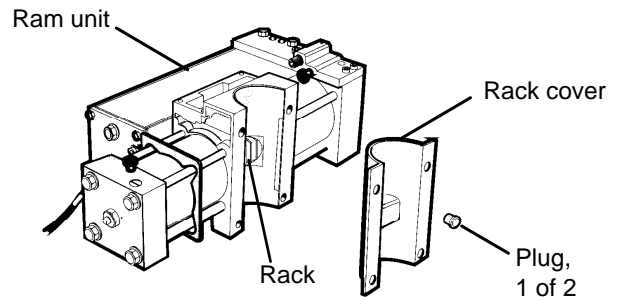

Figure 14. Remove the rack cover by removing the plugs that hold it on the 760 Operator

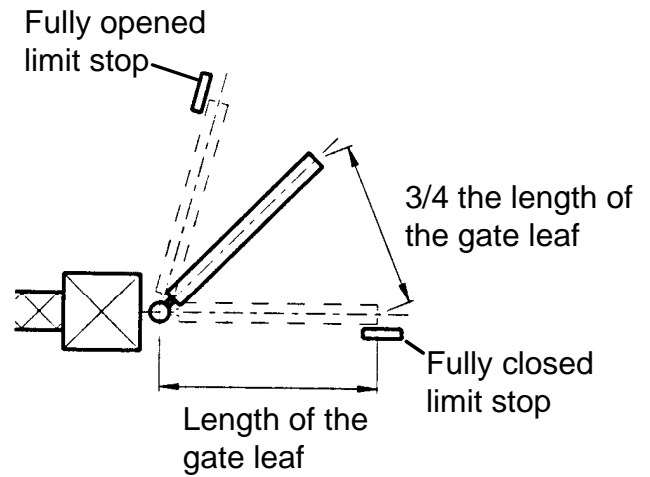

Figure 15. On a gate leaf that opens less than 90 degrees, properly position the gate leaf before installing the 760 Operator.

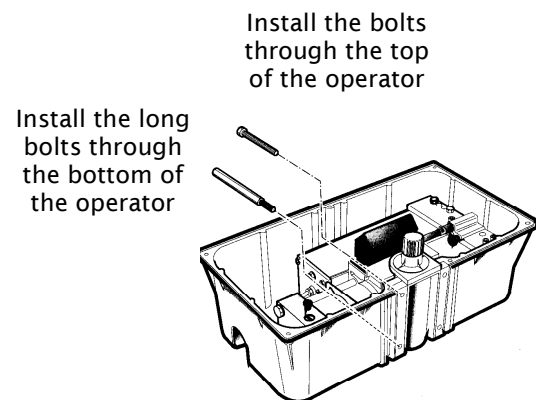

Figure 16. Anchor the Operator to the mounting box and pinion assembly.

INSTALLING THE 455 D CONTROL PANEL

Installing the control panel consists of the following general steps:

- Connecting the main power to the control panel
- Connecting the activating device
- Connecting the operator to the control panel
- Checking the direction of the motor's rotation
- Connecting other devices to the control panel
- Set operating modes

The installer is responsible for grounding the gate and operator systems, for providing the main power breaker switch, and for making sure that the entire gate system meets all applicable electrical codes.

For the complete 455 D Control Panel Installation Instructions, see pages 20 - 31 of this manual.

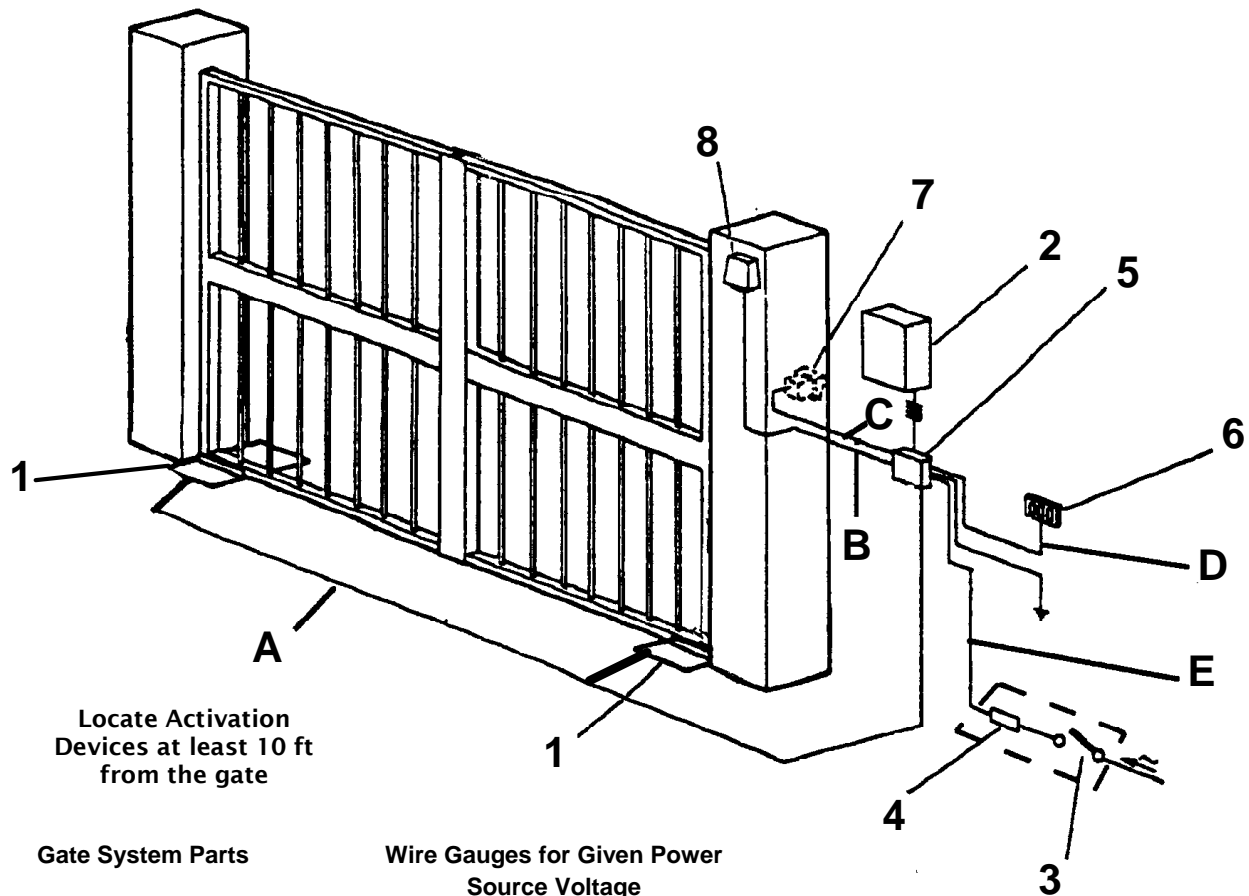

Gate System Parts

- 1 760 Operator in mounting box
- 2 760 Control Panel Box
- 3 Main Power Switch
- 4 Circuit Breaker
- 5 Main Junction Box
- 6 Activation Device for 760 Operator
- 7 Activation Device for 760 Operator
- 8 Radio Receiver

Wire Gauges for Given Power Source Voltage

- 220 VAC**
- A 4 x 14 AWG
 - B 3 x 18 AWG
 - C 5 x 18 AWG
 - D 5 x 18 AWG
 - E 4 x 14 AWG up to 414 ft (126 m)

Figure 17. Typical layout of gate system with 760 Operators

ADJUST THE HYDRAULIC PRESSURES

WARNING! The pressure valves are not preset at the factory and may operate the gate leaf with enough force to endanger people and seriously damage the gate leaf itself.

The green and red screws on the top of the oil reservoir of the 760 Operator are the bypass valve adjustments that control the force of the gate leaf's opening and closing momentum (see Figure 18). For either valve, turning the screw clockwise increases the pressure and turning it counterclockwise decreases the pressure.

The green screw always controls the clockwise rotation of the splined shaft, and the red screw always controls the counterclockwise rotation of the splined shaft.

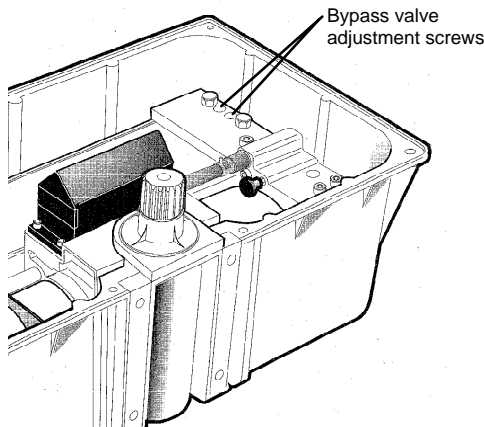

Figure 18. Decrease the pressures controlled by the bypass valve screws completely before you operate the gate electronically

FINE-TUNE THE HYDRAULIC PRESSURES

The pressure a gate leaf applies to an obstacle in its path is determined by the bypass valve adjustment. The safety standards of FAAC International, Inc., recommend that the gate should stop when it meets with a force of more than 33 lb (15 kg).

WARNING! The pressure valves may operate the gate leaf with enough force to endanger people and seriously damage the gate leaf itself. Increase the pressures in small increments (1/4 turn), and set the pressure adjustments at the *minimum* level necessary for the gate's operation.

Fine tune the pressures for both opening and closing after you have installed the control panel for the 760 Operator. Set the pressures at the *minimum* necessary to open or close the gate leaf.

Note: The red and green screws are not a speed adjustment. The motor speed and pump displacement are constant.

Warning! Do not increase the pressure adjustments excessively in an attempt to speed up the gate. Doing so can increase the risk of serious injury.

ADJUST THE BEGINNING OF THE BRAKING PHASE

You need to adjust the start of the braking phase for opening and closing. You adjust the braking to no more than 10 deg before fully closed and fully opened. (Figure 19) shows the location of the adjustment screws for the beginning of the braking phase.

Note: The 760 Operator ships from the factory with the brake adjustment screw set with no braking.

If you have a CBAC model with hydraulic locking, you first need to use the Manual Release to disengage hydraulic operation of the 760 Operator before you adjust the screws for the beginning of the braking phase.

To adjust the start of the braking phase, first make sure the brake intensity screws are not tightened completely. Unscrew them at least a couple of turns (see Figure 20).

Then, place the gate leaf in the closed position against the positive stop. Next, loosen the brass lock nut from the brake adjustment bolt. Then, using an 8mm open end wrench, turn the square-headed brake adjustment bolt counterclockwise until you feel the bolt tightening. (see Figure 20).

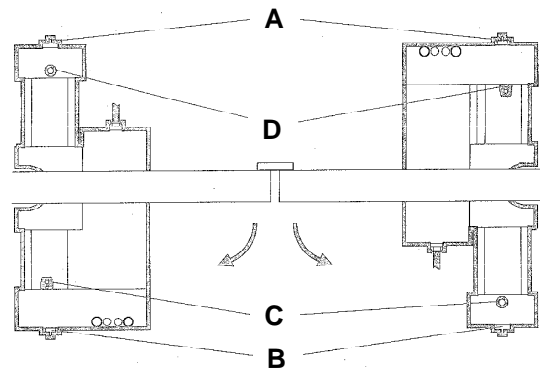

A	B	C	D
Brake adjustment bolt for closing	Brake adjustment bolt for opening	Opening bleed screw on CR models	Closing bleed screw on CR models

Figure 19. The location of the brake adjustment bolts for the beginning of the braking phase and the bleed screws.

Manually, move the gate leaf to the opened position against the positive stop. Loosen the brass lock nut for the brake adjustment bolt. Next, turn the square-headed brake adjustment bolt counterclockwise until you feel the bolt tightening.

Note: If your gate leaf opens less than 90 deg, setting the beginning of the braking phase may have no effect on the gate leaf. The only way to adjust the beginning of the braking phase is with the position of the gate leaf and the rack when you mate the rack and pinion.

Note: If you wish the braking of the operator in the opening or closing direction to start at less than 10 deg, turn the corresponding bolt clockwise. There is no way to begin braking at more than 10 deg.

Note: After making these adjustments, if the gate doesn't slow down in both the open and closed positions, you may need to remove the 760 operator and realign the operator rack with the next tooth on the pinion.

ADJUST THE BRAKING INTENSITY

Figure 20 shows you the location of one of the braking intensity screws; the other is similarly located on the other end of the operator. Figure 20 shows that you turn the adjustment screws clockwise to increase the intensity of the braking and counterclockwise to reduce the intensity of the braking.

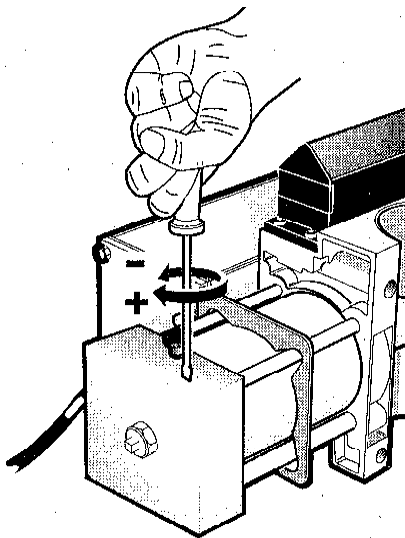

Figure 20. Turn the adjustment screw clockwise to increase the braking and counter-clockwise to decrease the braking.

ASSEMBLE AND INSTALL THE MANUAL RELEASE

The parts for the Manual Release are shipped in the shrink-wrapped package with other small parts.

To assemble the Manual Release, lay open the black plastic Manual Release housing so that the FAAC logo faces downward. You need to place in the ribbing on one side of the black plastic the brass gear assembly and the plastic gear assembly. (see Figure 21).

Then you can gently fold the black plastic housing around the gear assemblies. The black plastic housing should snap shut if you have the access doors to the key holes out of the way.

The brass rod that extends from the plastic gear assembly and out of the black plastic housing has a 6-mm hex head on the visible end. You need to slide this hex head into the brass fitting of the 760 Operator that is located on the same end as the bypass valve adjustment screws (see Figure 22).

Once the head is seated, the rest of the Manual Release assembly should fit into place on the top of the 760 Operator. Use the four screws in the parts package to hold the Manual Release housing in place.

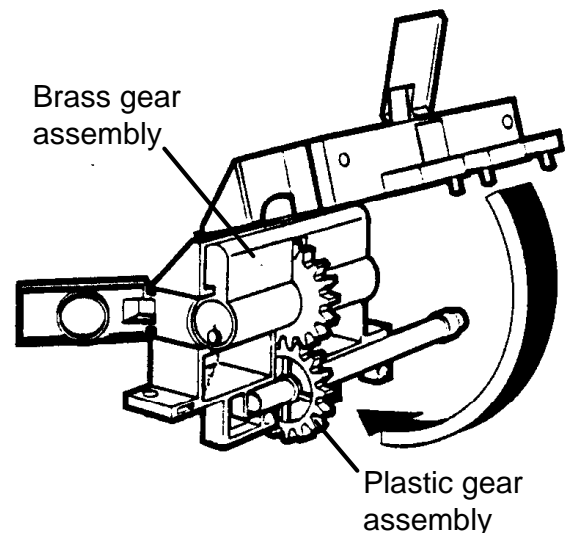

Figure 21. Assemble the Manual Release mechanism

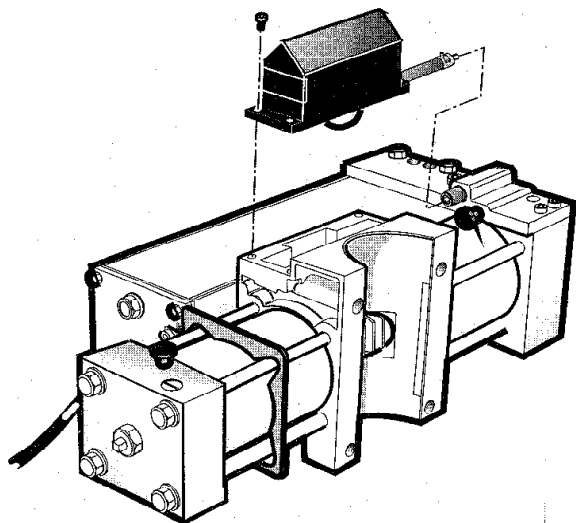

Figure 22. Install the Manual Release mechanism

INSTALLING AN EXTENSION ARM

Some gate installations do not meet the geometrical constraints shown in Figure 4. In those situations, the 750/760 Extension Arm option can be used to install a 760 operator.

The geometrical constraint for using the 750/760 Extension Arm is that the center of the splined shaft on the mounting box *must* be within 6 in. (15.25 cm) of the axis of rotation of the gate leaf.

WARNING! The farther away the splined shaft is from the gate's axis of rotation, the greater the risk of danger from pinch points.

Install the mounting box so that the splined shaft is as near as possible to the gate's rotation axis and is directly beneath the center of the fully closed gate leaf.

You need to position the extension collar (see Figure 23) so that it smoothly slides within the extension U from the fully closed to the fully opened position. Note that the position of the extension collar is affected by the overlap of the extension bar and extension U.

Attach the 750/760 extension collar to the bottom of the gate leaf with a 1/2 inch bolt.

Weld together the extension bar and extension U according to Figure 23.

Caution: Do not weld anything to or on the inside of the sleeve of the splined shaft.

Next, weld the outside of the sleeve for the splined shaft solidly to the opposite side facing down on the extension bar. (See Figure 23 b)

Follow the rest of the instructions for installing the 760 Operator. With an extension arm, you need not worry about installing a gate leaf shoe nor about installing the gate leaf in the shoe. Instead, you will install one end of the welded extension arm over the splined shaft and the other end around the extension collar.

In addition, you will need to provide a washer beneath the extension collar to keep the extension U from falling off the collar. You also need to shield any pinch points around the extension arm for safe operation.

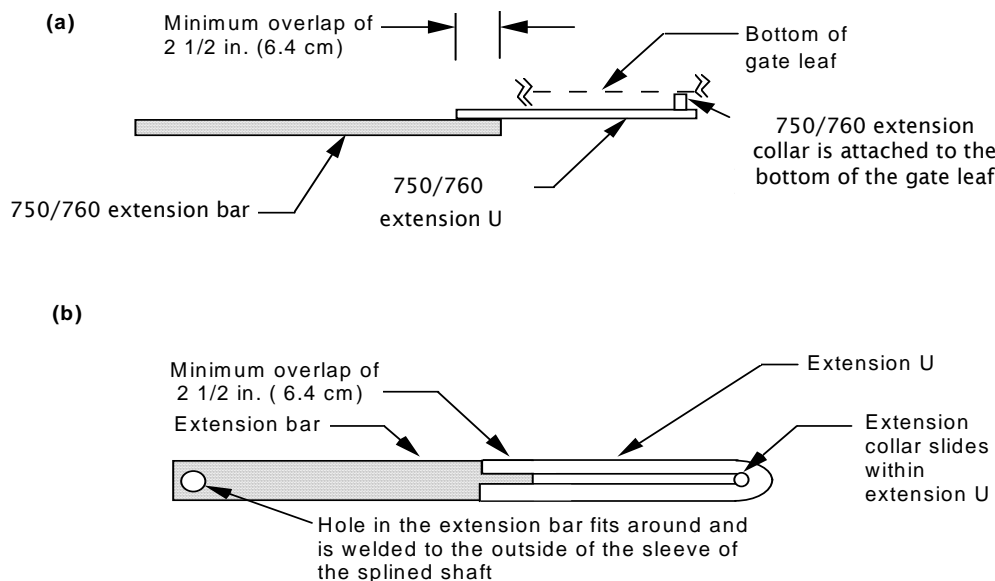
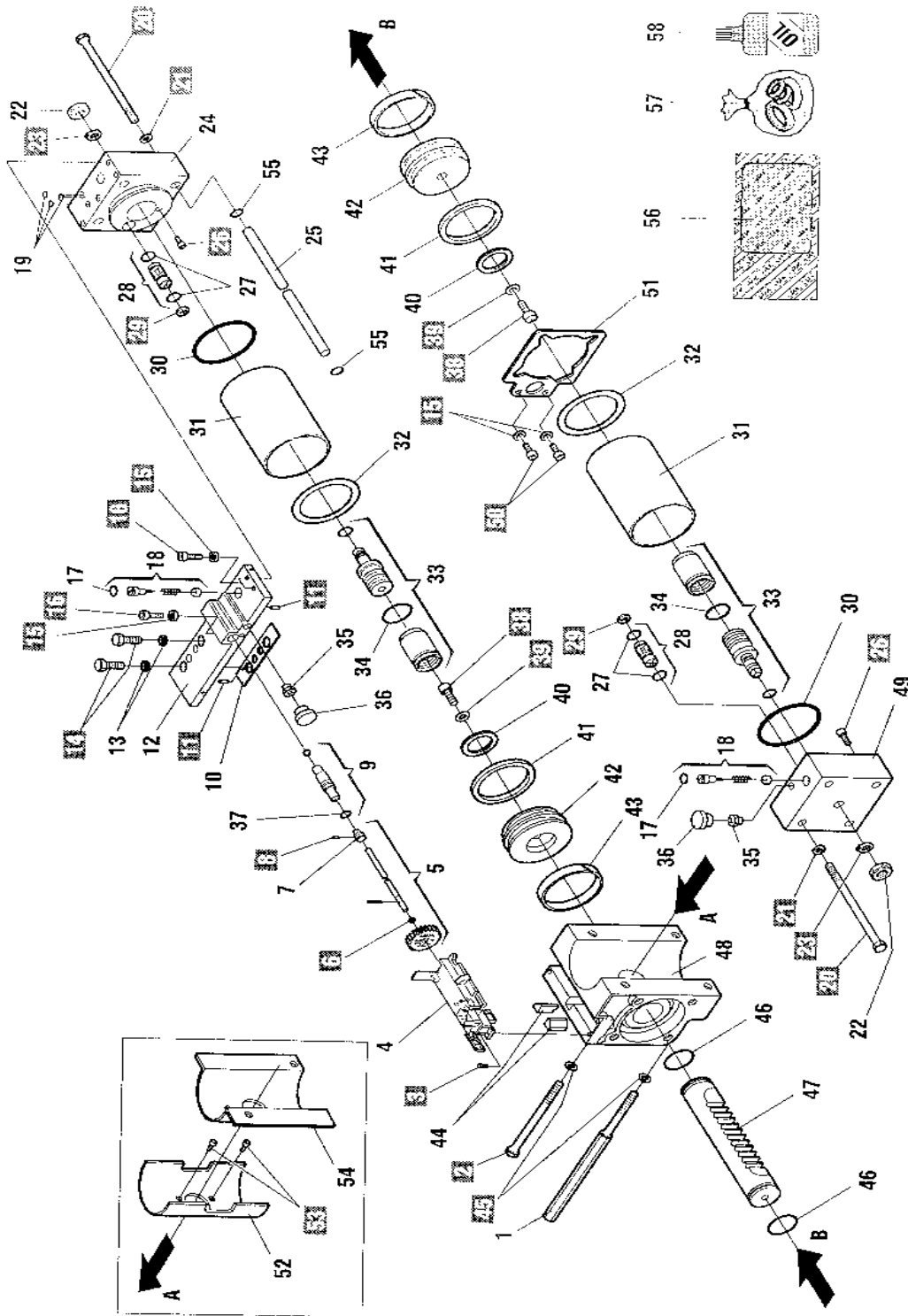

Figure 23. The 760 Extension Arm, (a) side view and (b) top view

760 OPERATOR



760 PARTS LIST

POS	PART NO.	DESCRIPTION	QTY
1	7019345	Mounting Bolt (bottom)	2
2	7011345	Mounting Bolt (top)	2
3	7014801	Stainless Steel Screw (doghouse)	4
4	7201295	Manual Release Housing	1
5	4246385	Manual Release Rod	1
6	N/A	Snap Ring	1
7	N/A	Manual Release Rod End	1
8	N/A	Retaining Pin	1
9	4180295	Manual Release	1
10	7099595	Gasket (manifold)	1
11	N/A	Parallel Pin	2
12	499762	Manifold	1
13	7039285	Copper Washer	2
14	71101115	Banjo Bolt	2
15	N/A	Lock Washer	5
16	N/A	Allen Head Bolt	3
17	N/A	O-Ring (with part No. 18)	2
18	4180265	Brass ByPass Cap (break)	2
19	7090010015	O-Ring	3
20	7011355	Flange Bolt (10 x 150mm)	8
21	N/A	Lock Washer	8
22	N/A	Jack Counter Nut Brass Jam Nut	2
23	N/A	Snap Ring	2
24	499760	Flange (manifold side)	1
25	7361365	Retract Tube	1
26	N/A	Allen Head Screw	2
27	N/A	O-Ring (with part No. 28)	4
28	4404085	Lock Valve	2
29	N/A	Snap Ring	2

POS	PART NO.	DESCRIPTION	QTY
30	N/A	O-Ring (flange)	2
31	7366135	Cylinder	2
32	7099585	Gasket (cylinder)	2
33	7350275	Ramping Piston	2
34	N/A	O-Ring (ramping piston)	2
35	7246025	Zert Fitting	2
36	7110045	Debris Cover	2
37	N/A	O-Ring (manual release)	1
38	N/A	Allen Head Bolt (piston)	2
39	N/A	Lock Washer	2
40	7094115	Piston (red internal)	2
41	7092025	Piston Seal	2
42	7350275	Piston	2
43	7049195	Piston Seal (inner)	2
44	7119485	Vibration Dampener	2
45	N/A	Lock Washer (coated)	4
46	N/A	O-Ring (rack)	2
47	7193205	Rack	1
48	7160505	Ram Body	1
49	499761	Flange (non manifold)	1
50	N/A	Allen Head Screw	2
51	7224215	Bracket (pump to drive)	1
52	7099575	Gasket (drive to box)	1
53	N/A	Self Taping Screw	2
54	7276015	Rack Protecting Cover	1
55	7090665	O-Ring (retracting tube)	2
56	3905515	Skin Pack (mounting hardware)	1
57	2176*	Seal Kit	1
58	6105*	1 Qt Monolec Oil	1

* Included in Kit #2167A*

* * 220V 1400RPM Motor Part #77000415

760 CBAC OPERATOR

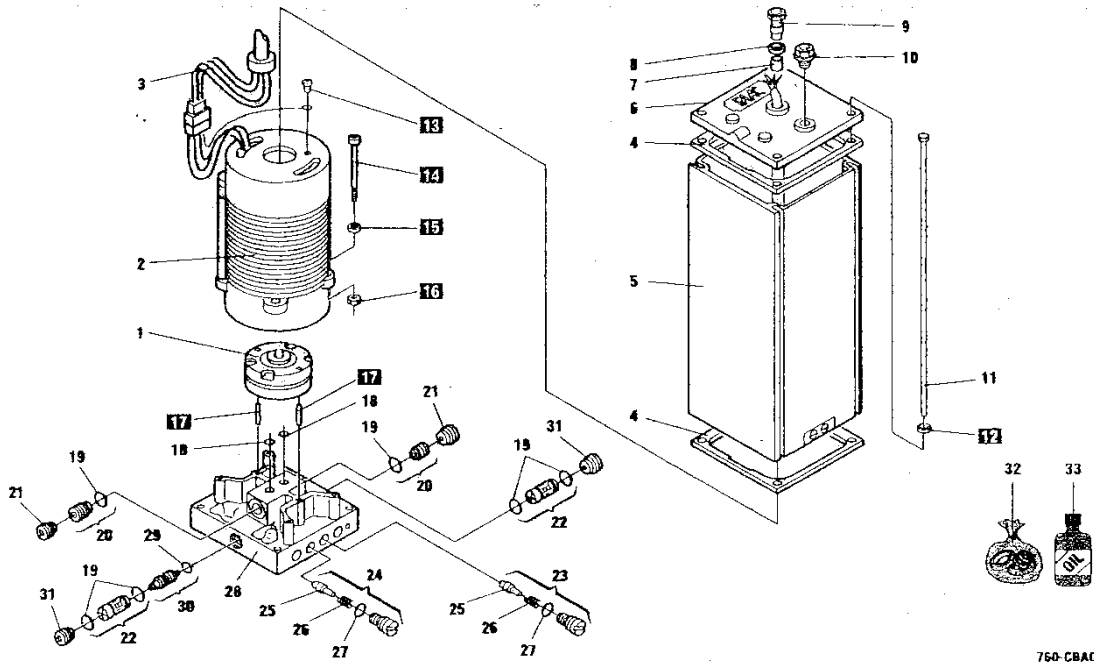

PARTS LIST

POS	PART NO.	DESCRIPTION	QTY
1	3204385	Lobe Pump	1
2**	77000425	115 V 1400 RPM Motor	1
3	7514125	Electric Power Cord	1
4	7099315	Flange Gasket	2
5	7450115	Body (pump housing)	1
6	N/A	Flange (Top Housing)	1
7*	2581	Fiber Washer	1
8*	7039305	Strain Relief Brass Washer	1
9*	7109155	Strain Relief Nut	1
10	7110015	Filler Cap	1
11	7230385	Tie Rod Pump (760)	4
12	N/A	Star Washer Stainless Steel	4
13	2274	Vent Screw (4x8mm)	1
14	2365	Motor Bolt (4x50mm)	4
15	2366	Lock Washer (4mm)	4
16	2367	Hex Nut (4mm)	4
17	N/A	Pump Pin (4x28mm)	2

POS	PART NO.	DESCRIPTION	QTY
18	7090010015	O-Ring	2
19	7090010015	O-Ring	6
20	4404065	Inlet Valve	2
21	7049005	Valve Retainer	2
22	4404085	Lock Valve	2
23	4180135	Green By-Pass Cap	1
24	4180145	Red By-Pass Cap	1
25	7310315	By-Pass Cap	2
26	7210025	By-Pass Spring	2
27	7090150	O-Ring (By-Pass Cap)	2
28	4994075	Valve Body	1
29	7090300	O-Ring (Shuttle Piston)	1
30	4180285	Shuttle Piston	1
31	7049005	Valve Retainer (Brass)	2
32	2170*	Seal Kit	1
33	6105*	1 Qt Monolec Oil	1

* Included in kit # 7109235

** 220V 1400 RPM Motor Part # 77000415

760 LOAD BEARING BOX

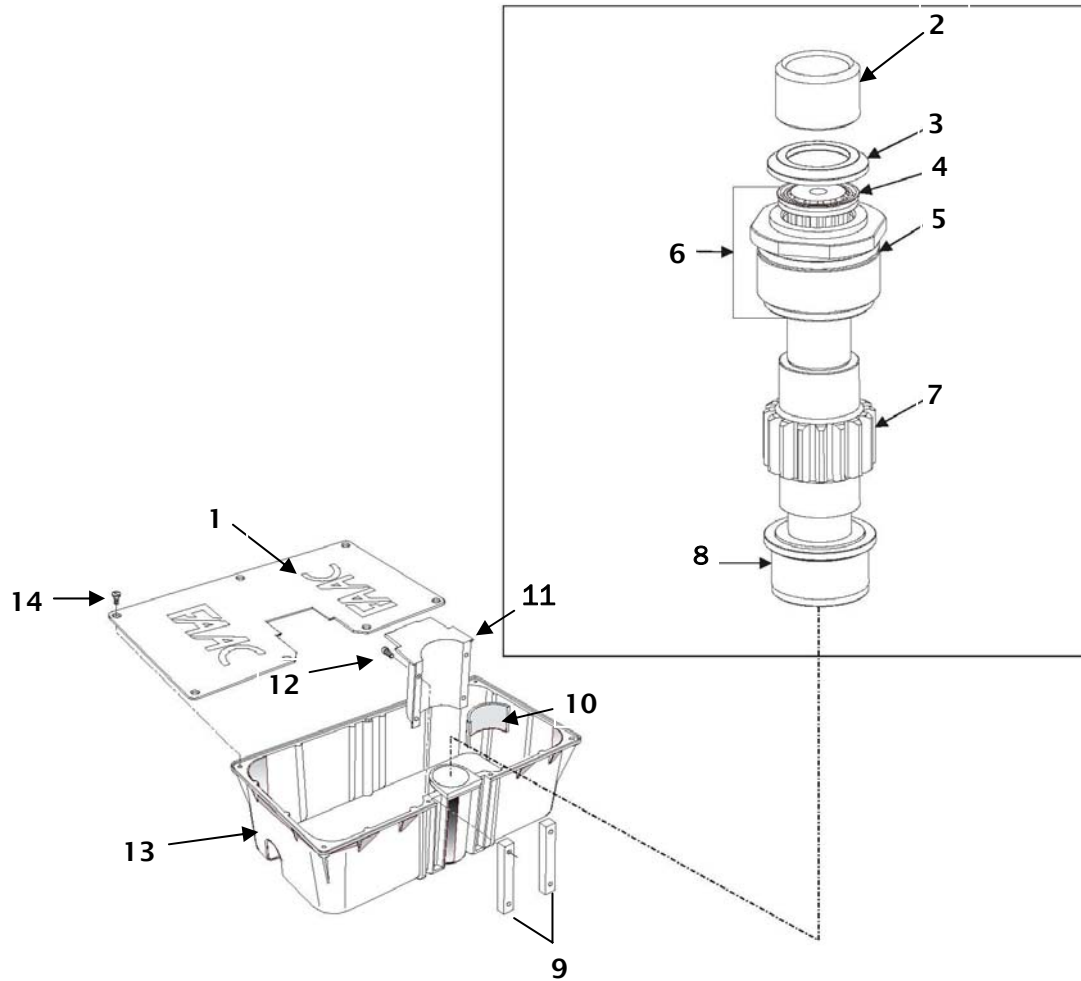

PARTS LIST

POS	PART NO.	DESCRIPTION	QTY
1	7276005	Load Bearing Box Cover	1
2	7309095	Splined Collar	1
3	7093225	Dust Cover	1
4	7095075	Seal (Top/Inner)	1
5	7090765	Bushing (Upper)	1
6	3907535	Bushing (Upper) & Seal Combo	1
7	7192475	Pinion (Shaft)	1

POS	PART NO.	DESCRIPTION	QTY
8	3907525	Bushing (Lower)	1
9	7280885	Mounting Bar	2
10	7099575	Gasket (Drive to Load Bearing Box)	1
11	N/A	Rack Cover	1
12	N/A	Galvanized Screw	4
13	490098	Load Bearing Box (Complete)	1
14	2070	Stainless Steel Screw (6 x 10mm)	7

THE 455 D CONTROL PANEL

GENERAL DESCRIPTION

The FAAC 455 D control panel is used to operate the following models.

Swing gate operators:

400	412
402	750
422	760

Barrier gate operators:

610/615

The 455 D programming controls the following:

Operating logic: A, S, E, EP, B, and C logics available.

Reversing device behavior: Choose whether a triggered reversing device during closing immediately reverses gate movement or stops the gate and reverses gate movement when no longer triggered.

Torque or Pressure: Force adjustment for the 412 operator. Adjustable from 0 to 50.

Caution: For all hydraulic operators, the torque **must** be programmed to the maximum (50) setting.

Pause time between opening and closing: adjustable from 0 to 4 minutes.

Opening/Closing time: adjustable from 0 to 2 minutes.

Leaf delay on closing: adjustable from 0 to 4.1 minutes.

The 455 D control panel should be installed in an enclosure that is conveniently located as close as possible to the gate operator. All electrical connections from the control panel to the operator must be made in a weatherproof junction box.

The 455 D control panel requires a single-phase power supply voltage (115 VAC [$\pm 10\%$] or 230 VAC [$+6$ or -10%], 50-60 Hz). The power supply should be protected by a 15 amp dedicated circuit breaker (not provided).

The installer is responsible for grounding the operator system, for providing the main power

breaker switch, and for making sure that the entire gate system meets all applicable electrical codes. The installer should refer to the installation manual for a given operator for more information.

NOTE: An installation is U.L. compliant only when you install the FAAC operators according to the UL325 standards.

INSTALLING THE 455 D CONTROL PANEL

Locate the control panel in the most convenient position possible, considering the movement of the gate.

Installing the control panel consists of the following general steps:

- Connecting the main power to the control panel
- Connecting the activating device
- Connecting the operator to the control panel
- Checking the direction of the motor's rotation
- Connecting other devices to the control panel
- Set operating modes

CONNECT THE MAIN POWER SUPPLY

WARNING! Turn the main power off before you make any electrical connections or before programming.

Wire the main power supply to control panel terminals in block J3 (see Figures 1-CP and 2-CP). The installer is responsible for insuring that a separate, grounded circuit protected by a circuit breaker is between the control panel and the main power supply. All wiring should conform to applicable electrical codes, and all wiring and fittings should be weatherproof and/or suitable for burial.

Connect the ground to the grounding terminal in block J3 and connect the power wires to the terminals labeled N (neutral) and L (line).

NOTE: For a 230V system, a neutral is not needed. Connect one 115V line to the L (Line) and a second 115V line to the N (Neutral).

CONNECT THE OPERATOR(S) TO THE CONTROL PANEL

WARNING! Turn the main power off before you make any electrical connections or before programming.

CAUTION: The operators are grounded only by the grounded circuit the installer provides.

USING A JUNCTION BOX

If an operator is more than 2 ft away from the control panel, you must use a junction box for connection. Use a U. L. Listed cord grip where the operator cord enters the junction box.

Note: If you have a one-leaf gate design, the operator **must** be connected to Motor 1 (terminals 1,2, & 3)

To wire up motor 1, connect the white wire to terminal 1(on the J4 terminal strip), the black wire to 2, and the red wire to 3. Wire each leg of the capacitor (supplied) to terminals 2 & 3.

Note: If you want to delay the closing of one gate leaf in a two-leaf gate design, be sure to connect its operator to Motor 1.

In order to wire motor 2 in a bi-parting system, connect the white wire to terminal 4 (on the J4 terminal strip), the black wire to 5, the red wire to 6. Wire each leg of the capacitor (supplied) to terminals 5 & 6.

CHECK THE MOTOR'S DIRECTION OF ROTATION

WARNING! The pressure valves are not preset at the factory and may operate a gate leaf with enough force to endanger people and seriously damage the gate leaf itself. Refer to your operator's installation manual to decrease the hydraulic pressures before checking the motor's direction of rotation.

After you have connected the main power supply, and the operator(s) to the control panel, you need to check the direction of rotation for each operator motor in your gate design.

Note: To check a motor's direction of rotation, you must have three closed circuits on terminal block J1. Install one circuit between terminals 11 and 16, another circuit between terminals 12 and 19, and another circuit between terminals 13 and 19.

Figure 1-CP. The 455 D Control Panel

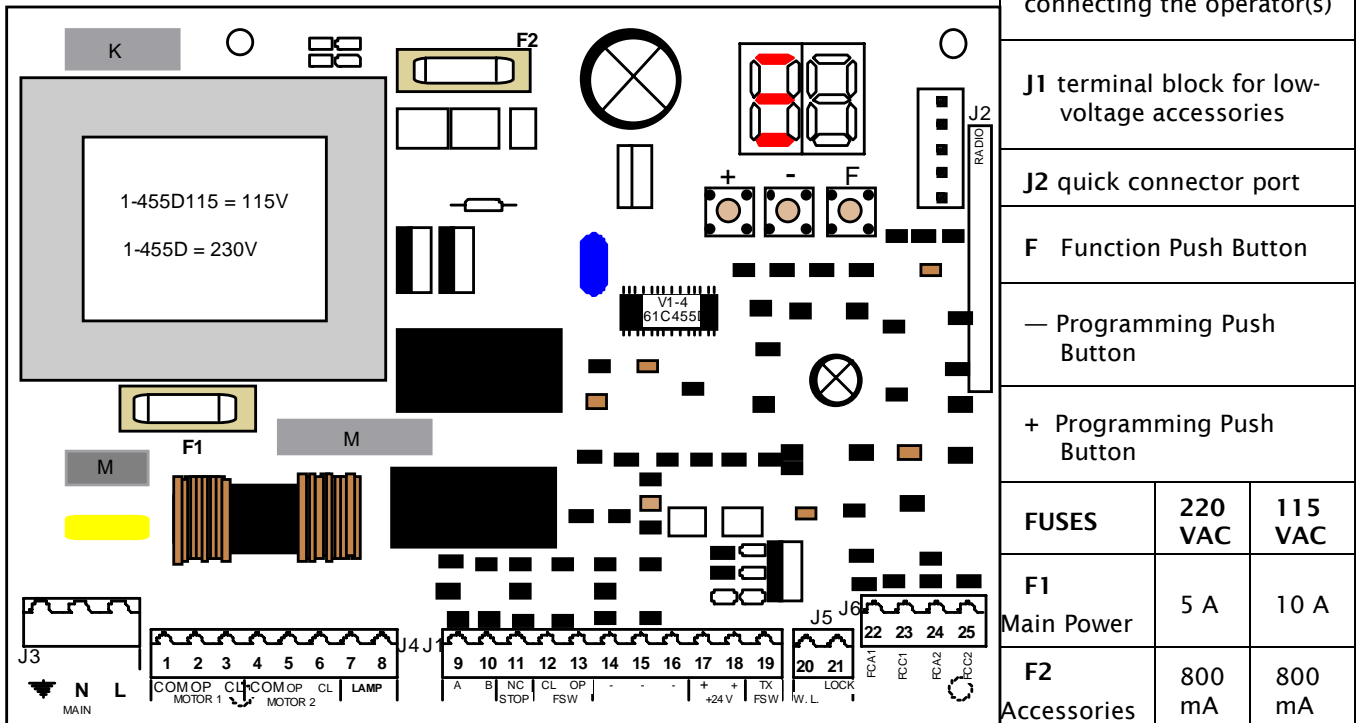

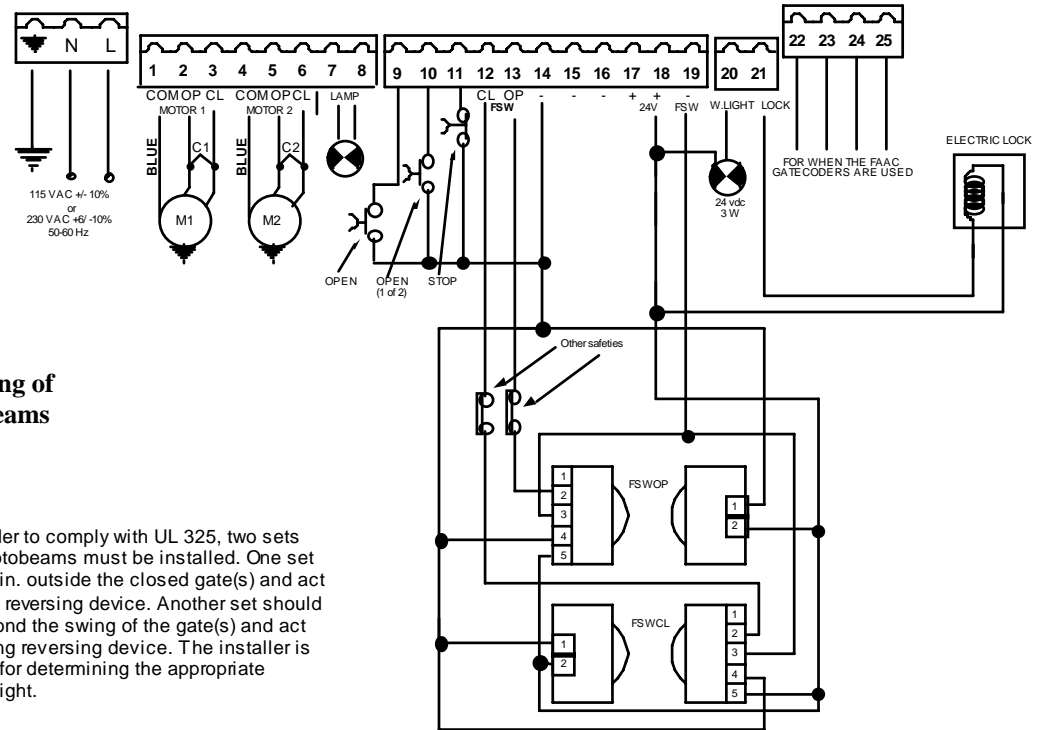

Figure 2-CP.
The terminal strip wiring of
the 455 D with photobeams

NOTE: In order to comply with UL 325, two sets of FAAC photobeams must be installed. One set should be 6 in. outside the closed gate(s) and act as a closing reversing device. Another set should be 6 in. beyond the swing of the gate(s) and act as an opening reversing device. The installer is responsible for determining the appropriate mounting height.

You cannot check the motor's direction of rotation without these circuits (jumpers) or the accessories. When properly prepared for testing, the LEDs FSWOP, STOP, and FSWCL should be illuminated (see Figure 4-CP).

WARNING! Running the operator—even for testing purposes—without a connected reversing device is potentially dangerous. Do not place yourself within the path of the moving gate during your test.

Disengage the operator(s) with the Manual Release key (see operator installation manual), and open the gate by hand about halfway.

Next, engage the operator(s) with the Manual Release key so that you can check the rotation of the motor(s).

To activate the operator(s) momentarily short across terminals 9 and 14.

Turn on the main power and send an activating signal to the operator. The gate leaf (or leaves) should open. If a gate leaf closes, then you need to turn off the main power and reverse the connection of the red and black wires on terminal block J4 for the operator controlling that leaf. Then you need to recheck the rotation direction again.

After having completed your test of the motor's direction of rotation, replace any test circuits you installed (between terminals 11 and 16, between 12 and 19, and between 13 and 19) with the proper reversing and stop devices. The instructions for installing such accessories follow.

CONNECT OTHER DEVICES

WARNING! Turn the main power off before you make any electrical connections.

POWER SUPPLY FOR ACCESSORIES: You can access a 24 VDC output for supplying power to accessories through terminals 17 or 18, (+) and 14 or 15 or 16, (-) on terminal block J1. In most cases, this source can be used to power 24 VDC accessories.

NOTE: The 455 D control panel allows a maximum accessory load of 800 mA.

REVERSING DEVICES: Reversing devices include photocells, inductive loops, and so forth. All of the reversing devices should have contacts of the normally closed (N.C.) type. Where you connect a device depends on whether you want the device to operate during opening or during closing.

NOTE: UL **does not** recognize the FAAC system with loop detectors or safety edges. FAAC photobeams must be used to comply with UL 325.

To wire photobeams, refer to Figure 2-CP (see FSWOP for opening photobeams, and FSWCL for closing photobeams). Photobeams must be connected as shown. See Figure 5-CP for the wiring of inductive loops. If using more than one reversing device, they must be wired in series.

(a) To the U. L. Listed gate operator

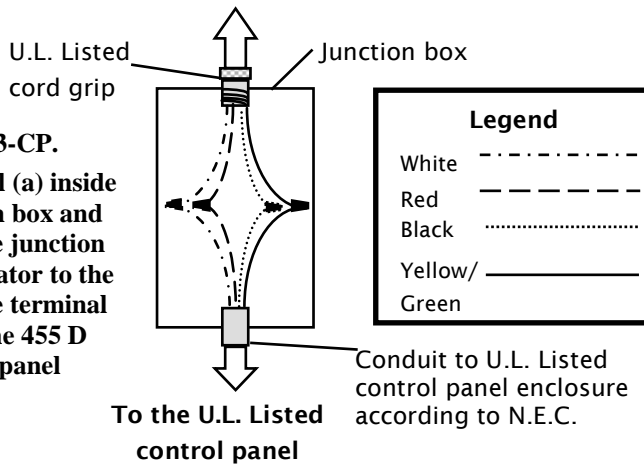

(b) U.L. Listed Control Panel Enclosure

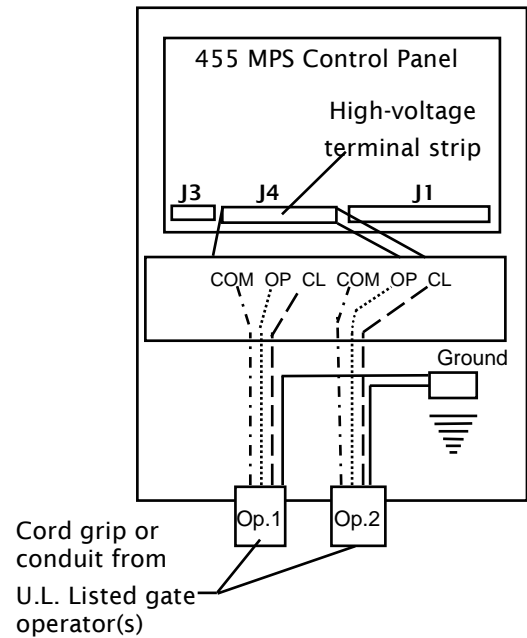

ACTIVATING DEVICES AND RADIO RECEIVER: The activating devices and radio receiver for your gate must have normally open (N.O.) contacts. Connect such devices to terminals 9 and 14.

NOTE: The FAAC radio receiver plugs into the 5 prongs labeled J2 (Quick connect port).

Figure 5-CP shows how to connect a three or four wire receiver.

DECODER CARD: If you are installing the Digicard magnetic card reader, or the Digikey keyboard, use the quick-fit connector J2 for the DS decoder card (see Figure 1-CP).

NOTE: If your using both a receiver and decoder, hard wire the decoder and plug in the receiver.

OPEN/HOLD OPEN DEVICE: To open and hold open the gate, simply maintain a contact across terminals 9 and 14. ("A" Mode only)

STOP BUTTON: The stop button you install must have normally closed (N.C.) contacts. Multiple stop buttons must be wired in series. Connect your stop device between terminals 11 and 16.

NOTE: The 455 will not operate the motors without a closed circuit between 11 & 16.

The LED Indicators: The nine light emitting diodes (LEDs) on the control panel can be used to check for the proper function of the devices attached to the panel. The LED lights are on whenever the contacts are closed across each of the respective terminals.

OP_A and OP_B (Partial Opening) should illuminate only when an activating signal is sent for 2 and 1 gate leaves, respectively. STOP should be illuminated except when the stop button is pressed. FSWOP and FSWCL should be illuminated except when the reversing

LED	On	Off
OP_A	Command Given	No Command
OP_B	Command Given	No Command
Stop	No Command	Command Given
FSW Open	Opening reversing devices clear	Reversing device triggered
FSW Close	Closing reversing devices clear	Reversing device triggered
FCA1 FCC1	Flashes when gate coder is in use. Operator 1	
FCA 2 FCC 2	Flashes when gate coder is in use. Operator 2	

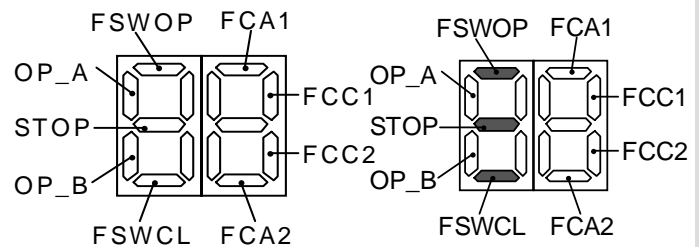

This display shows the meaning of each LED.

This display shows the normal status of the control panel.

Figure 4-CP. The 455 D display.

devices for opening and closing, safeties are triggered. Use the LEDs and the table in Figure 4-CP to determine if the accessory devices you have installed are operating properly.

Electric Locks: An electric lock can be wired to the 455 D in terminals 18 and 21 (12Vac pulsed provided). If a reversing stroke is needed to allow the electric lock to release, this must be done in advanced programming.

See Figure 5-CP for the connections for a magnetic locking device.

WARNING LIGHT: Connect a warning light to terminals 18 and 20 in the group labeled *W.LIGHT* in terminal block J1 and J5. The terminals provide an output voltage of 24 VDC, maximum power 3 Watts. This output voltage will power most 24 VDC warning lights.

NOTE: The behavior of the warning light varies according to the logic you have set.

LOGICS A, S, E, EP, AND B: The warning light is on steadily during opening and the pause phase. During closing, the light flashes.

LOGIC C: The warning light is on steadily during opening and flashes during closing.

SET OTHER OPERATING CONTROLS

WARNING! Turn the main power off before you make any electrical connections.

You need to program the control panel for your gate's operation. The 455 D Control Panel has on board programming that controls a wide range of functions.

OPERATING LOGICS

NOTE: The 455 D Control Panel provides inputs for opening reversing devices and closing reversing devices. FAAC strongly recommends the use of reversing devices, such as photocells or other non-contact sensors.

- **A (automatic):** The gate opens on command and automatically closes after a pause phase. A second command while opening is ignored; a second command during the pause phase interrupts the pause time; a second command during closing reopens the gate. A maintained open command will hold the gate open.
- **S (security):** The security mode is like A logic except that a second command during opening immediately closes the gate. A maintained open command will not hold the gate open.

- **E (semi-automatic):** This mode requires a command to open and a command to close. A second command during opening stops the gate. A second command during closing reopens the gate.
- **EP (semi-automatic, step by step):** This mode requires a command to open and a command to close. A second command during opening or closing causes the gate to stop. A third command then reverses the previous motion of the gate.
- **B (manned, pulsed):** This mode is designed for guard station use and requires a three-button switch (pulsed) to open, close, and stop the gate.
- **C (manned and constant):** This mode requires constant pressure switches. One to open and one to close. No pressure on a switch stops the gate.

The three programming push buttons allow the programming of the torque (or pressure), the pause time between opening and closing, and the leaf delay on closing.

WARNING! Turn the main power off before you make any electrical connections.

For all FAAC hydraulic operators using the 455 D control panel, the force **must** be set at its maximum setting of 50 in order to supply the correct voltage to the operator.

PAUSE TIME: The pause time between opening and closing can be adjusted from 0 seconds to 4 minutes. Time is adjusted in one-second increments from 0—59 seconds. When 60 seconds is reached, time is adjusted in 10 second increments up to 4 minutes. i.e. if display shows 2.5, it means 2 minutes and 50 seconds.

LEAF DELAY: You may choose to delay one leaf on closing for overlapping gate leaves. Be sure the operator on the leaf for delayed closing is connected to Motor 1. On opening, the leaf connected to Motor 2 is delayed 2.5 sec.

NOTE: If an opening leaf delay is desired, it must be enabled in the Advance Programming. However, if enabled, you cannot *adjust* this opening delay of the operator connected to Motor 2.

The closing leaf-delay time is adjustable from 0 to 4 minutes.

NOTE: If the opening/closing time is set at less than the leaf delay time, the delayed leaf closes at the end of the closing time.

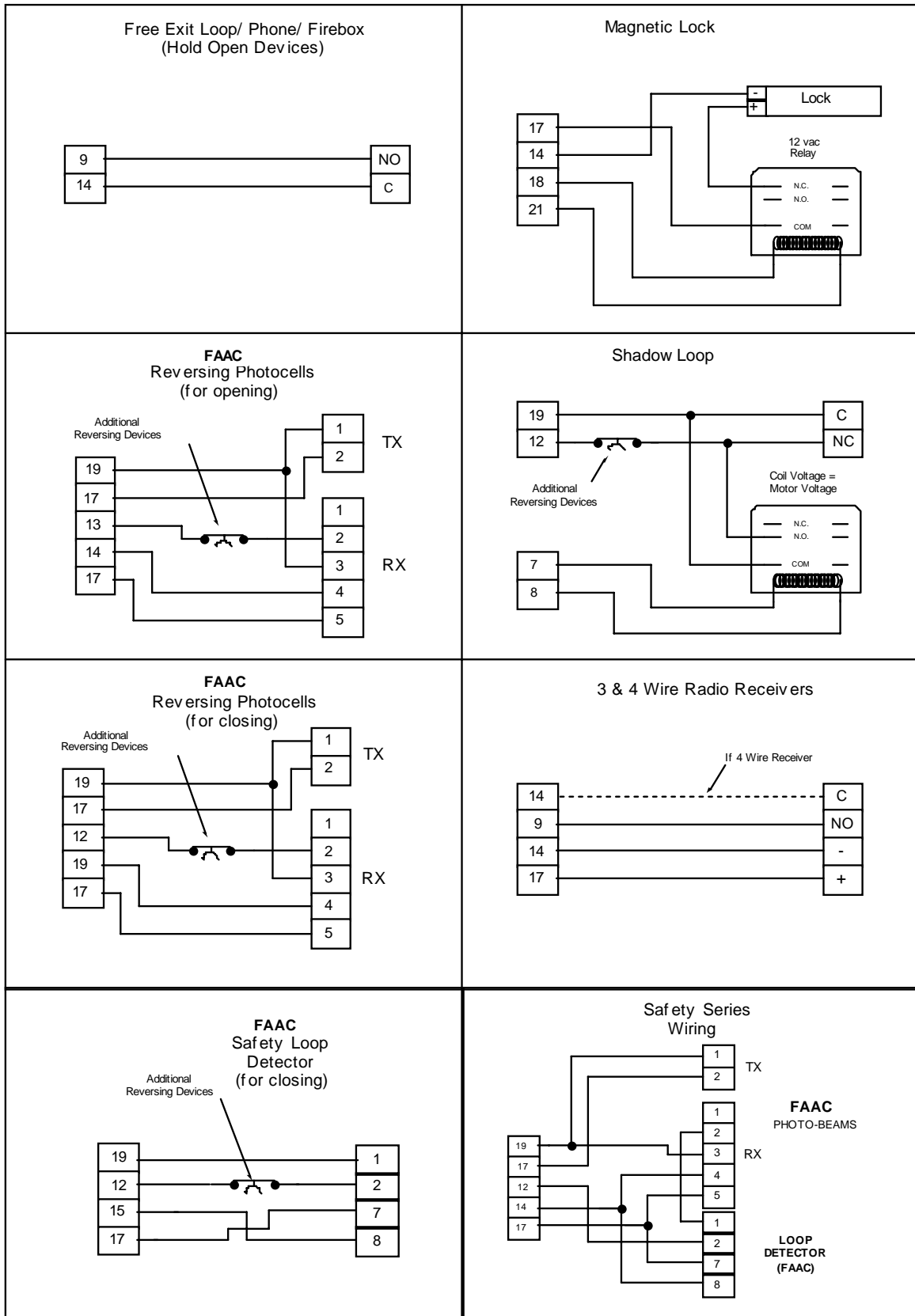

NO = Normally Open, NC = Normally Closed, C = Common, TX = Transmitter, RX = Receiver

Figure 5-CP. Common Accessories wired to 455 D Control Panel

PROGRAMMING

To program the automated system, the "Programming Mode" must be accessed.

Programming is split into two parts: BASIC and ADVANCED.

BASIC PROGRAMMING

To access BASIC PROGRAMMING, press the "F" key.

- If you press it (and hold it down), the display shows the name of the first function.
- If you release the key, the display shows the value of the function that can be modified with keys + and - .
- If you press and hold down the "F" key again (and hold it down), the display shows the name of the next function, etc.
- When you reach the last function, press "F" to exit the program, and the display resumes showing the status of the inputs.

The table on the right shows the sequence of functions accessible in BASIC PROGRAMMING.



ADVANCED PROGRAMMING

To access ADVANCED PROGRAMMING, press the "F" key and, as you hold it down, press the "+" key:



- If you release the "+", the display indicates the name of the first function.
- If you release the "F" key, too, the display shows the value of the function that can be modified with keys "+" and "-".
- If you press the "F" key (and hold it down), the display shows the name of the next function, and if you release it, the value that can be modified with keys "+" and "-".
- When you reach the last function, press the "F" key to exit the program, and the display resumes showing the status of the inputs.

The table on page 27 shows the sequence of functions accessible in ADVANCED PROGRAMMING

PROGRAM BUTTONS		
+	-	F
LEFT	MIDDLE	RIGHT

BASIC PROGRAMMING		
		
Display	Function	Default
LO	OPERATING LOGICS A = Automatic (Timer to Close) E = Semi Automatic S = Security EP = (Semi-Automatic) Step by Step B = Manned, Pulsed C = Manned, constant	E
PA	PAUSE TIME This is the time between open and closing and is adjustable from 0 to 4 min. This is only true in "A" Mode. (see pause time description)	0
F1	FORCE/TORQUE MOTOR 1 This adjusts the force / torque that motor 1 is applying to the gate leaf. Setting is 0 to 50.*	25
F2	FORCE/TORQUE MOTOR 2 This adjusts the force / torque that motor 2 is applying to the gate leaf. Setting is 0 to 50.*	25
cd	CLOSING LEAF DELAY Delays the closing of operator wired into motor one outputs. Adjustable from 0 to 4 minutes (Same as pause time)	0
LL	MOTOR RUN TIME This enables where you choose from "simple" learning or "complete" learning of the motor run time. See page 10 & 11 for complete details. Simple Learning  ≈ 1 s. Complete Learning  > 3 s.	
In	EXIT PROGRAMMING Exit from programming and return to display of inputs status.	

* With Hydraulic operators the Force/Torque must be set to the maximum setting of 50.

ADVANCED PROGRAMMING		
 + 		
Display	Function	Default
bo	MAXIMUM TORQUE AT INITIAL THRUST: The motors operate at maximum torque (ignoring the torque setting) at start of movement. Useful for heavy leaves. Y = Enable No = Disabled	no
cs	LAST STROKE AT CLOSING: The motors are activated at full speed for 1s to facilitate locking of the electric lock. Y = Enable No = Disabled	no
rs	REVERSING STROKE: Before opening, while the gate is closed, the motors thrust to close for 2 s thus facilitating release of the electric lock. Y = Enable No = Disabled	no
od	LEAF 2 OPENING DELAY (2s): Enables delayed start of leaf 2, avoiding interference between leaves. Y = Enable No = Disabled	no
fs	FAIL SAFE: If this function is activated, it enables a function test of the photocells before any gate movement. Y = Enable No = Disabled	no
pf	PRE FLASHING (5s): 5s before start of movement. Y = Enable No = Disabled	no
el	ELECTRIC LOCK ON LEAF 2: For using the electric lock on leaf 2 instead of on leaf 1. Y = Enable No = Disabled	no

ph	INDICATOR-LICHT: If 0 is selected, the output functions as a standard indicator-light (lit at opening and pause, flashing at closing, and off when gate closed). Time can be adjusted from 0 to 59s in 1s increments, and from 1.0 to 4.1 min. in 10s steps. 0 = Standard Indicator-Light From 1 to 4.1 = Timed Output	0
rd	CLOSING PHOTOCELLS REVERSE AT RELEASE: Enable this function if you want the closing photocells to stop the gate and reverse it after the beam is cleared. Default setting is immediate reverse. Y = Enable No = Disabled	no
sp	A.D.M.A.P. FUNCTION: If this function is enabled, the safety devices to comply with French standard NFP 25/362. Y = Enable No = Disabled	no
rs	ASSISTANCE REQUEST (COMBINED WITH NEXT FUNCTION): If activated, at the end of countdown (settable with the next function, i.e. "Cycle programming") it effects 8s of pre-flashing at every Open pulse (job request). Can be useful for setting scheduled maintenance jobs. Y = Enable No = Disabled	no
nc	CYCLE PROGRAMMING: For setting count down of system operation cycles. Settable (in thousands) from 0 to 99 thousand cycles. The displayed value is updated as cycles proceed. This function can be used to check use of the board or to exploit the "Assistance Request" function.	0
et	EXTRA WORK TIME: When operating, if reversing occurs, and if the leaf does not reach its end contact point, you can activate this function to increase work time. Y = ACTIVE NO = DISABLED	no
in	EXIT PROGRAMMING: Exit from programming.	

LEARNING OF OPERATING TIMES

WARNING: During the learning procedure, the safety devices are disabled! Therefore, any and all traffic must be avoided in the path of the gate leaf(s).

NOTE: Programming must start with the gate(s) in the closed position.

Opening/closing time is established by the learning procedure which varies slightly according to whether you are or are not using Gatecoders.

LEARNING OF NORMAL TIMES

Normal learning (i.e. without Gatecoders) can be done in two different ways:

SIMPLE LEARNING (WITHOUT SLOW DOWN)

Close the gates, enter "BASIC PROGRAMMING", select the TIME LEARNING function and press the + push-button for 1 second the display begins flashing and the leaves begin the opening movement.

Wait for the leaves to reach the opening positive stop and then supply an OPEN A command after the desired motor run time has been reached (by push-button or radio control) to stop the movement: the leaves stop and the display stops flashing. One more command given will close the gate.

The procedure has ended and the gate is ready to operate.

COMPLETE LEARNING (WITH SLOW DOWN)

NOTES:

- If you do not wish to slow the gate operator(s) down, wait for the gate to reach its positive stop and supply two (2) consecutive open commands (within 1 second).
- If only one gate operator (1) is used, you must go through the entire programming procedure, as if you were programming for two gate operators (2). When the operator has finished opening, supply 5 open commands until the gate operator begins to close, and then resume normal operations.

Close the gates, enter "BASIC PROGRAMMING", select the TIME LEARNING function and press the + push-button until the gate starts movement: the display will be flashing. The following functions can be commanded by the OPEN A (by push-button wired to terminals 9

and 14, or radio control):

- When gate operator (1) reaches the position that you want it to slow down, an open command must be given to start the slow down phase.
- When gate operator (1) reaches the positive stop and the desired motor run time has been reached, an open command must be given to shut the motor off. At this point gate operator (2) will automatically start to open.
- When gate operator (2) reaches the position that you want it to slow down, an open command must be given to start the slow down phase.
- When gate operator (2) reaches the positive stop and the desired motor run time has been reached, an open command must be given to shut the motor off. At this point gate operator (2) will automatically start to close.
- When gate operator (2) reaches the position that you want it to slow down, an open command must be given to start the slow down phase.
- When gate operator (2) reaches the positive stop and the desired motor run time has been reached, an open command must be given to shut the motor off. At this point gate operator (1) will automatically start to close.
- When gate operator (1) reaches the position that you want it to slow down, an open command must be given to start the slow down phase.
- When gate operator (1) reaches the positive stop and the desired motor run time has been reached, an open command must be given to shut the motor off.

The display stops flashing and the gate is ready for normal operation.

LEARNING TIMES WITH GATECODER

Learning with the Gatecoder can be done in two different ways:

SIMPLE LEARNING

Close the gates, enter "Basic Programming", select the TIME LEARNING function and press the + push-button for 1 second: the display begins flashing and the leaves begin the opening movement.

The movement stops automatically when the opening positive stop is reached and the display stops flashing.

The procedure has ended and the gate is ready to operate, using default slow down automatically set by the control panel.

COMPLETE LEARNING

NOTES:

- If only one gate operator (1) is used, you must go through the entire programming procedure, as if you were programming a gate operator (2). When the gate operator (1) has finished opening, supply 5 open commands until the gate operator begins to close, and then resume normal operations.

Close the gates, enter "BASIC PROGRAMMING", select the TIME LEARNING function and press the + push-button until the gate starts movement: the display will be flashing. The following functions can be commanded by the OPEN A command (by radio control or key push-button):

- When gate operator (1) reaches the position that you want it to slow down, an open command must be given to start the slow down phase. When the gate operator reaches its positive stop, the operator will automatically shut off.
- An open command must be given to start opening gate operator (2).
- When gate operator (2) reaches the position that you want it to slow down, an open command must be given to start the slow down phase. When the gate operator reaches its positive stop, the operator will automatically shut off.
- An open command must be given to start closing gate operator (2).

- When gate operator (2) reaches the position that you want it to slow down, an open command must be given to start the slow down phase. When the gate operator reaches its positive stop, the operator will automatically shut off.
- An open command must be given to start closing gate operator (1).
- When gate operator (1) reaches the position that you want it to slow down, an open command must be given to start the slow down phase. When the gate operator reaches its positive stop, the operator will automatically shut off.

The display stops flashing and the gate is ready for normal operation.

NOTES:

- The open command to slow down the gate should be given before the gate reaches the positive stop to prevent the gate from hitting the stop at full speed. The positive stop could be mistaken for an obstacle and then upon hitting it, the gate(s) would automatically reverse on contact.

AUTOMATED SYSTEM TEST

When you have finished programming, check if the system is operating correctly.

Most important of all, check that the force is adequately adjusted and that the safety devices are operating correctly.

If pressure adjustments on hydraulic operators are not set before programming. It may need to be reprogrammed for desired results.

A (Automatic) Logic (455 D)

Gate Status	Open A	Open B	Stop	Opening Reversing Device(s)	Closing Reversing Device(s)	Warning Light
Closed	Opens both leaves and closes them after pause time	Opens single leaf connected to Motor 1 and closes it after pause time	No effect	No effect	No effect	Off
Opening	No effect	No effect	Stops	Stops; gate closes when reversing device no longer triggered	No effect	On
Opened	Interrupts the pause time	Interrupts the pause time	Stops	No effect	Gate remains open until reversing devices no longer triggered	On
Closing	Opens both leaves	Opens leaf	Stops	No effect	Depends on DIP switch 4	Flashes
Stopped	Closes the leaves	Closes the leaf	No effect (opening is inhibited)	No effect	No effect (opening is inhibited)	On

S (Security) Logic (455 D)

Gate Status	Open A	Open B	Stop	Opening Reversing Device(s)	Closing Reversing Device(s)	Warning Light
Closed	Opens both leaves and closes them after pause time	Opens single leaf connected to Motor 1 and closes it after pause time	No effect	No effect	No effect	Off
Opening	Closes both leaves	Closes leaf	Stops	Stops; gate closes when reversing device no longer triggered	No effect	On
Opened	Closes both leaves	Closes leaf	Stops	No effect	Gate remains open until reversing devices no longer triggered	On
Closing	Opens both leave	Opens leaf	Stops	No effect	Depends on DIP switch 4	Flashes
Stopped	Closes the leaves	Closes the leaf	No effect (opening is inhibited)	No effect	No effect (opening is inhibited)	On

B (Manned, Pulsed) Logic (455 D)

Gate Status	Open A	Open B	Stop	Opening Reversing Device(s)	Closing Reversing Device(s)	Warning Light
Closed	Opens 1 or both leaves	No effect	No effect	No effect	No effect	Off
Opening	No effect	No effect	Stops	No effect	Stops	On
Opened	No effect	Closes 1 or both leaves	No effect	No effect	No effect	On
Closing	No effect	No effect	Stops	Stops	No effect	Flashes
Stopped	Opens 1 or both leaves	Closes 1 or both leaves	No effect	No effect	No effect	On

E (Semi-automatic) Logic (455 D)

Gate Status	Open A	Open B	Stop	Opening Reversing Device(s)	Closing Reversing Device(s)	Warning Light
Closed	Opens both leaves	Opens single leaf connected to Motor 1	No effect	No effect	No effect	Off
Opening	Stops	Stops	Stops	Stops; gate closes when reversing device no longer triggered	No effect	On
Opened	Closes both leaves	Closes leaf	Stops	No effect	No effect (opening is inhibited)	On
Closing	Closes both leaves	Closes leaf	Stops	No effect (opening is inhibited)	Depends on DIP switch 4	Flashes
Stopped	Closes the leaves	Closes the leaf	No effect (opening is inhibited)	No effect	No effect (opening is inhibited)	On

EP (Semi-automatic, Step by Step) Logic (455 D)

Gate Status	Open A	Open B	Stop	Opening Reversing Device(s)	Closing Reversing Device(s)	Warning Light
Closed	Opens both leaves	Opens single leaf connected to Motor 1	No effect (opening is inhibited)	No effect (opening is inhibited)	No effect (opening is inhibited)	Off
Opening	Stops	Stops	Stops	Stops; gate closes when reversing device no longer triggered	No effect	On
Opened	Closes both leaves	Closes leaf	Stops	No effect	No effect (opening is inhibited)	On
Closing	Stops	Stops	Stops	No effect (opening is inhibited)	Depends on DIP switch 4	Flashes
Stopped	Gate leaves reverse direction	Gate leaf reverses direction	No effect (opening is inhibited)	No effect (opening is inhibited)	No effect (opening is inhibited)	On

C (Manned and Constant) Logic (455 D)

Gate Status	Open A	Open B	Stop	Opening Reversing Device(s)	Closing Reversing Devices(s)	Warning Light
Closed	Opens 1 or both leaves	No effect	No effect	No effect	No effect	Off
Opening	No effect	No effect	Stops	No effect	Stops	On
Opened	No effect	Closes 1 or both leaves	No effect	No effect	No effect	On
Closing	No effect	No effect	Stops	Stops	No effect	Flashes
Stopped	Opens 1 or both leaves	Closes 1 or both leaves	No effect	No effect	No effect	On

MAINTENANCE

THE 760 OPERATOR

The FAAC recommended maintenance schedule varies according to the frequency of use of the operators, whether lightly used operators (once or twice an hour) or heavily used operators (many cycles per hour). Operators used in a humid/ salt air climate should follow the heavy duty use schedule.

Check the oil.

To check the oil level correctly, remove the oil filler cap on the 760 Operator. The oil level should be at or just below the opening of the filler hole with it attached to the load bearing box.

Light duty use: check once per year
Heavy duty use: check every 6 mo

Change the oil.

Changing the oil completely in the hydraulic system of the 760 Operator requires removing the 760 Operator from its installed position. (Do not remove the gate or the mounting box with the pinion and splined shaft.) Drain the oil out the oil filler hole before filling the operator to just below the hole. Remount the operator.

Light duty use: change every 4 yr
Heavy duty use: change every 2 yr

Check the pressure settings.

Light duty use: check once per year
Heavy duty use: check every 6 mo

Rack and Pinion

When you remove the 760 Operator from the mounting box to change the hydraulic oil, grease the rack and the pinion.

Light duty use: every 4 yr
Heavy duty use: every 2 yr

Bleed the Hydraulic System

The 760 Operator has had all air bled from its hydraulic system when it is shipped to you. The only time it should be necessary to bleed the 760 Operator is after you repair or move the hydraulic system.

To bleed the hydraulic system of air that might cause bouncy or jerky operation do the following:

1. Remove the access cover to the mounting box.
2. Give an open signal to the gate.
3. While the gate is opening unscrew the opening bleed screw (see Figure 19 on page 13).
4. Wait until only clean, bubble-free oil flows out the bleed screw.
5. Tighten the opening bleed screw.
6. Give a closing signal to the gate.
7. While the gate is closing, unscrew the closing bleed screw.
8. Wait until only clean, bubble-free oil flows out the bleed screw.
9. Tighten the closing bleed screw.

Repeat steps 1-8 again after five minutes if necessary. Then be sure to slowly fill the oil level to just below the filler hole.

THE 455 D CONTROL PANEL

Keep the control panel free from spider webs, insects, etc. Otherwise, the control panel requires no maintenance.

SAFETY IN GATE DESIGN

- A gate is a potential traffic hazard, so it is important that you locate the gate far enough away from the road to eliminate the potential of traffic getting backed up. This distance is affected by the size of the gate, how often it is used, and how fast the gate operates.
- The operator you choose to install on your gate must be designed for the type and size of your gate and for the frequency with which you use the operator.
- Your gate must be properly installed and must work freely in both directions *before* the automatic operator is installed.
- An automatic operator should be installed on the inside of the property/fence line. Do not install the operator on the public side of the property/fence line.
- Outward swinging gates with automatic operators should not open into a public area.
- Pedestrians should not use a vehicular gate system. Prevent such inappropriate use by installing separate gates for pedestrians.
- The operating controls for an automatic gate must be secured to prevent the unauthorized use of those controls.
- The controls for an automatic gate should be located far enough from the gate so that a user cannot accidentally touch the gate when operating the controls.
- Exposed, reachable pinch points on a gate are potentially hazardous and must be eliminated or guarded.
- It is extremely unsafe to compensate for a damaged gate by over tightening a clutch or increasing hydraulic pressure.
- An automatic gate operator should not be installed on a gate if people can reach or extend their arms or legs through the gate. Such gates should be guarded or screened to prevent such access.

TROUBLESHOOTING

WARNING! Before you do any work on the control panel, be sure to turn off the main power.

NOTE: Any control panel specific information in the following applies to the 455 D control panel only.

PROBLEM: THE GATE DOES NOT RESPOND TO AN ACTIVATING SIGNAL.

SOLUTION: You should have at least one operator wired to terminals 1, 2 and 3.

Be sure that you have the motor start capacitors wired in terminals 2 and 3, 5 and 6 with the directional leads.

Be sure that the torque/force setting is at the maximum setting of 50 in programming.

Verify that the LEDs FSWOP, FSWCL, and the STOP are illuminated. If they are not illuminated, be sure that you have closed circuits in the stop and reversing inputs.

Verify that your activating device works properly. OP_A should illuminate when you signal the gate to open. If OP_A does not illuminate when you signal the gate, then the problem may be in your activating device. Short across terminals 9 and 14. If the short causes the gate to open, then the problem is in the activating device. Repair or replace the device.

PROBLEM: THE GATE DOESN'T OPEN (OR CLOSE) THOUGH THE MOTORS ARE RUNNING.

SOLUTION: Make sure that the motor is running in the right direction, and make sure the Manual Release mechanism has fully engaged the hydraulic system.

Increase the bypass pressure in small 1/4 turn increments to see if the hydraulic system needs more pressure.

PROBLEM: THE GATE OPENS BUT DOES NOT CLOSE.

SOLUTION: Make sure you have selected the desired operating mode.

Verify that the reversing devices are working properly. FSWOP and FSWCL should be illuminated except when a reversing device is triggered. If either does not illuminate, then one of your reversing devices is preventing the gate from responding to your signal. Check your reversing devices.

If no reversing devices are installed, make sure a circuit is installed between appropriate terminals.

PROBLEM: THE GATE DOES NOT FULLY OPEN (OR CLOSE).

SOLUTION: Increase the bypass pressure(s) to see if the hydraulic system needs more pressure.

Check the operator's motor run time selection. You should program a time that is just longer than the rated speed of your model of operator. For example, because the 760 CBAC has a rated opening time of 17 seconds, you should program the time to be at least 20 or 25 seconds.

Check to see that there are no obstructions in the path of the gate or that the hinges are not binding.

PROBLEM: THE OPERATOR DOESN'T WORK SMOOTHLY AND THE GATE JERKS AS IT OPENS AND CLOSES.

SOLUTION: Check the oil level in the operator.

Make sure the Manual Release mechanism has fully engaged the hydraulic operation of the operator.

Bleed the air from the hydraulic system. (See page 32).

Make sure that a flexible gate leaf is not the problem. If the gate leaf flexes, then stiffen the gate or use a slower operator.

This page intentionally left blank.

LIMITED WARRANTY

To the original purchaser only: FAAC International, Inc., warrants, for twenty-four (24) months from the date of invoice, the gate operator systems and other related systems and equipment manufactured by FAAC S.p.A. and distributed by FAAC International, Inc., to be free from defects in material and workmanship under normal use and service for which it was intended *provided* it has been properly installed and operated. FAAC International, Inc.'s obligations under this warranty shall be limited to the repair or exchange of any part of parts manufactured by FAAC S.p.A. and distributed by FAAC International, Inc. Defective products must be returned to FAAC International, Inc., freight prepaid by purchaser, within the warranty period. Items returned will be repaired or replaced, at FAAC International, Inc.'s option, upon an examination of the product by FAAC International, Inc., which discloses, to the satisfaction of FAAC International, Inc., that the item is defective. FAAC International, Inc. will return the warranted item freight prepaid. The products manufactured by FAAC S.p.A. and distributed by FAAC International, Inc., are not warranted to meet the specific requirements, if any, of safety codes of any particular state, municipality, or other jurisdiction, and neither FAAC S.p.A. or FAAC International, Inc., assume any risk or liability whatsoever resulting from the use thereof, whether used singly or in combination with other machines or apparatus.

Any products and parts not manufactured by FAAC S.p.A. and distributed by FAAC International, Inc., will carry only the warranty, if any, of the manufacturer. This warranty shall not apply to any products or parts thereof which have been repaired or altered, without FAAC International, Inc.'s written consent, outside of FAAC International, Inc.'s workshop, or altered in any way so as, in the judgment of FAAC International, Inc., to affect adversely the stability or reliability of the product(s) or has been subject to misuse, negligence, or accident, or has not been operated in accordance with FAAC International, Inc.'s or FAAC S.p.A.'s instructions or has

been operated under conditions more severe than, or otherwise exceeding, those set forth in the specifications for such product(s). Neither FAAC S.p.A. or FAAC International, Inc., shall be liable for any loss or damage whatsoever resulting, directly or indirectly, from the use or loss of use of the product(s). Without limiting the foregoing, this exclusion from liability embraces a purchaser's expenses for downtime or for making up downtime, damages for which the purchaser may be liable to other persons, damages to property, and injury to or death of any persons. Neither FAAC S.p.A. or FAAC International, Inc., assumes nor authorizes any person to assume for them any other liability in connection with the sale or use of the products of FAAC S.p.A. or FAAC International, Inc. The warranty hereinabove set forth shall not be deemed to cover maintenance parts, including, but not limited to, hydraulic oil, filters, or the like. No agreement to replace or repair shall constitute an admission by FAAC S.p.A. or FAAC International, Inc., of any legal responsibility to effect such replacement, to make such repair, or otherwise. This limited warranty extends only to wholesale customers who buy directly through FAAC International, Inc.'s normal distribution channels. FAAC International, Inc., does not warrant its products to end consumers. Consumers must inquire from their selling dealer as to the nature and extent of that dealer's warranty, if any.

This warranty is expressly in lieu of all other warranties expressed or implied including the warranties of merchantability and fitness for use. This warranty shall not apply to products or any part thereof which have been subject to accident, negligence, alteration, abuse, or misuse or if damage was due to improper installation or use of improper power source, or if damage was caused by fire, flood, lightning, electrical power surge, explosion, wind storm, hail, aircraft or vehicles, vandalism, riot or civil commotion, or acts of God.