

# 950 BM

Swing Door Operator



**FAAC**

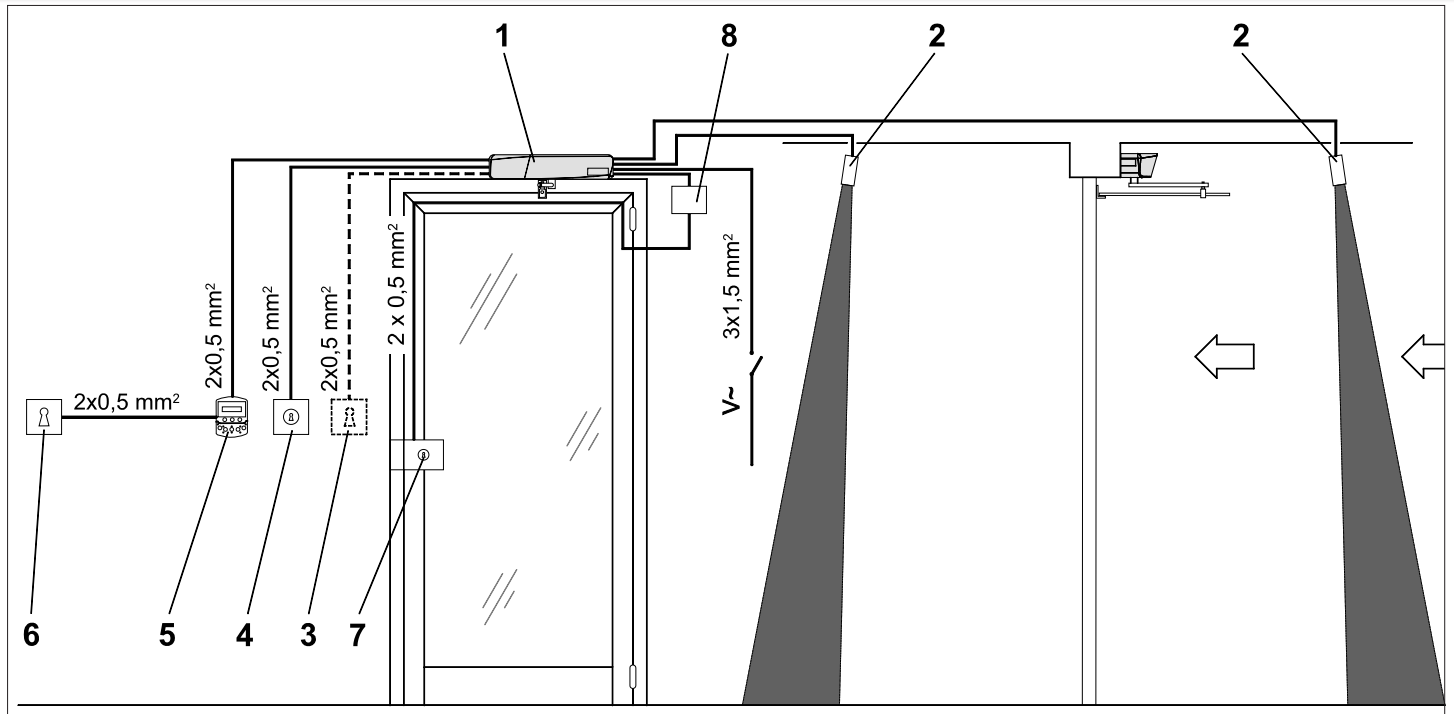


Fig. 2a

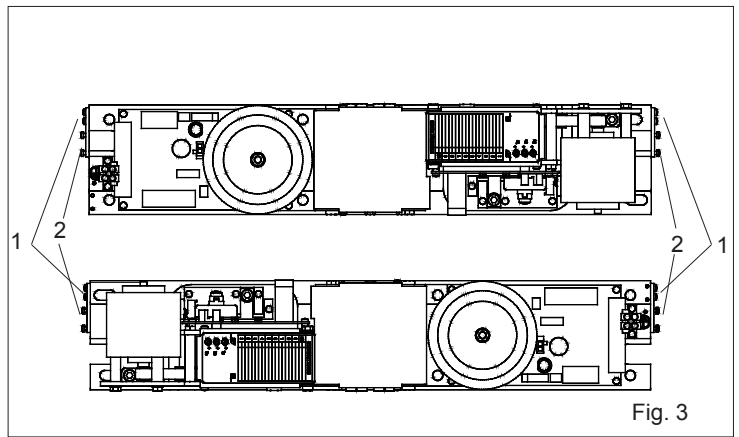


Fig. 3

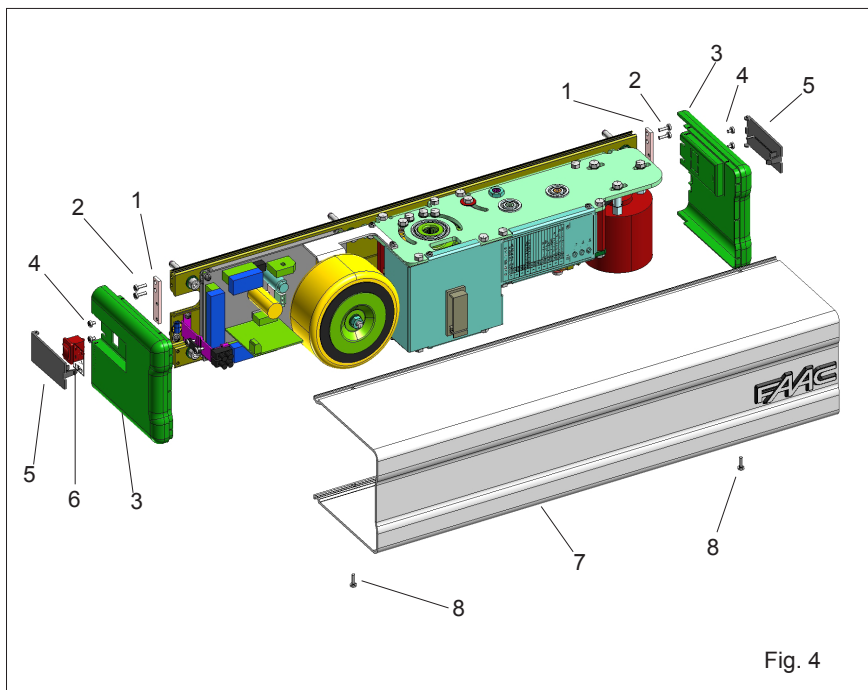


Fig. 4

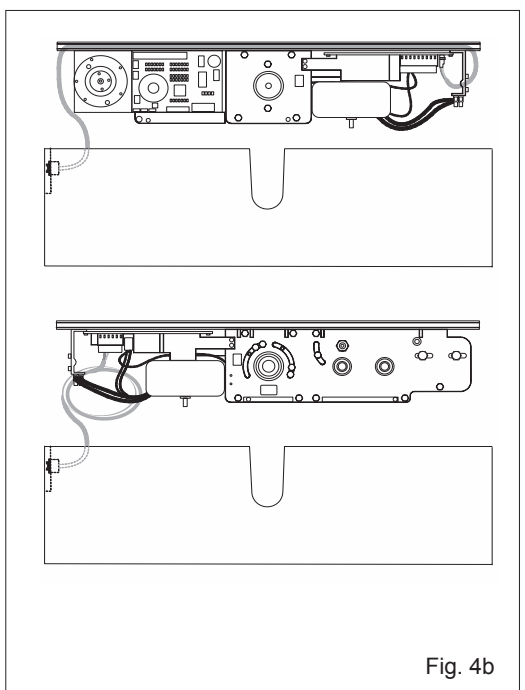


Fig. 4b

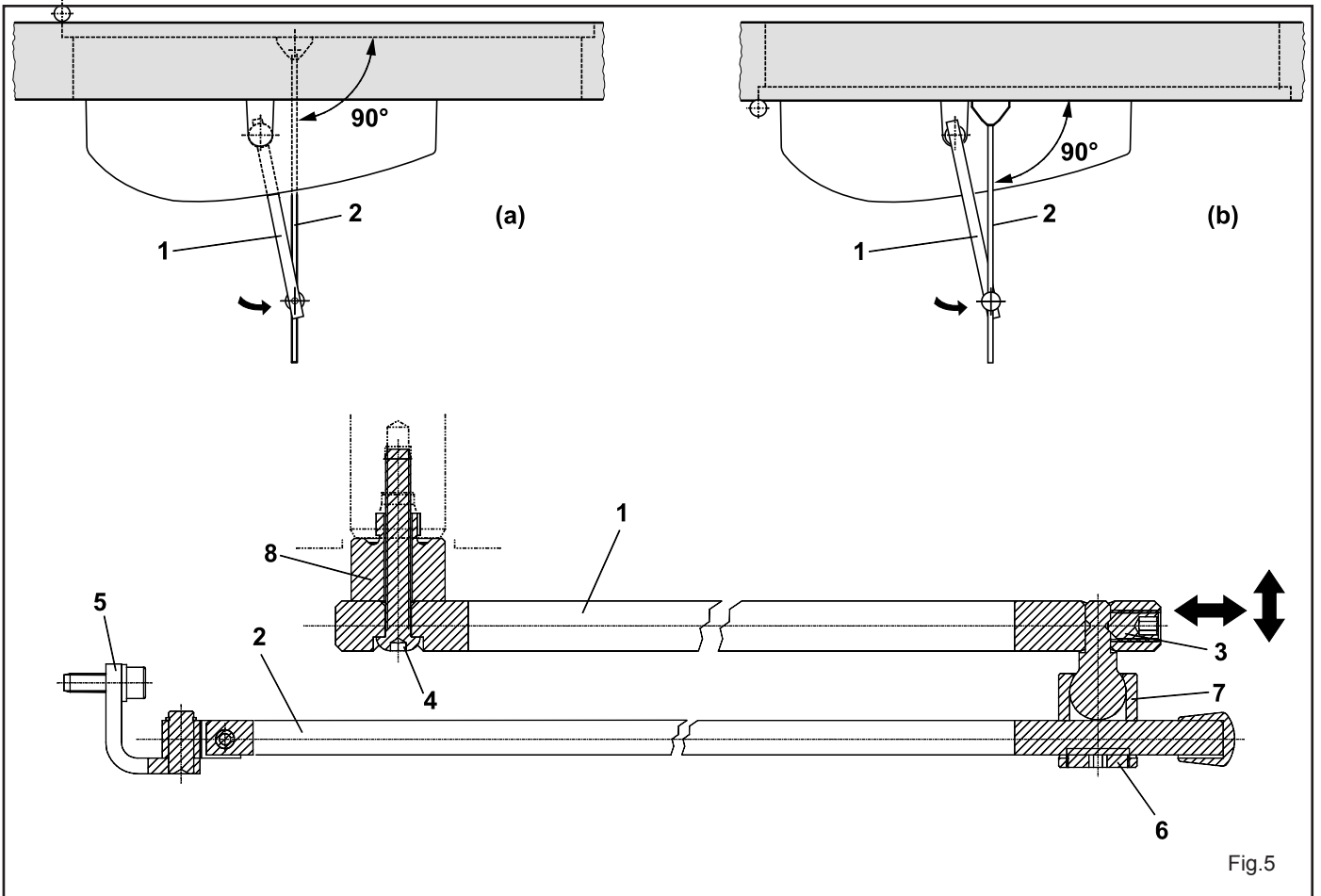


Fig.5

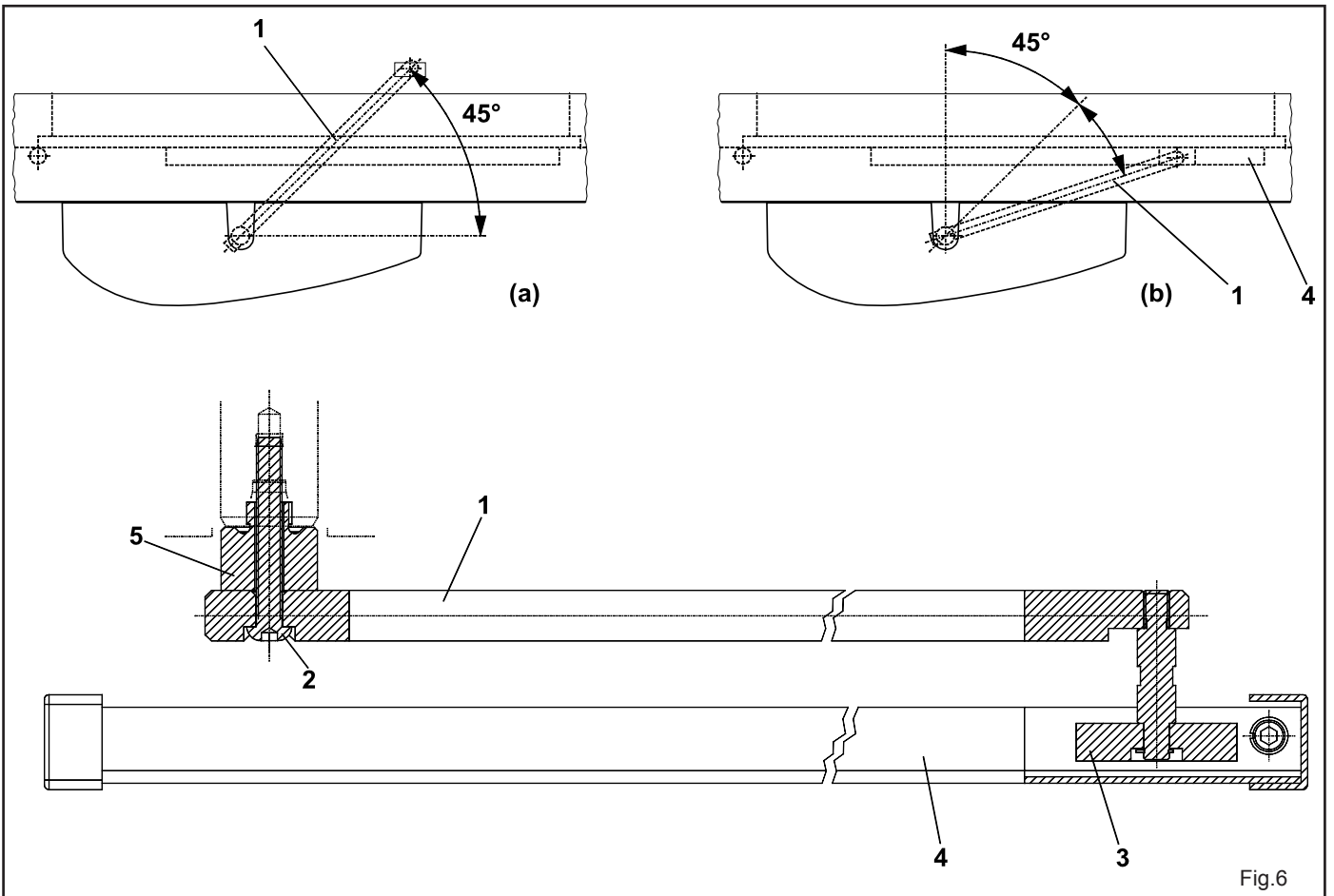
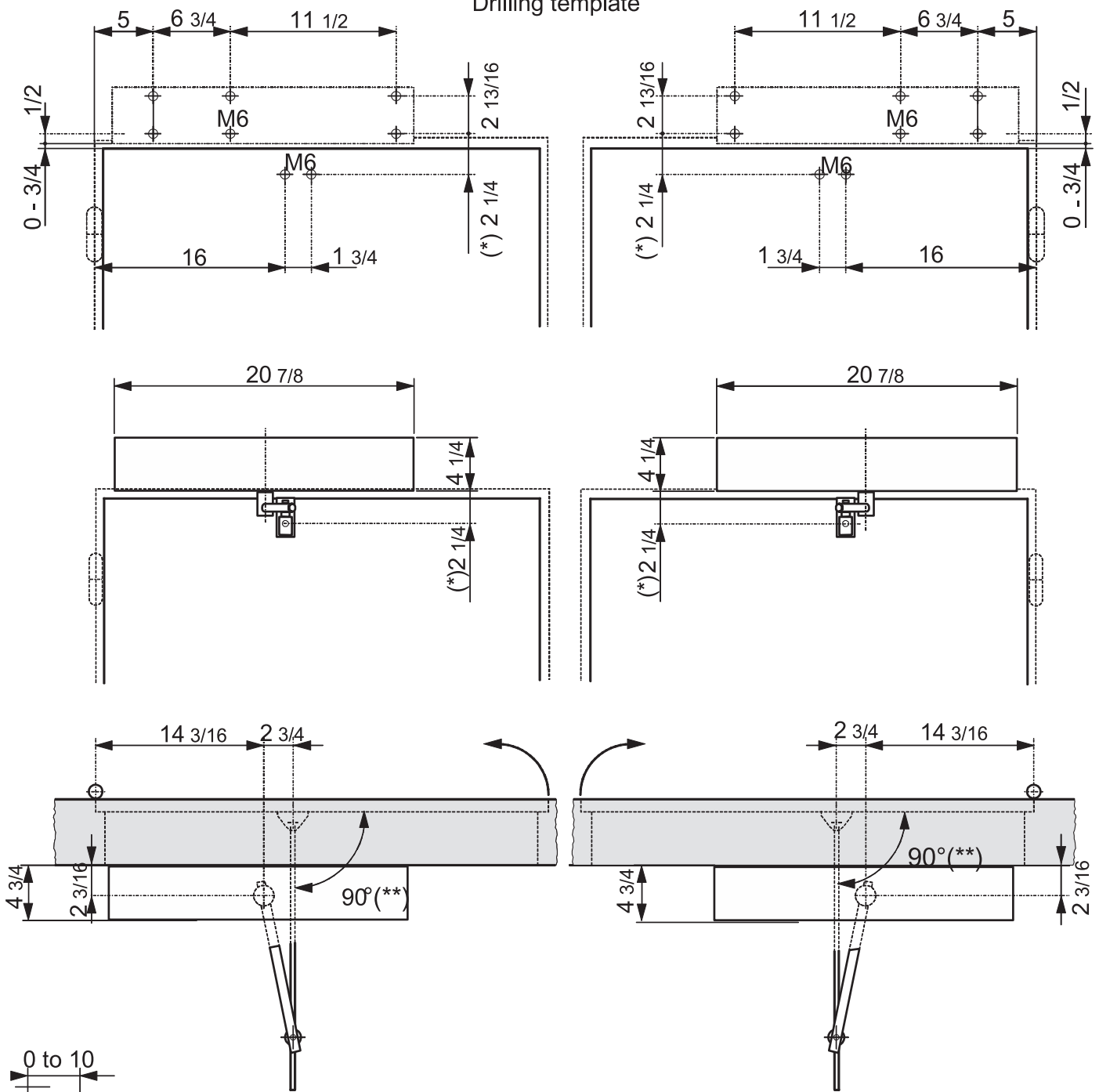


Fig.6

**TABLE A: LINTEL MOUNTING (PUSHING ARTICULATED ARM)**

Drilling template



(\* ) Distance with standard extension.  
If a greater distance between the operator and the arm is required, add the optional modular extensions.

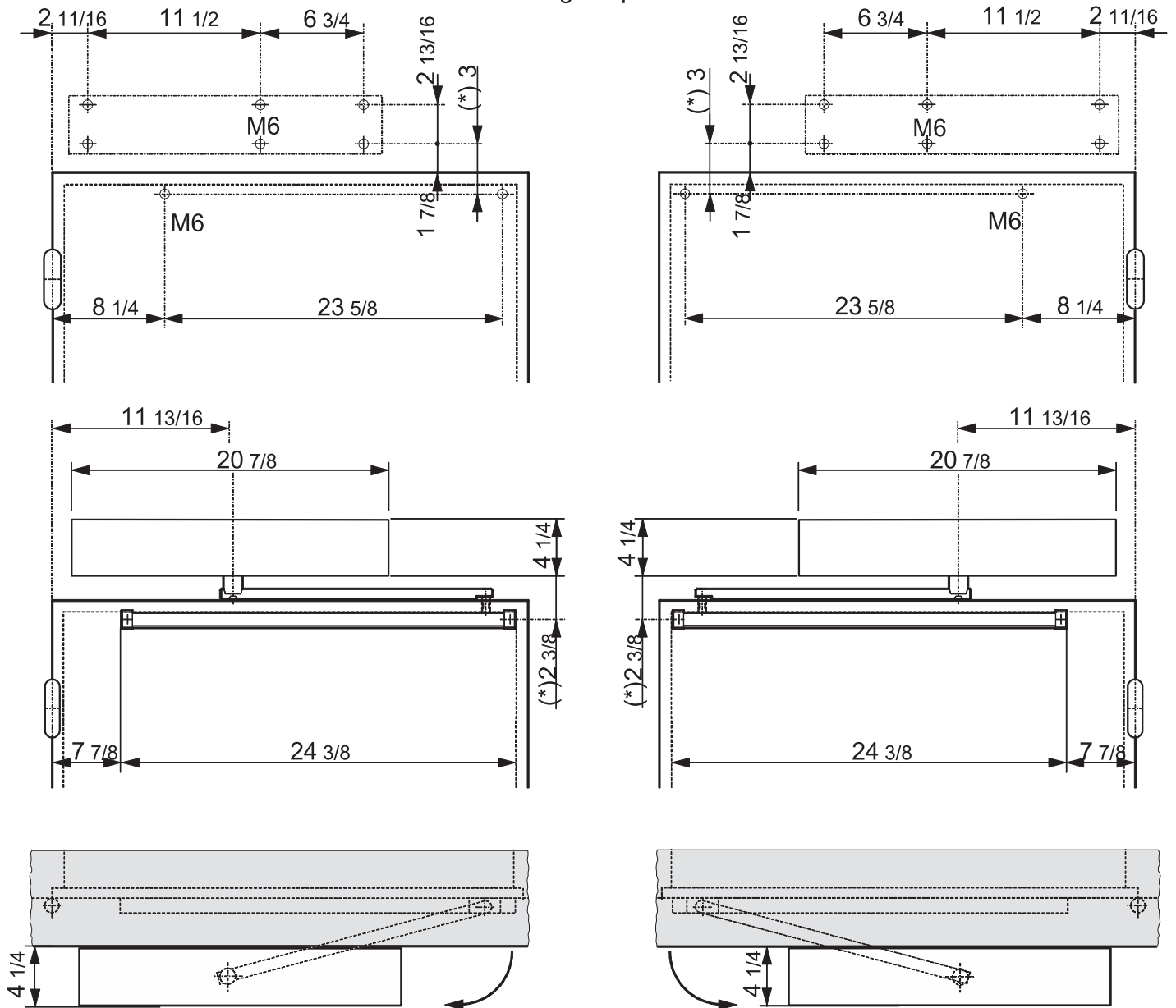
Each modular extension increases the standard height of 1 1/8 inches.

It is not recommended to use more than 2 extensions.

Dimensions in inches

**TABLE B: LINTEL MOUNTING (SLIDING ARM)**

Drilling template



(\* ) Distance with standard extension.  
If a greater distance between the operator and the arm is required, add the optional modular extensions.

Each modular extension increases the standard height of 1 1/8 inches.

It is not recommended to use more than 2 extensions.

Dimensions in inches

# 950 BM

The 950 BM is an electro-mechanical automated system for swing-leaf doors with direct current motor and return spring. It has an integrated microprocessor control unit with self-diagnosis and continuous verification of all door functions and an anti-crushing safety device active for both opening and closing.

The activation arms is in stainless steel, and it can be pushing or sliding. The 950 BM is able to do a self-learning procedure of the open and close positions and automatically measures the door weight for optimal operation. An optional "closing stroke" function ensures that the door stays closed even under strong wind. It also has an optional "push and go" function and in case of power failure the door can be opened manually then closed with the help of the spring

## 1. DESCRIPTION AND TECHNICAL CHARACTERISTICS

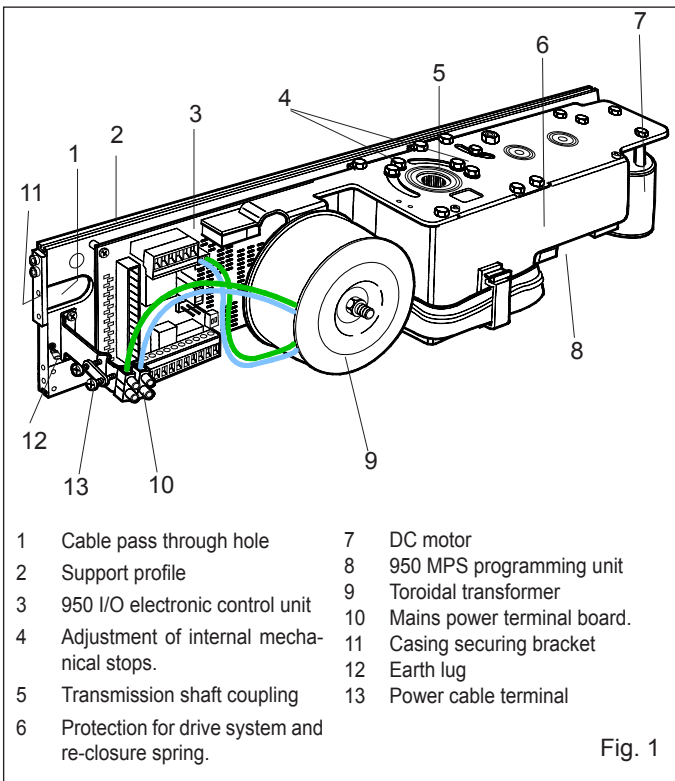


Table 1: Technical specifications of 950 BM Operator

<b>Power supply</b>	115 Vac (+6 -10%) - 60 Hz
<b>Absorbed power</b>	100 W
<b>Absorbed current</b>	1 A
<b>Electric motor</b>	24 Vdc with encoder
<b>Dimensions</b>	20 3/4 x 4 1/8 x 4 3/4 " (length x height x depth)
<b>Weight</b>	22 lbs
<b>Operating ambient temperature</b>	-4 to 131 °F
<b>Protection class</b>	IP 23 (internal use only)
<b>Dimensions and leaf max weight</b>	see Table 3 (paragraph 1.1)
<b>Use frequency</b>	continuous
<b>Operation in event of power failure</b>	Manual push/pull opening
<b>Configuration of driving arms</b>	<ul style="list-style-type: none"> <li>• pushing articulated arm (version for jamb depth 0 - 9 3/4" )</li> <li>• sliding arm (arm length 17")</li> </ul>
<b>Anti-crushing device</b>	standard
<b>Opening angle</b>	see table 5-6
<b>Opening speed</b>	4 to 10 s (adjustable)
<b>Closing speed</b>	4 to 10 s (adjustable)

Table 2: Technical specifications of Control Board 950 I/O and Control Board 950 MPS

<b>Power supply</b>	115 Vac (+6 -10%) - 60 Hz
<b>Accessories power supply</b>	24 Vdc / 500mA max
<b>Electric lock power supply (N.O./N.C.)</b>	24 Vdc / 500mA max
<b>Standard operating functions (selector switch)</b>	Open / Automatic Manual (Night)
<b>Adjustable functions (trimmer)</b>	Opening speed - Closing speed Pause time
<b>Selectable functions (microswitches)</b>	Closing stroke Standard/slide initialisation procedure Push and Go - Function selector switch (pos."2") STOP safety device operation - RS232 port
<b>Terminal block outputs</b>	Malfunction alarm signal Electric lock power supply (N.O./N.C) 24 Vdc accessories power supply - Door status signal Changeover relay controlled by Card Reader "Two-leaf door" signal - "Interlock" Signal
<b>Terminal block inputs</b>	Internal / External Commands Emergency Command - Key Command Card Reader Command - Fire-alarm Command STOP Safety device - Closing Safety device
<b>Rapid connectors</b>	KP-CONTROLLER (optional) Minidec Decoder or RP cards connection Functions selector switch connection

### 1.1. APPLICATION LIMITS

**Important:** To ensure correct application of the FAAC 950 BM unit the weight of the door must not exceed the value given in Table 3 referred to its length. The maximum length of the leaf is 55".

The values of maximum weight vary according to the driving arm used.

For each driving arm there is also a different maximum value for the depth of the jamb (Table 4) beyond which it is not possible to install the system correctly.

Table 3: Application limits of 950 BM operator

Leaf length (inches)	Max leaf weight (lbs) Articulated arm	Max leaf weight (lbs) Sliding arm
27 1/2	809	-
29 1/2	705	-
31 1/2	619	-
33 1/2	548	428
35 1/2	489	381
37 1/2	438	342
39 1/2	396	309
41	359	280
43	328	256
45	299	234
47	275	214
49	254	198
51	236	183
53	218	170
55	203	157

Table 4: Max jamb depth

	Pushing articulated arm	Sliding arm
	0 - 9 3/4	0 - 6 1/4

1.2 DOOR MAX OPENING ANGLE

According to the type of mounting and following the installation dimensions shown in Tables A or B, different door max. opening angles can be obtained according to the lintel thickness. Table 5 and 6 shows the maximum values of the opening angles that can be obtained in the different configurations.

Tab.5: Door max opening angle with pushing articulated arm

Type of installation	Jamb depth (mm)	Max opening angle
operator on lintel	0	100°
operator on lintel	125	110°
operator on lintel	250	125°

Tab.6: Door max opening angle with sliding arm

Jamb depth (mm)	Max opening angle
0	90°
160	105°

2. ELECTRICAL SETUP (fig. 2a Standard system)

- 1 950 BM operator
- 2 Microwave radar / Passive infrared sensor
- 3 T20E outdoor key-operated selector switch (KEY command)
- 4 Emergency Closing/Opening pushbutton
- 5 KP-CONTROLLER programming unit (optional)
- 6 KP-CONTROLLER inhibition switch (optional)
- 7 24 Vdc electric lock
- 8 Junction box

Notes: 1) To lay electric cables, use suitable rigid and/or flexible piping.  
 2) Always keep the low voltage accessory connection cables separate from the 115 V power cables. To avoid interference, use separate sheaths.

3. INSTALLATION

3.1. PRELIMINARY CHECKS

To ensure correct operation of the automated system the structure of the existing door must meet the following requirements:

- length and weight as specified in Table 3 (paragraph 1.1.);
- max. jamb depth as specified in Table 4;
- robust and rigid structure of the leaf;
- good condition of the existing hinges;
- smooth, uniform movement of the leaf with no abnormal friction during its entire travel;
- "neutral" position of the door during its entire travel. If the door tends to close or open, check the alignment of the hinges.
- Presence of mechanical travel stops.

3.2. MOUNTING THE OPERATOR

- 1) For details on the mounting position of the operator and the type of arm to use (pushing or sliding), refer to the relevant mounting table and drill the holes required to mount the operator and the arm.

NOTE: The two intermediate operator fixing holes are not in a central position (see Mounting tables). The holes are offset in order to ensure that the operator is mounted with the correct direction of rotation of the mechanism.

The mounting tables are the following:

Table A: LINTEL MOUNTING (PUSHING ARTICULATED ARM):  
 Outward opening.

Table B: LINTEL MOUNTING (SLIDING ARM):  
 Inward opening.

- 2) Mount the casing fixing brackets as shown in fig.3 according to the type of mounting to be made. Tighten the screws (fig.3-ref.1) and fit the screws (fig.3-ref2) without tightening them completely.
- 3) Mount the operator using the six M6 screws and washers provided.

Warning:

- The structure of the lintel (or the door) at the operator mounting position must not exhibit any significant deformation.
- The operator must be mounted parallel to the floor.

NOTE: If the sliding arm is to be used, the driving arm must be mounted before the operator is fixed on the lintel (see paragraph 3.3.2.).

3.3. MOUNTING THE DRIVING ARMS

3.3.1. MOUNTING THE PUSHING ARTICULATED ARM (fig.5)

- 1) Close the door.
- 2) Free arms (1) and (2) by loosening the fixing dowel (3) as shown in fig.5.
- 3) Fit arm (1) on the coupling of the operator transmission shaft by means of the standard shaft (8) and the screw (4) provided (fig.5). The arm must be mounted perpendicular to the closed door.

Note: If a greater distance between the operator and the arm is required, use the shaft modular extensions, available as accessories, until the required distance is reached. (see Table A/B).

- 4) Mount plate (5) of arm (2) on the door or the lintel using the two M6 screws and the washers provided (fig. 5). The installation dimensions are given in Table A/B.
- 5) Slacken the fixing screw (6) and assemble the two arms by tightening the dowel (3) (fig.5).
- 6) Turn arm (1) until arm (2) is perpendicular to the closed door or the lintel as shown in fig. 5 (a-b), sliding the spacer (7) along arm (2).
- 7) Tighten the fixing screw (6) between the two arms. The length of arm (2) is given in the relevant mounting tables. If necessary, cut off the section of the arm extending beyond the articulation and then cover its end using the cap provided (fig. 5).
- 8) Check manually that the door is free to open and close fully and that it comes to rest against the mechanical stops. If the door does not close correctly, adjust the return spring as described in paragraph 9.

Important: The two driving arms must never touch.

NOTE: it is advisable to always adjust the operator internal mechanical stops (fig.1 -ref 4), open/closed, so that they are reached at the same time when the leaf mechanical stops are reached.

3.3.2. MOUNTING THE SLIDING ARM (fig.6)

- 1) Mount arm (1) on the operator transmission shaft by means of the standard shaft (5) and the screw (2) provided (fig.6). The arm must be fitted pointing 45° outwards as shown in fig. 6(a).

Note: If a larger distance is required between the operator and the arm use the shaft modular extensions available as accessories, until the required distance is reached (see Table C/D).

Warning: Mount arm (1) on the transmission shaft before fitting the operator on the lintel (fig.6).

- 2) Insert the teflon slide (3) inside the sliding guide (4) (fig.6).
- 3) Pull arm (1) inwards manually as shown in fig. 6(b) and secure the sliding guide (4) by means of two M6 screws on the closed door as shown in Table C/D.
- 4) Check manually that the door is free to open and close fully and comes to rest against the mechanical travel stops. If the door does not close correctly, adjust the return spring as described in paragraph 9.

**4. START-UP**

1) Make the electrical connections to the 950 I/O electronic control unit as described in paragraph 6, and connect the mains power supply to the specific terminal (fig.1-ref.10) ensuring to crimp the earth wire to the lug (fig.1-ref.12) screwed to the support profile (fig.1-ref.2). Then tighten the terminal (fig.1-ref.13)

To gain access to the control unit, pass the cables through the special conduit (fig.1-ref.1) or break the knockout areas on the casing sides (fig.4-ref.6).

**IMPORTANT:** When mounting the sliding arm or for opening angles greater than 90°, turn microswitch no. 2 to ON before connecting power to the system.

- 2) Close the door.
- 3) Power up the operator.
- 4) Check that the green LEDs LD1 and LD3 on the board 950MPS light up.
- 5) Check that the status signalling LEDs on the board 950I/O are in the default status shown in Table 7 .

**NOTE:** The default status of the LEDs with the door closed at rest is shown in bold type.

**Table 7: Operation of the status signalling LEDs for 950 I/O board**

LED	ON	OFF
LD1	<b>Accessories power present</b>	Accessories power absent
LD2	Card Reader active	<b>Card Reader inactive</b>
LD3	Internal sensor active	<b>Internal sensor inactive</b>
LD4	External sensor active	<b>External sensor inactive</b>
LD5	<b>Emergency inactive</b>	Emergency active
LD6	<b>STOP safety device inactive</b>	STOP safety device active
LD7	<b>CL safety device inactive</b>	CL safety device active
LD8	Key active	<b>Key inactive</b>
LD9	Fire-alarm active	<b>Fire-alarm active</b>

6) Run a SET-UP cycle as indicated in paragraph 4.1.

**4.1. SET UP PROCESS**

Once the system is powered up, hold down SW1 button for at least 5 sec., until the LD2 red LED on the 950MPS board lights up. The LED will start flashing to indicate that SET UP process is in progress. During this process the following parameters are set:

- measuring the mass of the door;
  - determining the travel stop positions;
- The door opens at low speed, then closes half way before switching back to opening.

Subsequent closure is performed by the return spring. The process may be inhibited in any of the following conditions:

- function selector switch in the 2 (MANUAL/NIGHT) position or KP-CONTROLLER programming unit in MANUAL or NIGHT position.
- incorrect connection of the accessories (electric lock, control/safety devices);
- incorrect positioning of the programming unit microswitches.

**NOTE:** To repeat the initialisation procedure hold down the SW1 button for more than 5 seconds.

Check that door opens and closes correctly by sending an opening command to one of the following inputs: Internal Sensor, External Sensor or Key command. Set the trimmers (par.5.2) and program the microswitches (par.5.4) according requirements.

**5. 950 MPS ELECTRONIC CONTROL UNIT (Fig. 8)**

**5.1 SETTING THE TRIMMERS**

The programming unit features trimmers (fig.8) which regulate the following parameters:

**Trimmer TR1** to set the opening speed.  
Setting from 4 to 10 seconds.

**Trimmer TR2** to set the closing speed.  
Setting from 4 to 10 seconds.

**Trimmer TR3** to set the pause time (AUTOMATIC logic).  
Setting from 0 to 30 seconds.

**5.2 SIGNALLING LEDs**

**LD1 Led** = Green LED - electric motor power supply.

**LD2 Led** = Red LED - indicates SET-UP/Alarm.

**LD3 Led** = Green LED - 5V power supply.

**950MPS ELECTRONIC CONTROL UNIT LAYOUT AND DESCRIPTION**

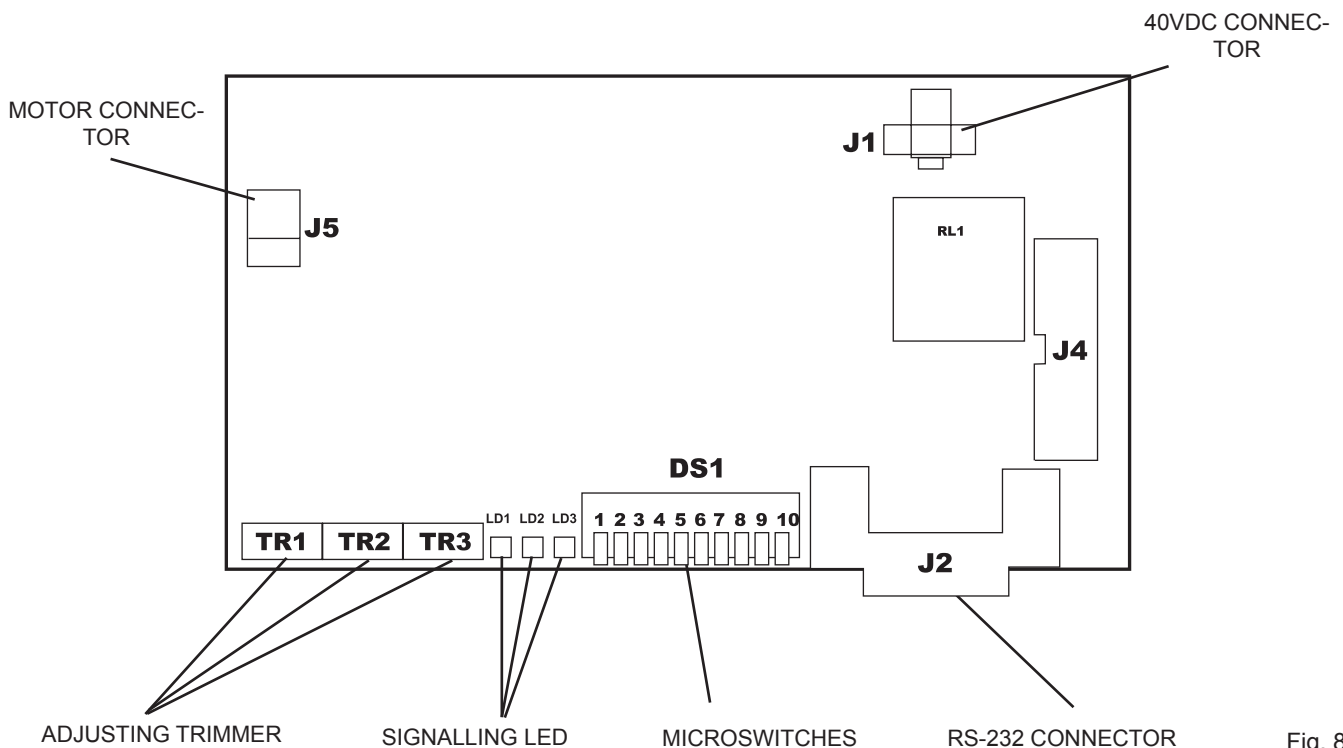


Fig. 8

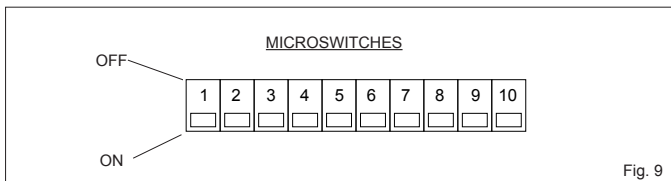


5.4. PROGRAMMING THE MICROSWITCHES (fig.9)

The 950BM has two series of microswitches, one on the 950MPS board and one on the 950 I/O board.  
The system is supplied with all the microswitches in the OFF position.

Tab. 8: DS1 on the 950MPS board

N°	Function	OFF	ON
1	Closing stroke	Disabled	Enabled
2	Setup process	Standard	Non-standard
3	Outside selector - pos. 2	Manual	Night
4	Push And Go	Disabled	Enabled
5	Not in use	-	-
6	Not in use	-	-
7	Safety STOP detection	Complete	Reduced
8	SCP	Disabled	Enabled
9	Not in use	-	-
10	RS232 Port	Disabled	Enabled



5.4.1. MICROSWITCH No. 1 - CLOSING STROKE

This function enables the closed position force to be increased by further loading the transmission system after the door has reached the mechanical closure stop.

It is advisable to use this function to assist activation of the electric lock.

- OFF = Function DISABLED
- ON = Function ENABLED

5.4.2. MICROSWITCH No. 2 - SET-UP PROCESS

When mounting the "sliding" arm or for opening angles greater than 90°, this microswitch has to be enabled.

- OFF = Function DISABLED
- ON = Function ENABLED

5.4.3. MICROSWITCH No. 3 - SELECTOR FUNCTION

This function allows the operating function to be selected with the selector switch in the "2" position.

- OFF = MANUAL Function
- ON = NIGHT Function

5.4.4. MICROSWITCH No. 4 - PUSH AND GO

When activated, this function enables the opening command to be given by pushing the closed door manually. It is sufficient to give the door an initial push/pull in the opening direction.

- OFF = Function DISABLED
- ON = Function ENABLED

WARNING: It is advisable not to enable this function if the door is subject to strong wind, according to its structure and dimensions, as this could activate the system's spontaneous opening or motion reversing.

5.4.5. MICROSWITCHES Nos. 5/6/9 - INACTIVE

5.4.6. MICROSWITCH No. 7 - STOP SAFETY DEVICE

It makes it possible to detect activation of the STOP safety device during the entire door travel (COMPLETE) or to disable detection beyond 70° opening (REDUCED).

- OFF = COMPLETE Function
- ON = REDUCED Function

When the STOP safety control is ensured by an active sensor fitted on the leaf, if you enable the REDUCED function, the detection of any obstacle (e.g. side wall) is prevented which would cause interruption of the work cycle.

5.4.6. MICROSWITCH No. 8 - SCP Function

SCP Function (Selectable Close Power)

If the SCP function is enabled, the door can be closed even if there is friction due to rigid seals or electric locks with a particularly difficult connection. When the SCP function is operating, the electronic anti-crush facility is still active, but is less sensitive. For reasons of safety, we therefore advise you to use the function only in case of real need.

- OFF = Function DISABLED
- ON = Function ENABLED

6. 950 I/O ELECTRONIC CONTROL UNIT LAYOUT

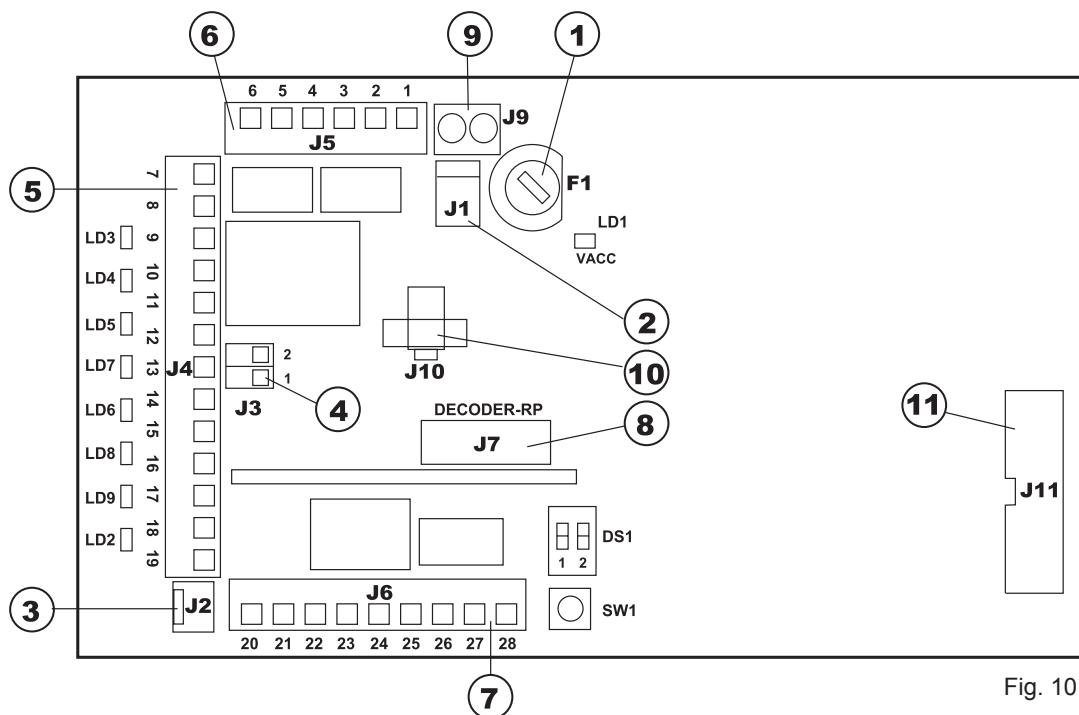


Fig. 10

**5.4.7 MICROSWITCH No. 10 - RS232 PORT**

It makes it possible to enable the RS232 port connection to PC for software update. In normal use conditions, the dip switch is in OFF position.

- OFF = Port DISABLED
- ON = Port ENABLED

**6. 950 I/O ELECTRONIC CONTROL UNIT (Fig. 10)**

**6.1 LAYOUT AND DESCRIPTION**

**DS1**

N°	Function	OFF	ON
1	Push and Go pause time	2 seconds	Automatic
2	Opening delay with electric lock	200ms	500ms

**MICROSWITCH No. 1 - Push and go Pause time**

Following the opening with the Push & Go function you can choose: to have the automated system use a fixed 2 seconds pause time, or the time used by opening with the pulse generator in automatic operating mode (see chap. 10.7 - Diagram 3: Setup).

- OFF = 2 sec. pause time
- ON = Automatic pause time

**MICROSWITCH No. 2 - Lock activation delay**

If this dip-switch is ON (enabled), the door movement is delayed by 500msec with respect to the electric lock command. If OFF (disabled), delay is 200 msec.

**SW1 SET-UP pushbutton**

Hold down the SET-UP button for 5 sec. to start the set-up cycle.

- ① **FUSE F1** T4A 125 Vac. - 5x20 (UL/CSA)
- ② **J1 CONNECTOR** Transformer Secondary winding - fig. 10
- ③ **J2 CONNECTOR** Rapid Connector of Manual/Night, Open, Automatic function selector switch
- ④ **J3 CONNECTOR** KP-Controller Connection

1- 2 Connector of KP-Controller programming unit (optional) as shown in fig. 24.

Use a 2 x 0.5 mm<sup>2</sup> shielded cable ("bus" communication) for the connection. Respect the connection polarity as shown in figure 24.

Important: The maximum permissible length of the connection cable is 150'.

To inhibit operation of the SD-KEEPER, make the jumper between terminals of the LOCK switch (fig.24).

**⑤ J4 TERMINAL BLOCK** Inputs Connection (figs. 11,12,16)

**7- 8 GND**

Accessories power supply Negative and contacts Common

**9 +24Vdc**

+24Vdc accessories power supply

**10 Internal Command - N.O. Contact**

Any pulse generator (pushbutton, sensor, etc.) which, by closing a contact, commands door opening.

To install several pulse generators as Internal Command, connect the N.O. contacts in parallel.

**11 External Command - N.O. Contact**

Any pulse generator (pushbutton, sensor, etc.) which, by closing a contact, commands door opening.

To install several pulse generators as External Command, connect the N.O. contacts in parallel.

**12 Emergency Command - N.C. Contact**

Any pulse generator (normally a pushbutton) which, by opening a contact, commands an emergency closure of the system. Alternatively this input can be used to command emergency opening by programming the system in a suitable manner using the KP-CONTROLLER programming unit (optional).

To install several emergency command devices, connect the N.C. contacts in series.

NOTE: If emergency command devices are not connected, jumper inputs 7 and 12.

Attention: Using the KP-CONTROLLER programming unit, you can change the type of contact from N.C. to N.O.

**13 CLOSE Safety Command - N.C. Contact**

Any device (safety sensor, photocell, etc.) which, by opening a contact, has a safety effect on the closing movement of the door. The safety device causes an immediate reversing of the closing movement of the door, but has no effect on the opening movement of the door.

To install several CLOSE safety devices, connect the N.C. contacts in series.

N.B.: If the CLOSE safety devices are not installed, jumper inputs 7 and 14.

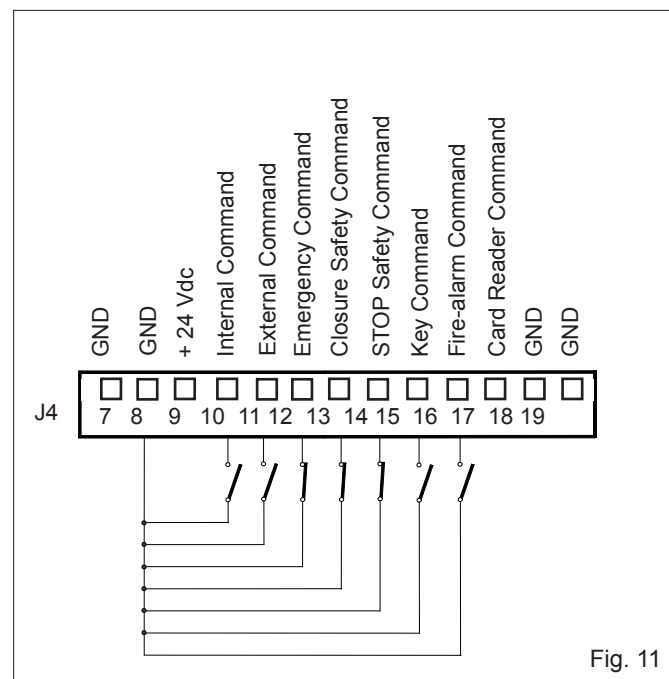


Fig. 11

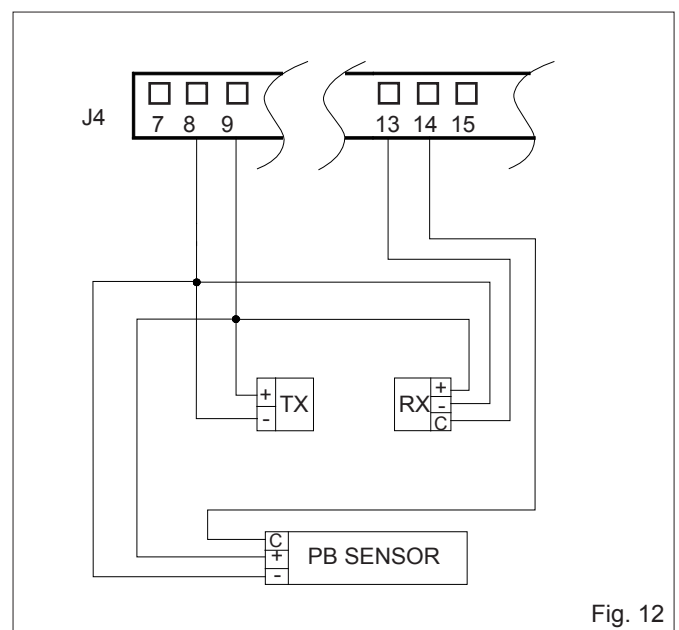


Fig. 12

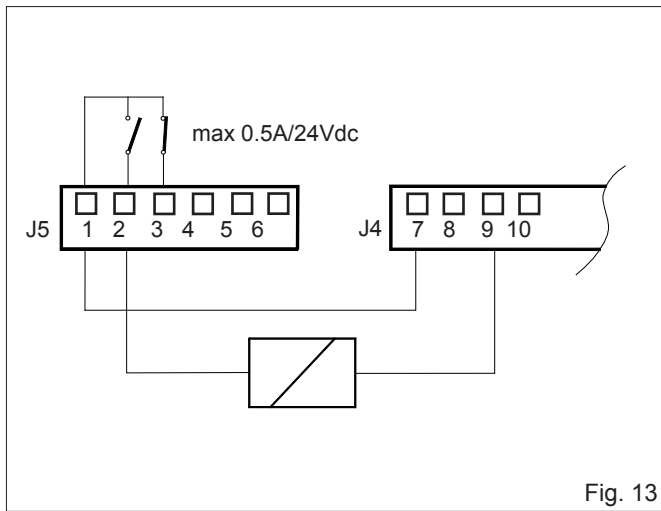


Fig. 13

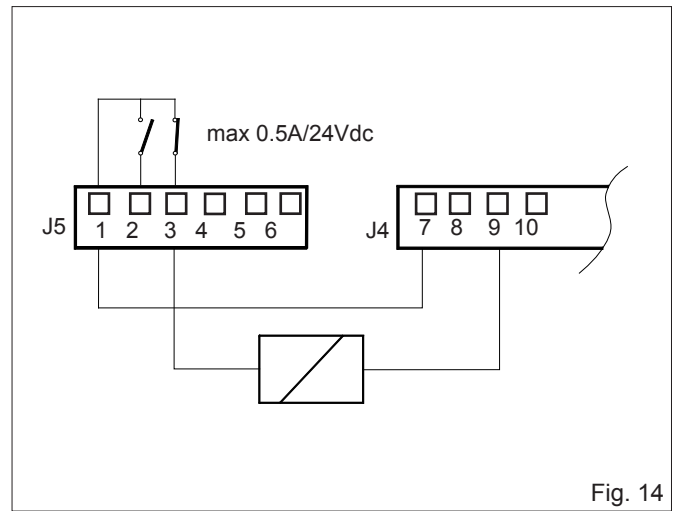


Fig. 14

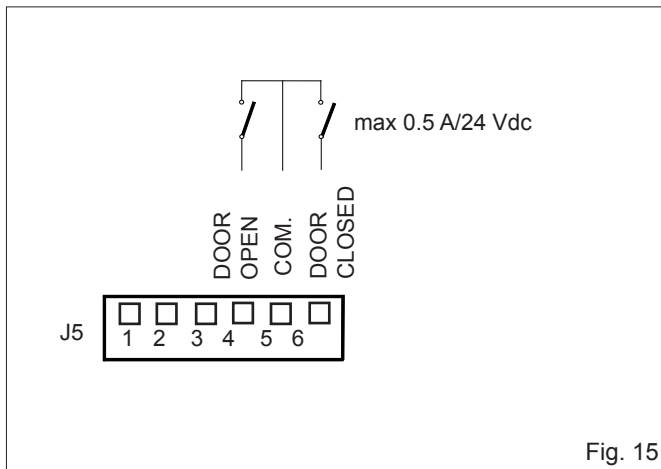


Fig. 15

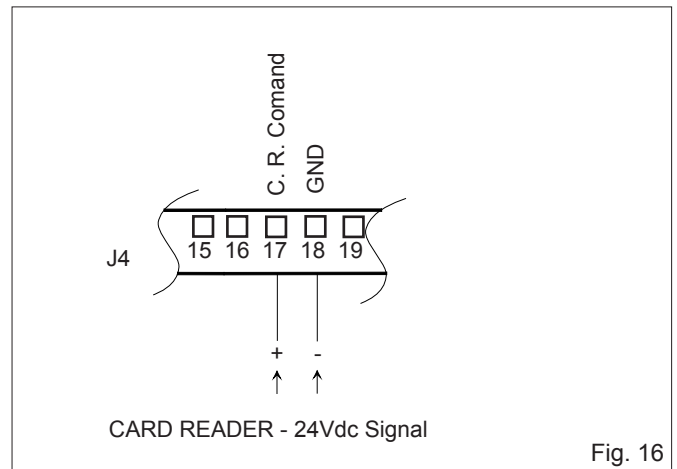


Fig. 16

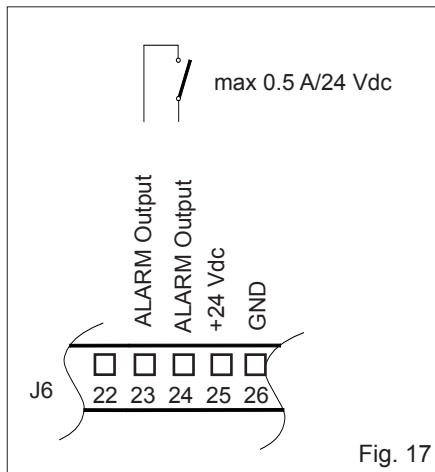


Fig. 17

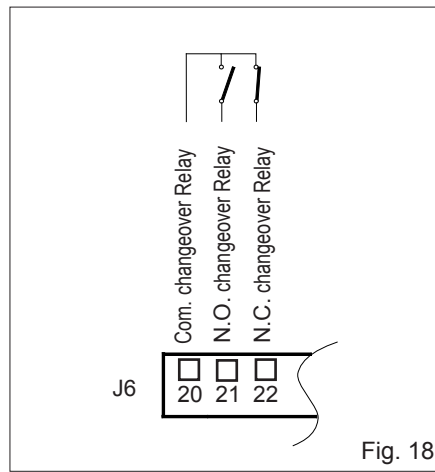


Fig. 18

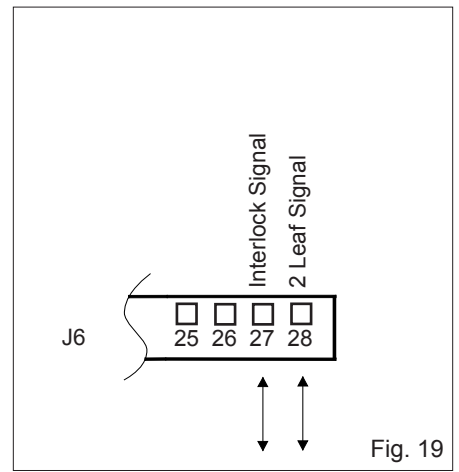


Fig. 19

**14 STOP Safety Command - N.C. Contact**

Any device (safety sensor, photocell, etc.) which, by opening a contact, has a safety effect on the operating cycle. In particular, this safety device interrupts the opening/closing movement of the door.

When the safety device is disengaged, the door resumes its opening/closing movement and continues to the end of the cycle. To install several STOP safety devices, connect the N.C. contacts in series.

N.B.: If STOP safety devices are not installed, jumper inputs 7 and 13.

**15 KEY Command - N.O. Contact**

Any pulse generator (pushbutton, sensor, etc.) which, by closing a contact, commands door opening.

To install several pulse generators as Internal Command, connect the N.O. contacts in parallel.

**16 FIRE-ALARM Command - N.O. Contact**

Any device (fire-alarm sensor, etc.) which, by closing a contact, commands door closing.

Permanence of the closed contact, inhibits operation of any other pulse generator.

To install several devices as FIRE-ALARM Command, connect the N.O. contacts in parallel.

**17 CARD READER Command - N.O. Contact**

Any device (card reader, digital buttonboards, etc.) which, by giving a 24Vdc pulse, commands the door opening and the activation of the changeover relay (terminals 20/21/22, J6 terminal board). The open pause time is fixed at 10 sec.

**18 - 19 GND**

Accessories power supply Negative and contacts Common

**⑥ J5 TERMINAL BLOCK** Connection to relay Outputs (figs. 13,14, 15)

- 1 Electric lock - Common**
- 2 Electric lock - N.O. Contact (max. capacity 0.5 A/24 V)** (fig.13).  
If no power is supplied the electric lock is active and therefore guarantees closing mechanical locking.  
In the NIGHT function the electric lock is active even if no power is supplied. In the event of an opening command (Key or EMERGENCY command), the electric lock is temporarily powered to enable the door to be opened. In this case a reverse stroke command is also given to enable the mechanical release of the system.
- 3 Electric lock - N.C. contact (max. capacity 0.5 A/24 V)** (fig.14).  
The output is suitable for commanding a magnetic closure system. If no power is supplied, the electric lock is not active. In the NIGHT function the electric lock is powered and hence active. In the event of an opening command (internal command or EMERGENCY OPENING), the power supply to the electric lock is temporarily cut off to allow the door to be opened.
- 4 Door status CLOSED - N.O. contact (max. capacity 0.5 A/24 V).**  
When the door CLOSED position is reached, the contact closes.
- 5 Door status - Common**
- 6 Door status OPEN - N.O. contact (max. capacity 0.5 A/24 V).**  
When the door OPEN position is reached, the contact closes.

**⑦ J6 TERMINAL BLOCK** Relay outputs and special functions (figs. 17, 18, 19)

- 20 Changeover relay - Common**
- 21 Changeover relay - N.O. Contact**  
This output is activated (N.C.) by the Card Reader input for 2 sec. Attention: this output is not suitable for controlling electric locks.
- 22 Changeover relay - N.C. Contact**  
This output is activated (N.O.) by the Card Reader input for 2 sec. Attention: this output is not suitable for controlling electric locks.
- 23 Alarm Output - Common**
- 24 Alarm Output - N.O. Contact**  
This output is activated (N.C.) if an alarm is present. At the same time LED2 on the 950 I/O board lights up to indicate the alarm condition.
- 25 +24Vdc**  
+24Vdc accessories power supply

- 26 GND**  
Accessories power supply Negative and contacts Common
- 27 "Interlock" output**  
This terminal is used to enable communication between two 950BM automated systems programmed in "Interlock" configuration, see par. 11.1.
- 28 "2 Leaves" output**  
This terminal is used to enable communication between two 950BM automated systems programmed in "2 Leaves" configuration, see par. 11.2.

**⑧ J7 Connector** Quick-fit connector for connecting RP plug-in Receivers or Minidec/Decoder decoding cards (fig. 10).

**⑨ J9 TERMINAL BLOCK NOT-AUS** (fig. 10)  
N.C. contact for emergency stop. If there is no connection between the two terminals, the automated system is locked and cannot perform any electrical movement.

**⑩ J10 Connector** Quick-fit connector for 40Vdc power supply to 950 MPS board (fig.10)

**⑪ J11 Connector** Quick-fit connector for door status signals to 950 MPS (fig.10)

**7. INSTALLING THE COVER**

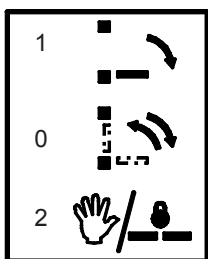
Please refer to Fig. 4 for the cover assembly instructions. The parts are:

- 1 Side cover support (2 included)
- 2 Side cover support screws (4 included - 2 per side)
- 3 Side cover (2 included)
- 4 Side selector cover screws (4 included - 2 per side)
- 5 Selector cover (2 included)
- 6 Selector switch
- 7 Aluminum cover
- 8 Cover screws (2 included)

For best results assemble the parts following the above order 1 thru 8.

**8. FUNCTION SELECTOR SWITCH**

The 950 BM operator has a 3-position function selector switch (0-1-2) mounted on one side of the cover (fig. 4 - ref. 2). The selector switch position is fixed: however, depending on the type of installation (on doorpost or on lintel), the connection cable to the 950I/O unit must be positioned as shown in figs. 4a/b. The selector switch can be easily inspected by opening the protection door (fig. 4 - ref.1). The selectable operating functions are shown in fig. 20.



**POSITION "1": OPEN**

When this function is selected, the door opens and remains open.

**POSITION "0": AUTOMATIC**

If this function is selected, when an internal/external command is given, the door opens and then re-closes after the pause time.

**POSITION "2": MANUAL/NIGHT**

The position "2" can be used to select two different operating functions according to the programming carried out on the 950 MPS programming unit (see paragraph 5.4.3). The two functions are:

**MANUAL:** The door can be opened manually.

**NIGHT:** The external command is inactive. The door can be opened solely by activating the Key command (fig. 11) .

Fig. 20

**9. ADJUSTING THE SPRING**

**9.1. SPRING PRELOADING**

If the door movement is not uniform (e.g.: door not closing completely or closing with too much force) proceed as follows to adjust the spring preloading:

- 1) Cut power to the automated system and release from the door the arm secured directly on the transmission shaft;
- 2) Rotate the arm until the stop-point screw (fig. 21 ref.4) is in line with the inspection slot (fig. 21 ref. 3) ;
- 3) Remove the screw, while keeping the arm in position;
- 4) To increase preloading: rotate the arm in opening direction until the next fixing position of the stop-point screw (fig.21 ref.5) is in line with the inspection slot and fix the screw again.  
To reduce preloading: rotate the arm in closing direction until the next fixing position of the stop-point screw (fig.21 ref.5) is in line with the inspection slot and fix the screw again.
- 5) Reinstall the arm correctly (see par.3.3.);
- 6) Run a new SETUP cycle.

**9.2. CHECKING SPRING EFFICIENCY**

We advise you to periodically check the efficiency of the spring - this is the procedure:

- 1) Select the Manual function;
- 2) Remove the protective device of the drive system (see fig. 1 ref. 6);
- 1) With the door closed, trace a vertical line on the spring (fig. 22 ref.1 );
- 2) Open the door completely;
- 3) Check the line you had traced.  
If the distortion is not uniform along the whole spring height (fig. 22 ref.2 ), but is irregular (fig.22 ref.3 ), lubricate the spring with specific sliding grease.

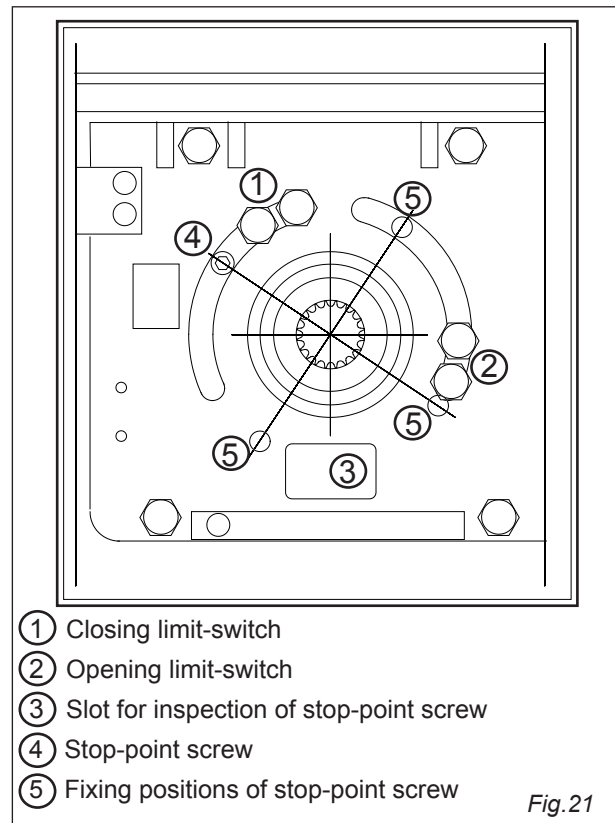


Fig.21

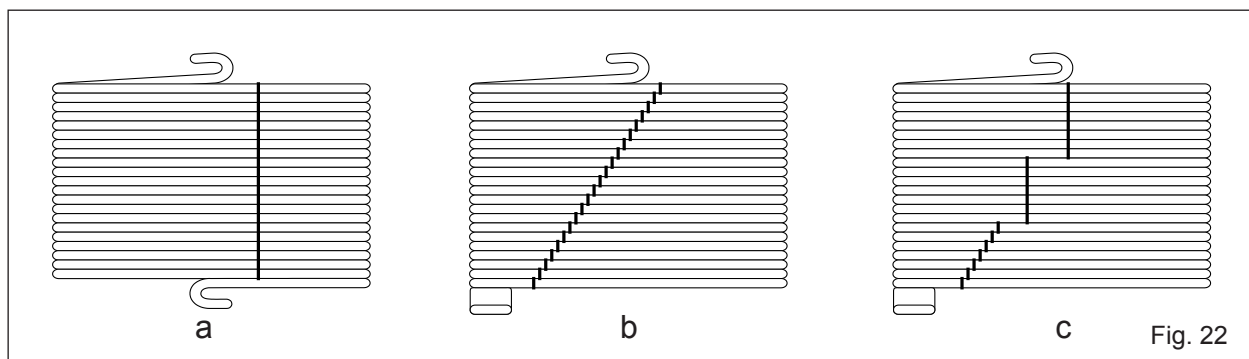


Fig. 22

**10. KP-CONTROLLER PROGRAMMING UNIT**

The KP-Controller is used for selecting operational functions, as well as adjusting and programming the 950 Series automatic doors. It is divided into two parts: a fixed part used for signalling of operational functions by means of pushbuttons and relevant signalling LEDs (Fig. 23 ref.A), and a removable part with LCD display and selection buttons to access complete programming (Fig. 23 ref.B).

The KP-Controller display can be used as a temporary programming unit if the parameter "Keep settings" in the ADVANCED MENU is set to ON: after all programming and adjustments have been carried out, KP-Controller can be fully removed because the settings remain stored on the 950MPS control board.

If KP-Controller is installed without display, a cover is provided (Fig. 23 ref.C).

KP-Controller can be disabled by a combination of keys (see the special LOCK function) or by internally installing a jumper that acts as a switch (Fig. 24 ref. LOCK).

**10.1. MOUNTING**

Refer to Fig. 24 for an exploded view of mounting; two knockout areas marked A and B are provided for entry of connection cable.

**10.2 . CONNECTIONS**

Connect the KP-Controller to the 950 I/O control board by a 2x0.5mm<sup>2</sup> max 50m cable (Fig. 24).

If the two LOCK terminals are connected to each other as shown in Fig.24, all keys on the programmer are disabled.

**10.3 . DIAGNOSTICS**

The KP-Controller (also without display) has a diagnostic function which, in case of an alarm, interrupts the normal display of the function every 2 seconds in order to show the fault status for 1 second by a combination of flashing LEDs.

Consult Fig. 25 and table 9 to identify the type of alarm according to the flashing LEDs. In the event of several simultaneous faults, the code of fault detected first is displayed.

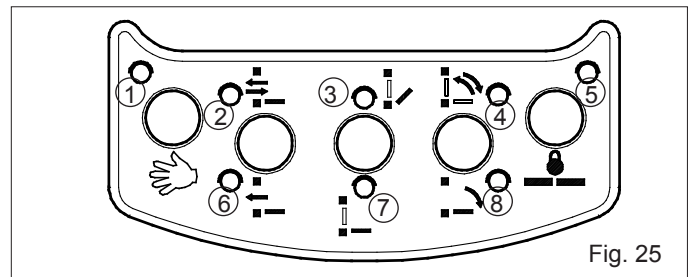
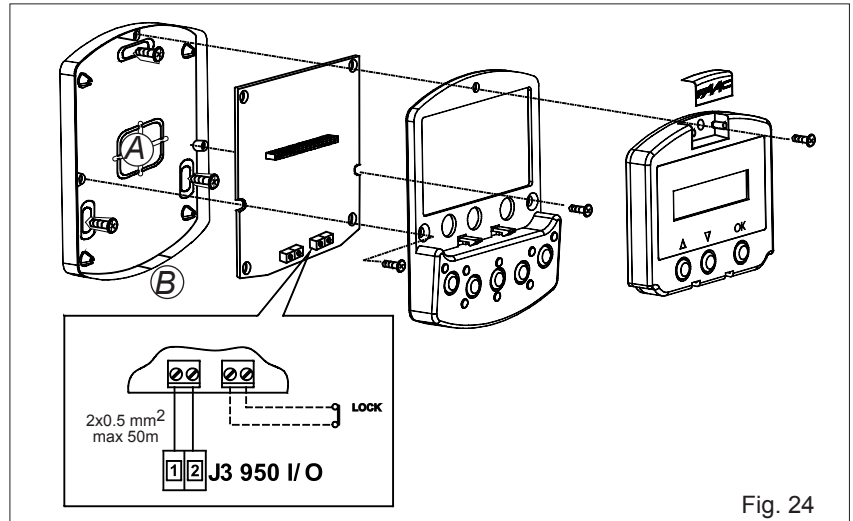
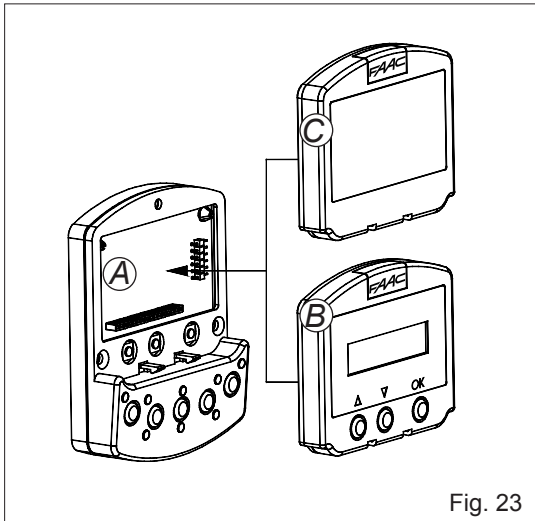


Fig. 23

Fig. 24

Fig. 25

**Table 9 DIAGNOSTICS**

DESCRIPTION	MEANING	Led							
		①	②	③	④	⑤	⑥	⑦	⑧
3 FORCED OPEN	Door forced opening in progress	○	○	●	○	○	○	○	○
7 EMERG. ON	Emergency input active	○	○	●	●	○	○	○	○
9 OBST. IN CLOS.	Closing obstacle detected 3 successive times; Reset necessary to restore operation	○	○	○	○	○	○	○	○
10 v	Lock locked in closed position	○	○	○	○	○	○	○	○
12 v	Incorrect power supply to accessories (24Vdc absent)	○	○	○	○	○	○	○	○
15 v	Setup not possible	○	○	○	○	○	○	○	○
18 v	Initialisation process not possible on motor: leaf stroke too long	○	○	○	○	○	○	○	○
20 v	Initialisation process not possible on motor: insufficient leaf stroke	○	○	○	○	○	○	○	○
22 v	Leaf too heavy	○	○	○	○	○	○	○	○
24 v	Motor failure	○	○	○	○	○	○	○	○
26 v	950 MPS control board failure	○	○	○	○	○	○	○	○
27 v	No power supply	○	○	○	○	○	○	○	○
28 v	Setup cycle required	○	○	○	○	○	○	○	○
29 v	Encoder failure	○	○	○	○	○	○	○	○
30 v	Driver motor failure	○	○	○	○	○	○	○	○
31 v	EEPROM failure	○	○	○	○	○	○	○	○
32 v	Master/Slave communication error	○	○	○	○	○	○	○	○

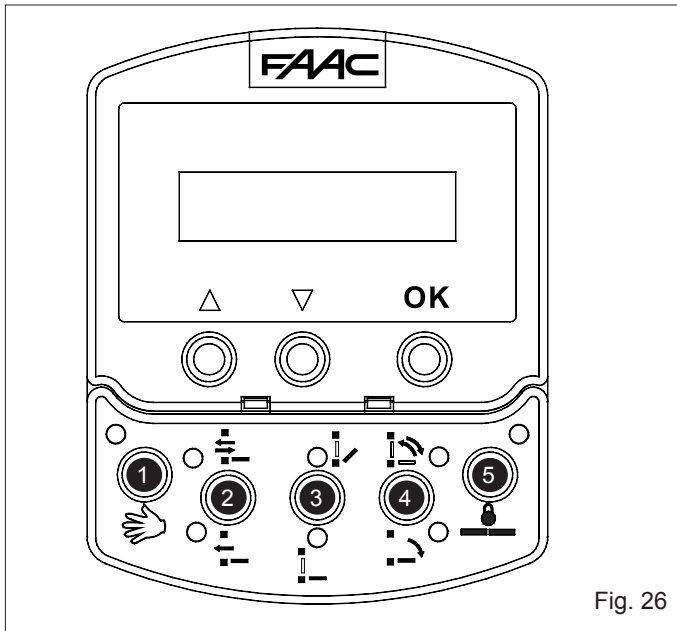


Fig. 26

1		MANUAL
2		BI-DIRECTIONAL ONE-WAY
3		PARTIAL OPENING TOTAL OPENING
4		AUTOMATIC DOOR OPEN
5		NIGHT

10.4 . OPERATIONAL FUNCTIONS

Selection is performed by pressing the keys on the fixed part of the programmer - the function is indicated by the corresponding LED lighting up.

**Note:** when the "Night" or "Manual" modes have been set, the relevant selection keys must be pressed to exit the modes.

**MANUAL**

The door is free and can be activated manually.

**BI-DIRECTIONAL**

Pedestrian transit is possible in both directions; the inside and outside radars are enabled.

**ONE-WAY**

Pedestrian transit is possible in one direction only; the external radar is disabled.

**PARTIAL OPENING**

The door opens only partially (standard: 80%)  
Partial opening can be adjusted in range from 60% to 90% of total.

**TOTAL OPENING**

The door opens completely.

**AUTOMATIC**

The door opens (partially or totally) and then re-closes after the set pause time (standard: 2 sec.).  
Pause time adjustment: form 0 to 30 sec.

**DOOR OPEN**

The door opens and stays open.

**NIGHT**

The door closes and the lock (if present) is activated. The internal and external radars are disabled.

The Key command causes opening and closing after the night pause time elapses (standard: 7 sec).

Adjusting range of night pause time: from 0 to 30 sec.

To obtain partial opening in this mode, before selecting the "Night" function, activate the "Partial Opening" function.

10.5 . SPECIAL FUNCTIONS

**SETUP**

Setup is the door initialisation function during which parameters are self-learned.

To activate, simultaneously press keys 1 and 5 for 5 sec.

**RESET**

Reset is the function for restoring normal operating conditions after some types of alarm have been signalled.

To activate, simultaneously press keys 2 and 3.

**LOCK**

When active, the Lock function disables the KP-Controller.

To activate and de-activate, simultaneously press keys 3 and 4 for 5 sec.

10.6 . INSERTING AND CHANGING BATTERY

To keep the clock inside KP-Controller active even in the event of a power failure, a 3V model CR1216 lithium battery has to be installed. To insert or replace the battery, find the compartment on the printed circuit (Fig. 27) and follow the indicated polarity.

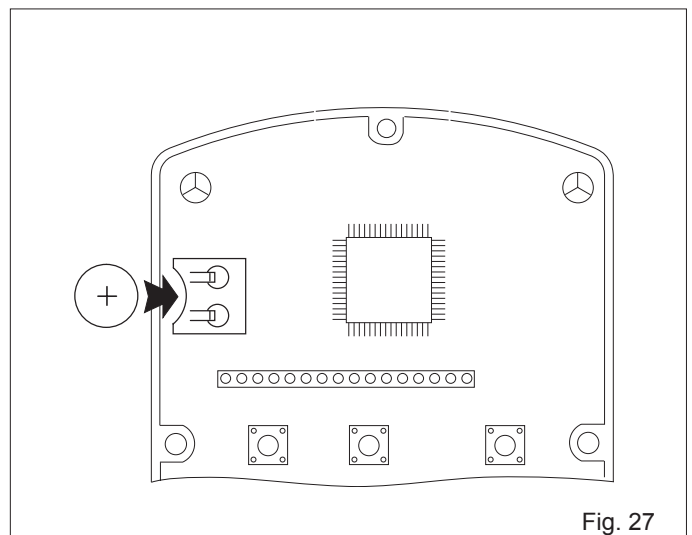
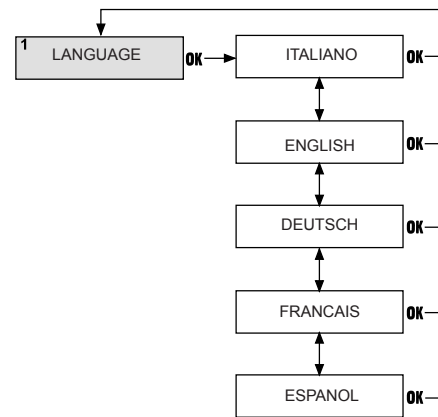


Fig. 27

**10.7. PROGRAMMING**

To access programming while the standard view is shown on the display, press any of keys ^, v or OK.  
 Programming is subdivided into main menus (see Chart 1) split into subjects.  
 After selecting the menu with keys ^ or v to access it press OK.  
 Each menu is, in turn, subdivided into sub-menus at different parameter setting levels.  
 Use keys ^ or v to select (sub-menu or parameter) and confirm with the OK key.  
 An asterisk on the display indicates the currently active setting.  
 To exit programming, select the "exit" function at each level. Otherwise, after about 2 minutes, the display automatically returns to standard view.  
 The following flow-charts and notes show the various programming menus and options.

**Diagram 2: Language selection**



**Diagram 1: Programming**

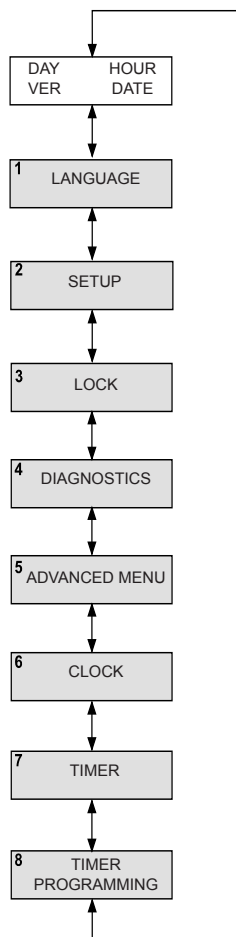




Diagram 3: Setup

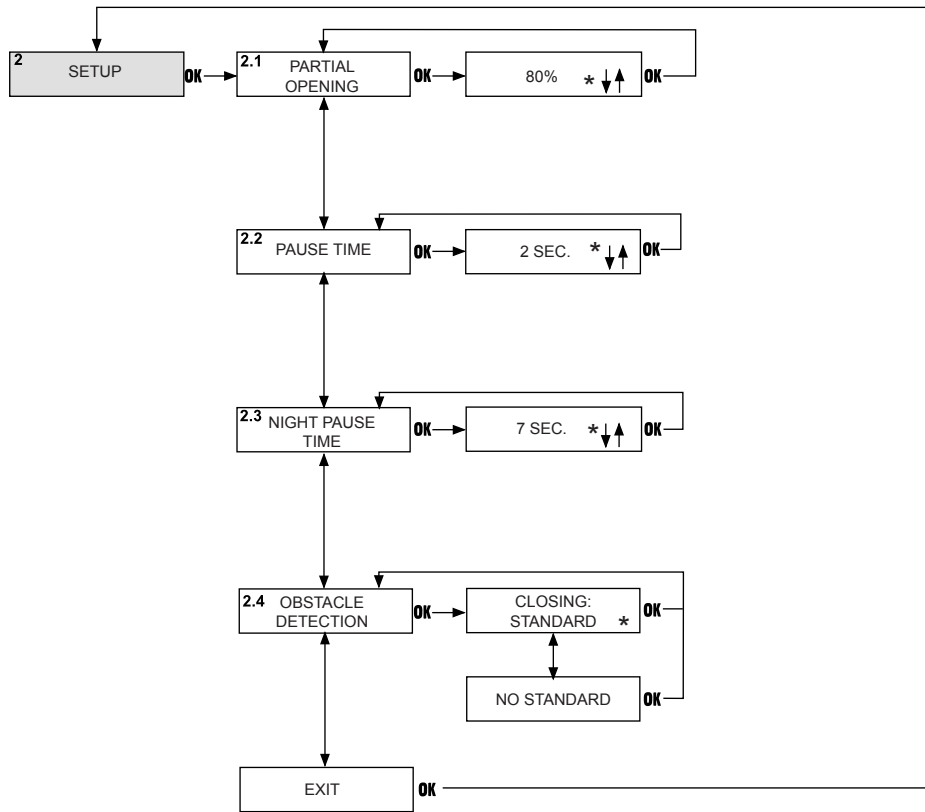


Diagram 4: Lock

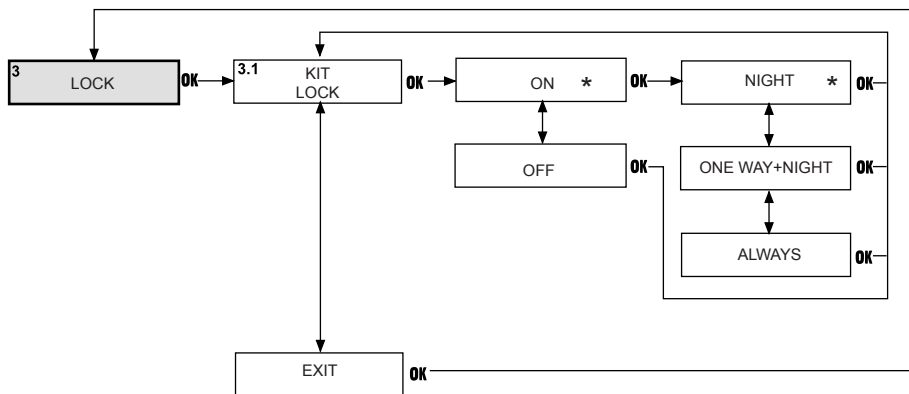


Diagram 5: Diagnostics

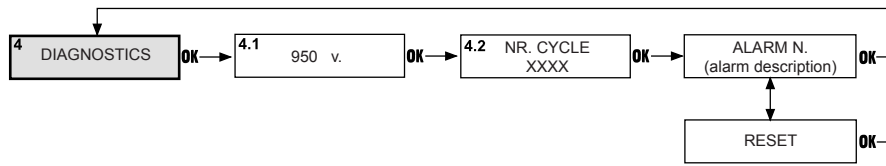


Diagram 6: Operation parameters

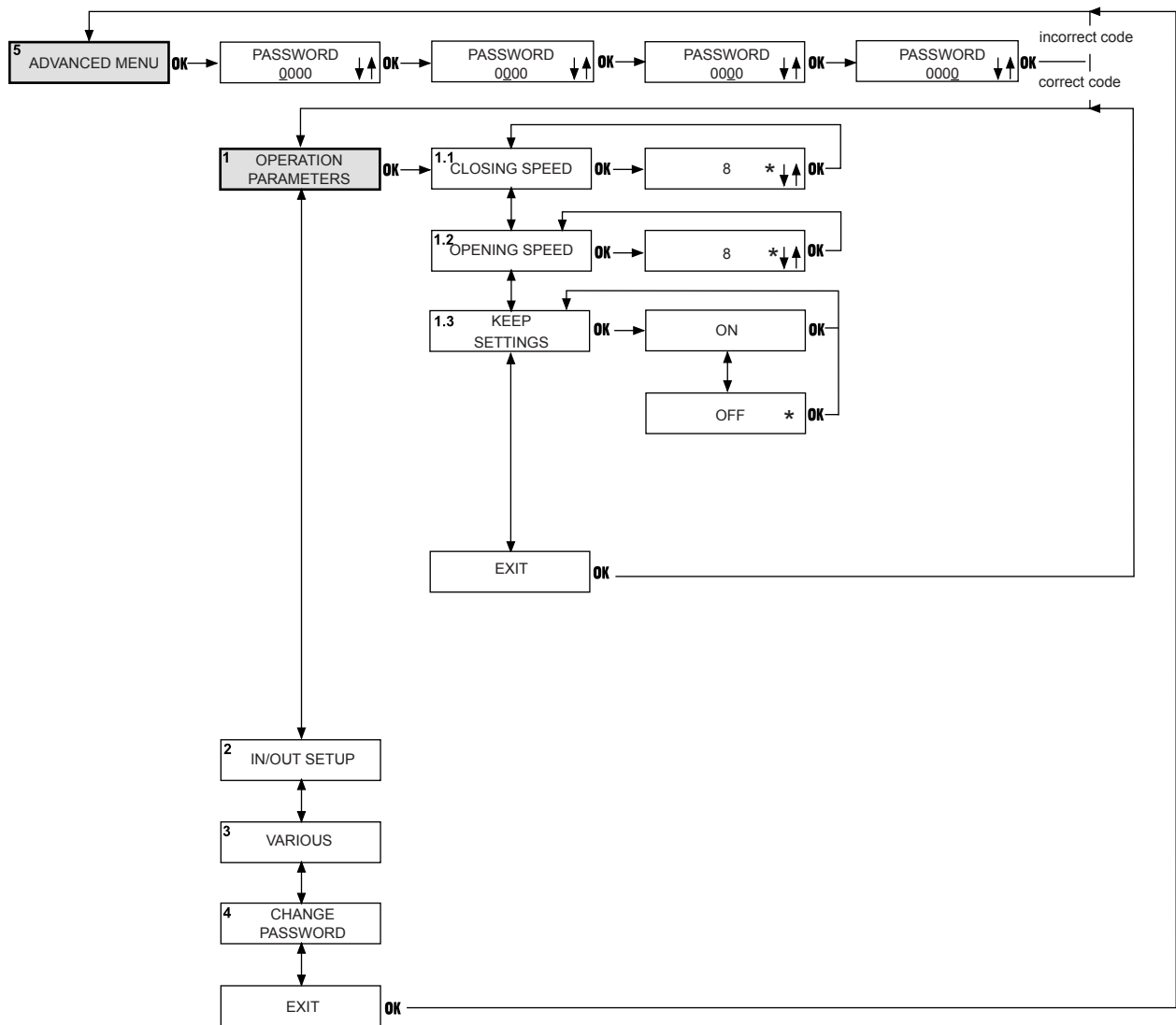


Diagram 7: In/Out Setup

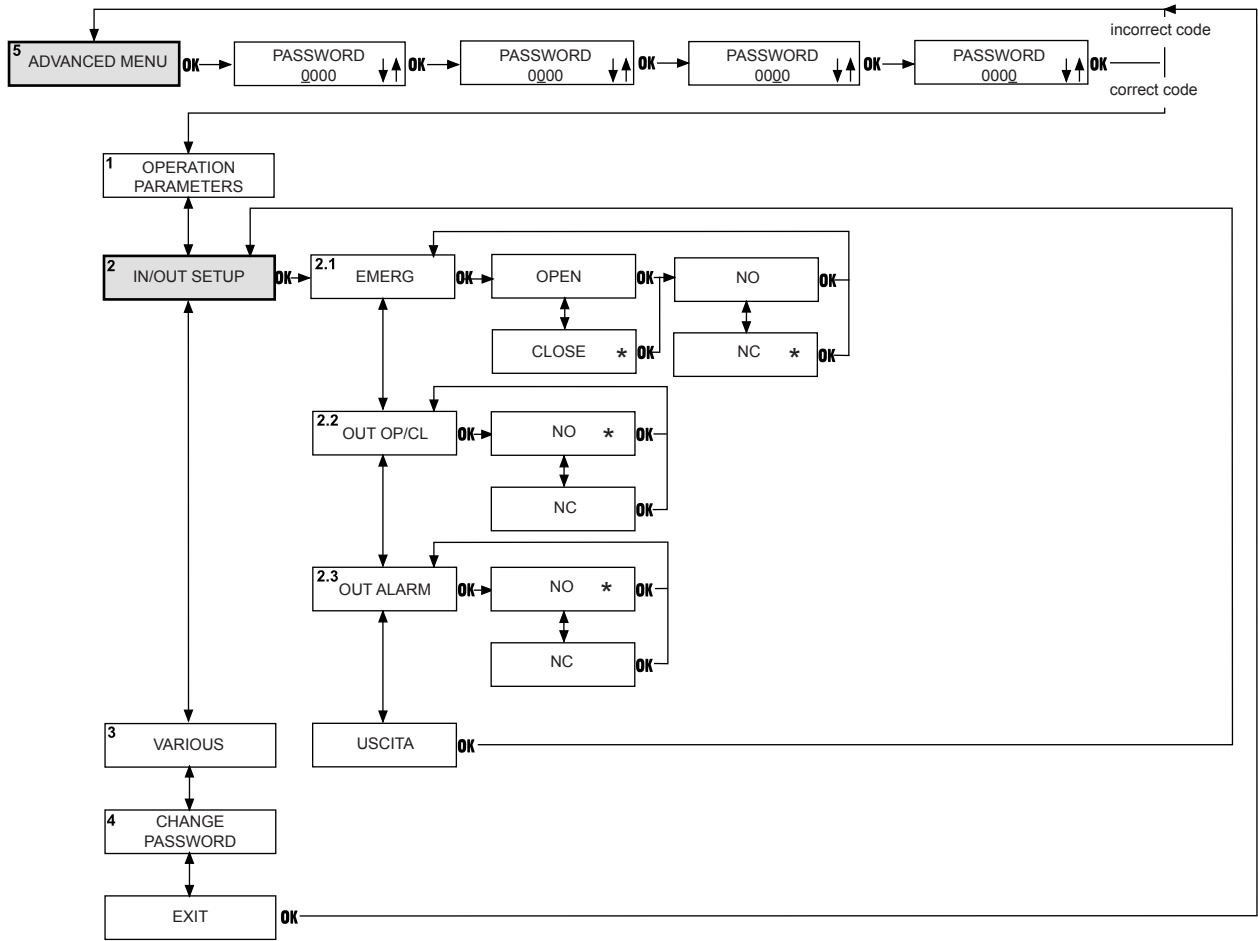


Diagram 8: Various - Change password - Test prog

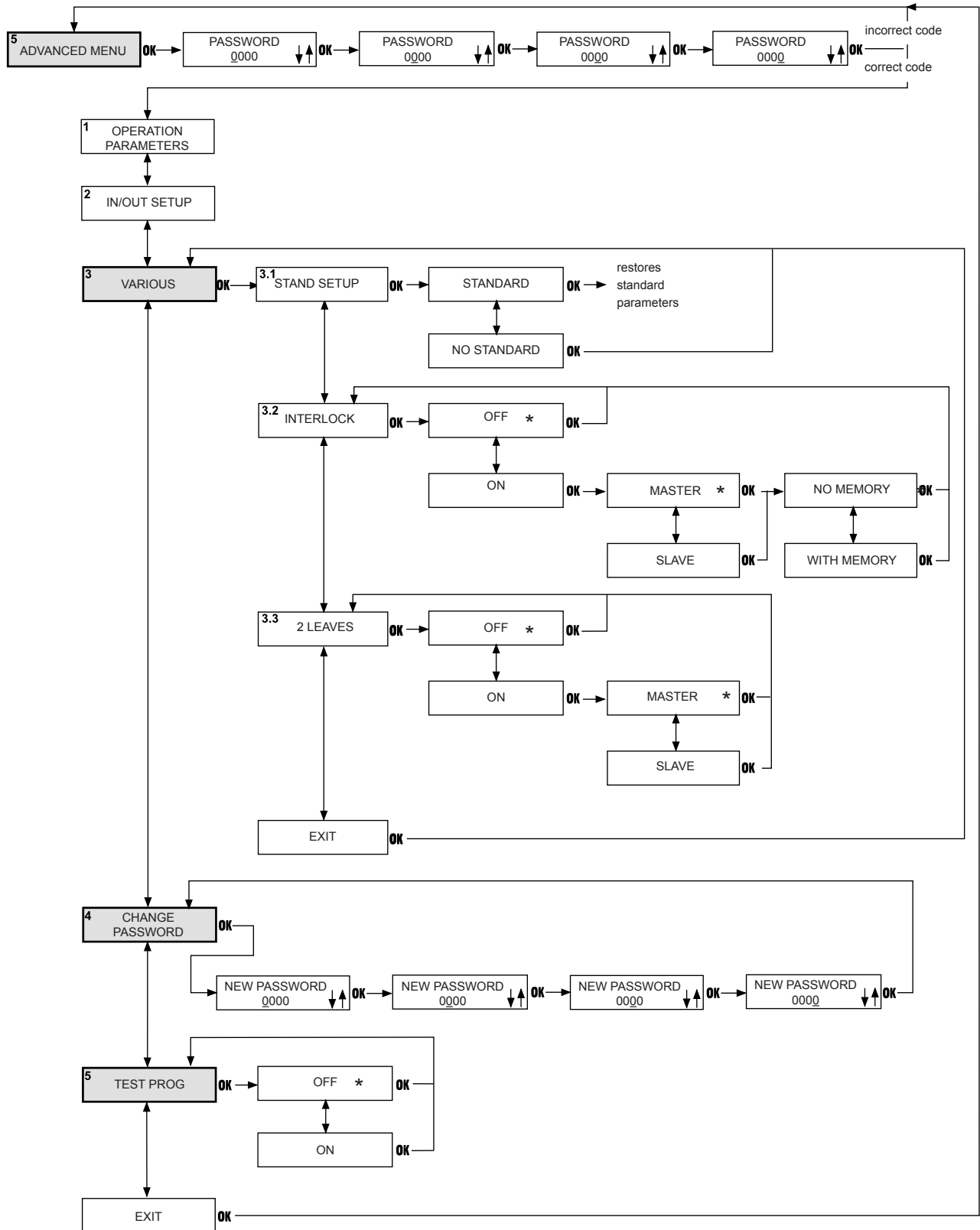


Diagramma 9: Clock

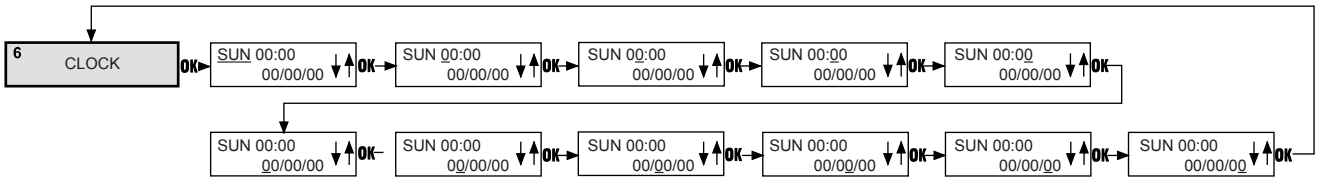


Diagram 10: Timer

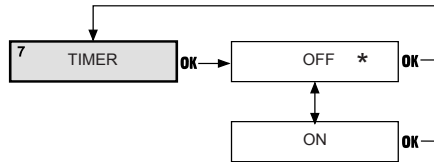
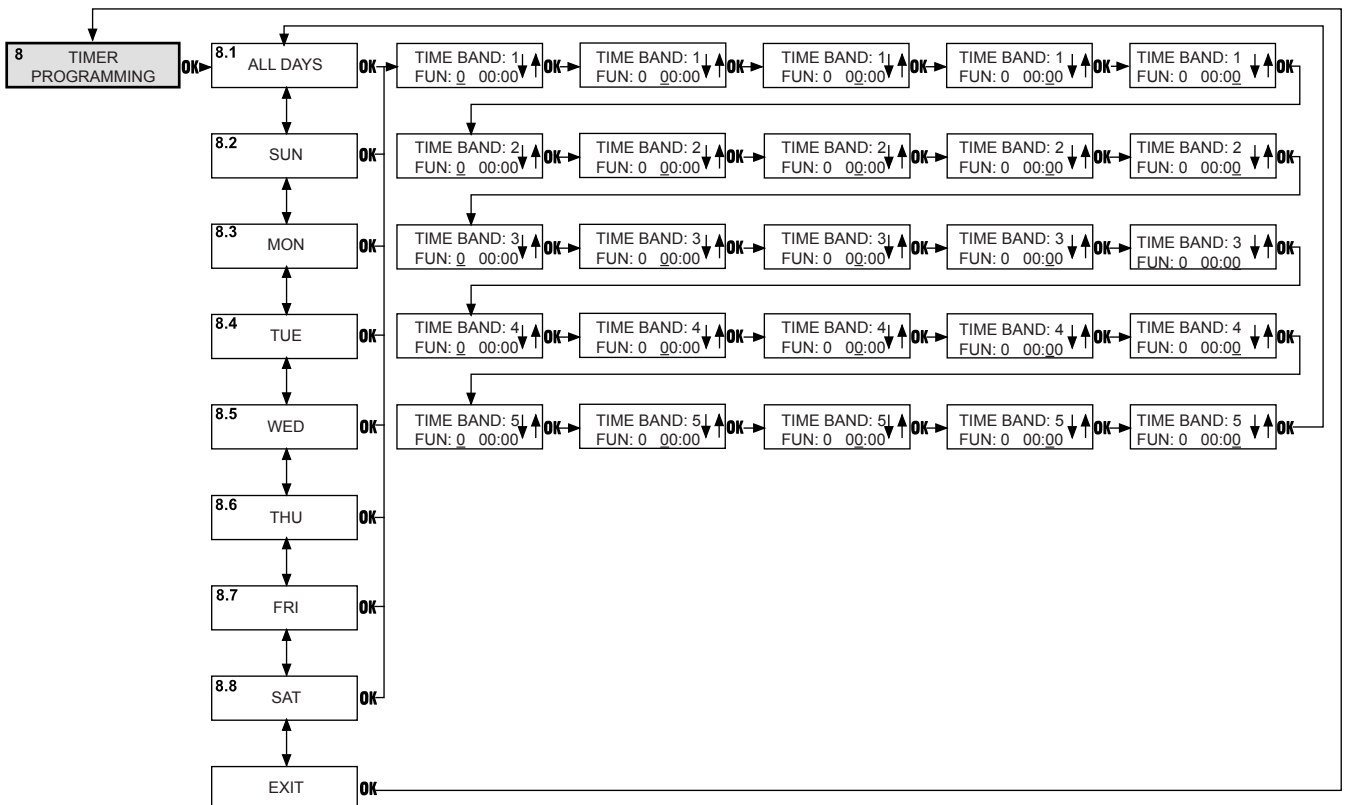


Diagram 11: Timer programming



**1 LANGUAGE (Diagram 2)**

Select the language for showing the messages on the display

**2 SETUP (Diagram 3)****2.1 PARTIAL OPENING**

Partial opening percentage

Select the opening percentage (referred to total opening) performed in the "Partial Opening" operational function.

Standard value: 80%

Adjusting range: from 60% to 100%

**2.2 PAUSE TIME**

Pause time value

Set pause time in the automatic operational function

Standard value: 2 sec.

Adjusting range: from 0 to 30 sec.

**2.3 NIGHT PAUSE TIME**

Night pause time value

Set pause time in the "night" operational function

Standard value: 7 sec.

Adjusting range: from 0 to 30 sec.

**2.4 OBSTACLE DETECTION**

Determines the behaviour of the automated system in the event of repeated obstacle detection during the same manoeuvre.

Standard

The automated system tries to complete the manoeuvre.

Non Standard

If an obstacle is detected for 3 consecutive times, the automated system stops. After removing the obstacle, the door has to be closed manually to restore normal operation

**3 LOCK (Diagram 4)****3.1 KIT LOCK**

On

Lock installed.

Night

The lock locks the door only in the "Night" operational function.

One-way+Night

The lock locks the door in the "Night" and "one-way" operational functions.

Always

The lock locks the door whenever this closes, irrespective of the set operational function.

Off

Lock not installed.

**4 DIAGNOSTICS (Diagram 5)****4.1 950**

The door's hardware model and the software of the 950 MPS and 950 I/O control boards to which KP-Controller is connected are shown.

**4.2 CYCLES No.**

The count (non resettable) of the cycles effected by the automated system is shown

**4.3 ALARM No.**

The number and description of the current alarm are shown.

Refer to table 1 for error codes and descriptions.

**RESET**

Executes reset procedure and, if the cause of signalled malfunction was removed, it restores normal operation.

**5 ADVANCED MENU****PASSWORD**

To access the advanced menu, insert the 4-digit password (default 0000).

**1 OPERATION PARAMETERS (Diagram 6)****1.1 CLOSING SPEED**

Sets door speed for closing.

Standard value: level 8

Adjusting range: from 0 to 10

**1.2 OPENING SPEED**

Sets door speed for opening.

Standard value: level 8

Adjusting range: from 0 to 10

**1.3 KEEP SETTINGS**

On

The automated system maintains the operating parameters set with KP-Controller even if this is disconnected.

Off

If the KP-Controller is disconnected, the settings of opening and closing speeds and pause time must be made using the trimmers (see Par. 5.2)

**2 IN/OUT SETUP (Diagram 7)****2.1 EMERG**

Sets the effect of the emergency command (Emerg input on 950 I/O control board).

Standard setting: Opens/NC

Open

Activating this command opens the door.

Close

Activating this command closes the door.

NO

Normally open input.

NC

Normally closed input.

**2.2 OUT OP/CL**

Sets operation of Open and Closed status outputs of 950 I/O control board

Standard setting: NO

NC

Normally closed input.

NO

Normally open input.

**2.3 OUT ALARM**

Sets operation of Alarm status outputs of 950 I/O control board

Standard setting: NO

NO

Normally open input.

NC

Normally closed input.

**3 VARIOUS (Diagram 8)****3.1 STANDARD SETUP**

Used for checking if any non-standard programming operation was effected.

Standard

If no function was modified with respect to the standard programming, an asterisk is shown.

If the asterisk is not present, press the "OK" key and all standard programming functions are reset.

Non Standard

If at least one function was modified with respect to the standard programming, an asterisk is shown.

**3.2 INTERLOCK**

The interlock function makes it possible to control two doors (master and slave) so that opening of one depends on closing of the other and vice versa.

Off

Interlock function not active.

On

Activates the interlock function.

Master

The master door (usually the internal one).

Slave

The slave door.

No Memory

With interlock operation, you must wait for one door to close before commanding the other to open: any opening pulses sent during the operating cycle of the first door, have not effect.

With Memory

With interlock operation, there is not need to wait for one door to close before commanding the other to open: any opening pulses sent during the operating cycle of the first door are memorised, and the second door opens automatically as soon as the first door closes.

3.3 2 LEAVES

The "2 LEAVES" function is used to control 2-leaf doors. The two automated systems (master and slave) synchronously control door movement. The Master function must be associated with the door which begins the opening movement first.

Off

"2 LEAVES" function not active.

On

Activates the "2 LEAVES" function.

Master

The master door (if the leaves have an overlap, it is always the first to start the opening movement).

Slave

The slave door.

**4 CHANGE PASSWORD**

Sets the new password for accessing (4 digits) the advanced menu. Default 0000.

**5 TEST PROG.**

Runs an operational test of the automated system. If a malfunction is detected, the system stops and the KP-Controller signals the detected malfunction status.

Off

Test function not active.

On

Activates the test function.

**6 CLOCK (Diagram 9)**

Sets the current day, time and date.

**7 TIMER (Diagram10)**

Off

Timer not activated.

On

Timer activated: the operating time bands set in "8 Timer Programming" are enabled.

When the timer is activated, a "T" appears at the side of the time shown on the display and the KP-Controller will not allow any operational selection.

The battery inside the KP-Controller maintains the clock in operation even if power is not supplied; if correct time is lost (e.g. black-out and discharged battery), a flashing asterisk appears in place of the "T", the timer is disabled and the system automatically commutates into the NIGHT function.

**8 TIMER PROGRAMMING (Diagram 11)**

With the timer, you can create up to 5 different time bands for each day of the week (by setting the band starting time) and assign an operational function to each time band.

When the KP-Controller's internal clock reaches the starting time of a band, the associated operating function is automatically set, and the door remains in this condition until the subsequent band intervenes.

Permanent connection of the KP-Controller+Display is necessary for correct management of time bands.

Selecting the day

Selects the day of the week to create time bands.

If you select "All days", any time bands defined subsequently are included in all days of the week.

Function

Sets the operating function to be associated with the time band by referring to the following table:

FUN	MEANING
0	NO FUNCTION
1	AUTOMATIC BI-DIRECTIONAL TOTAL
2	AUTOMATIC ONE WAY TOTAL
3	AUTOMATIC BI-DIRECTIONAL PARTIAL
4	AUTOMATIC ONE WAY PARTIAL
5	DOOR TOTALLY OPEN
6	DOOR PARTIALLY OPEN
7	MANUAL
8	NIGHT

Time band starting time

Sets the activation time for the time band.

There is no need for the time bands to be in chronological order.

-Programming example -

We wish to program a door operating at the following times:

•from MONDAY to FRIDAY:

- from 8 a.m. in AUTOMATIC BI-DIRECTIONAL TOTAL

- from 6 p.m. in AUTOMATIC ONE WAY TOTAL

- from 7 p.m. in NIGHT

•SATURDAY and SUNDAY: NIGHT for the whole day

Proceed as follows:

select ALL DAYS and set the following:

TIME BAND 1 : FUN 1 08:00

TIME BAND 2 : FUN 2 06:00 p.m.

TIME BAND 3 : FUN 8 07:00 p.m.

TIME BAND 4 : FUN 0

TIME BAND 5 : FUN 0

Select SATURDAY and set the following:

TIME BAND 1 : FUN 0

TIME BAND 2 : FUN 0

TIME BAND 3 : FUN 0

TIME BAND 4 : FUN 0

TIME BAND 5 : FUN 0

Select SUNDAY and set the following:

TIME BAND 1 : FUN 0

TIME BAND 2 : FUN 0

TIME BAND 3 : FUN 0

TIME BAND 4 : FUN 0

TIME BAND 5 : FUN 0

Note: for correct use of the TIMER function, the battery of the KP-Controller must be efficient. In case of a power cut, the battery keeps the clock in operation. If the battery is discharged, the clock resets and, when power is restored, the KP-Controller automatically switches to NIGHT.

For automated systems which are not powered for long periods (e.g. 12 hours out of 24 for 365 days a year), we advise you to replace the battery not later than every 3 years.

**11. SPECIAL APPLICATIONS**

**11.1. INTERLOCK**

The interlock function makes it possible to control two doors (master and slave) so that opening of one depends on closing of the other and vice versa.

**11.1.1. INTERLOCK WITH INTERNAL SENSORS**

This application is recommended when the distance between the two doors is sufficient to avoid interference in the detection ranges of the two internal sensors.

- Make the connections between the 950I/O control units of the two automated systems and the sensors as shown in figure 28.
- Program the following functions (see advanced progr.):
  - “interlock” active on both doors,
  - select the “MASTER” option for the internal door, and the “SLAVE” option for the external one,
  - select, for both doors, option “interlock without memory” or “interlock with memory”.

Important:

- The sensors must be connected only to the Key input of the control units;
- The interlock will operate only if both doors are set to the NIGHT or ONE-WAY operating function.

Operation

These are the interlock operational stages:

- 1) The person on the outside activates sensor S1 of door A;
- 2) Door A opens;
- 3) The person enters the internal space between the two doors;
- 4) Door A closes after the night pause time elapses;
- 5) The person activates sensor S3 of door B (If the “Interlock with memory” option was selected, there is no need to wait for the first door to close totally in order to activate the sensor of the second door);
- 6) Door B opens;

7) The person exits;

8) Door B closes after the night pause time elapses.

The operation is identical if the person comes from the opposite direction.

**11.1.2. INTERLOCK WITHOUT INTERNAL SENSORS**

This application is recommended if the doors are so near to one another that the two internal sensors cannot be used; two pushbuttons have to be installed for activating the doors from the outside; no presence sensors are used.

•Make the connections between the 950I/O control units of the two automated systems, of the pushbuttons and additional electronic components as shown in figure 29.

•Program the following functions (see advanced progr.):

- “interlock” active on both doors,
- select the “MASTER” option for the internal door, and the “SLAVE” option for the external one,
- select the “interlock with memory” option for both doors.

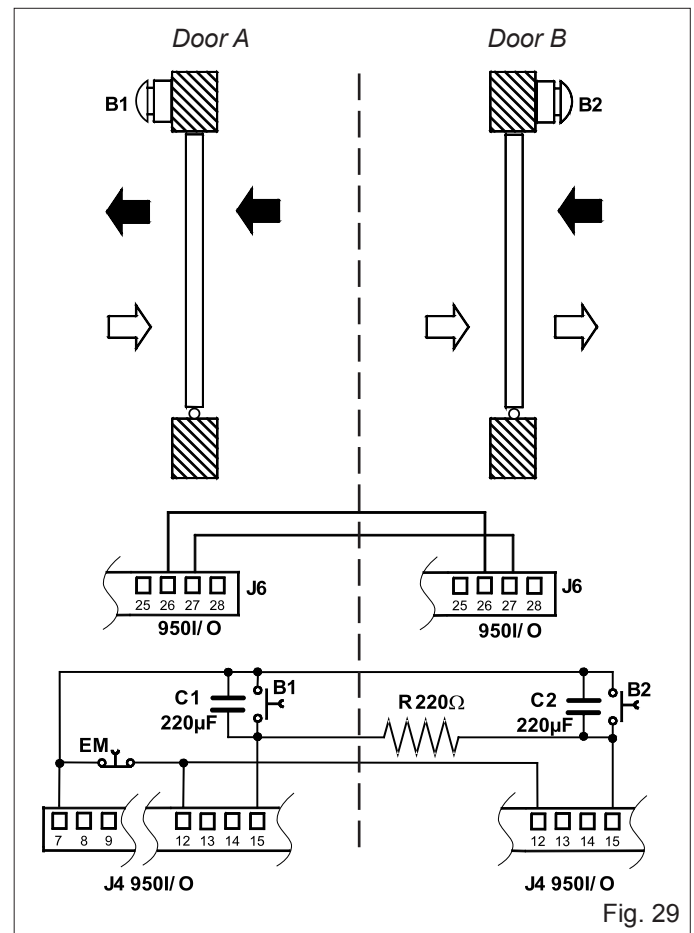
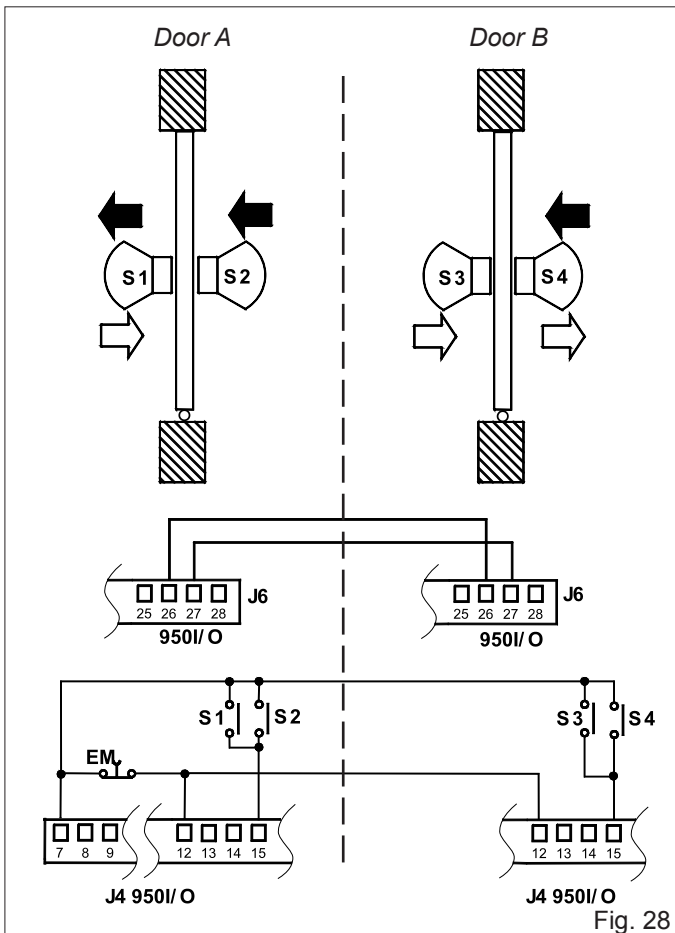
Important:

- The pushbuttons must be connected only to the Key input of the control units;
- The interlock will operate only if both doors are set to the NIGHT or ONE-WAY operating function.

Operation

These are the interlock operational stages:

- 1) The person on the outside activates pushbutton B1 of door A;
  - 2) Door A opens;
  - 3) The person enters the internal space between the two doors;
  - 4) Door A closes after the night pause time elapses;
  - 5) Door B opens automatically;
  - 7) The person exits;
  - 8) Door B closes after the night pause time elapses.
- The operation is identical if the person comes from the opposite direction.





11.2. 2 LEAVES

The "2 LEAVES" function makes it possible to manage two opposing doors with a synchronised movement and preset delay angles (these cannot be modified).

The leaf controlled by the master automated system (see fig. 30) is the first to start the opening movement and, when it has reached the opening angle preset for leaf delay, the slave leaf begins its movement too.

Likewise, when closing, the master begins to move only when the slave has reached the closing angle preset for leaf delay.

If one of the automated systems detects an obstacle, the movement of both leaves is immediately reversed.

The partial opening function enables control of total opening of the master only.

The operating functions must be set on the master automated system only (or on the KP-Controller if connected).

- Make the connections between the 950I/O control unit of the two automated systems as shown in fig. 31.
- Connect all sensors and pulse generators to the master only.
- Program the following functions (see advanced programming):
  - "2 LEAVES" active on both doors;
  - Select the "MASTER" option for the door due to begin the opening movement first, and select "SLAVE" for the other door.
  - Set the same motion parameters on the two automated systems;
  - If you wish to disconnect the KP-Controller from the slave door, you have to set function "KEEP SETTINGS" to ON;

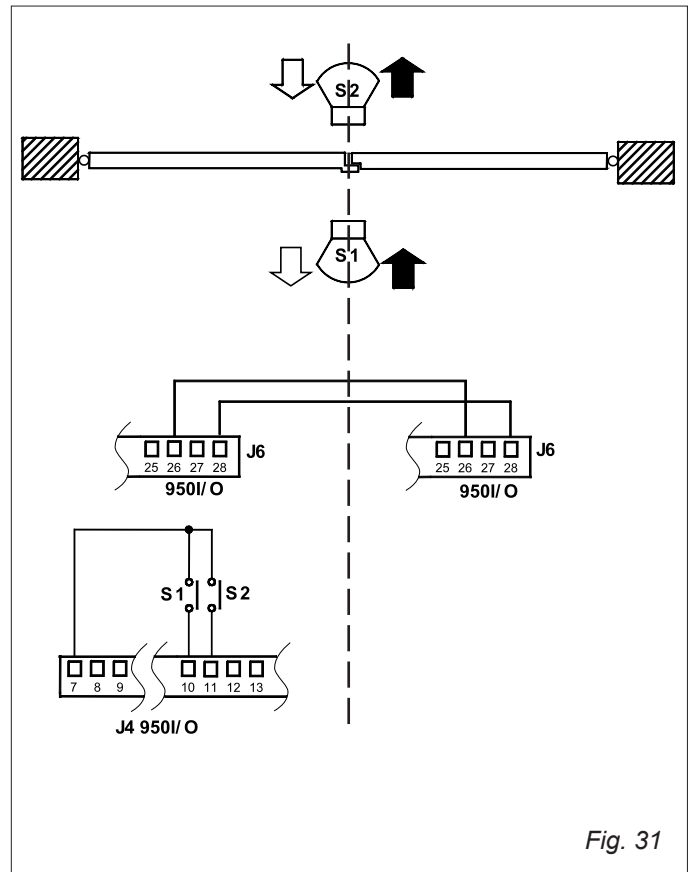


Fig. 31

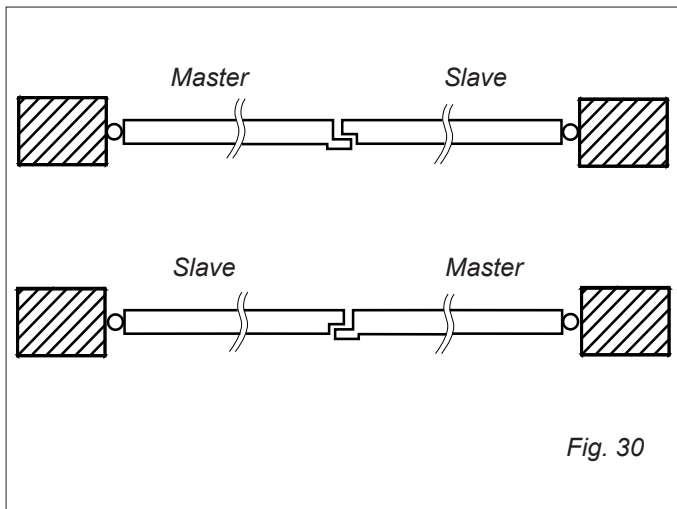


Fig. 30

## TROUBLESHOOTING

PROBLEM	SUGGESTION
Operator will not run the setup cycle	<ol style="list-style-type: none"> <li>1. Check that LED 5, 6 &amp; 7 are ON These LED's show safety and stop circuits. Refer to page 6 "installing jumpers" for more information.</li> <li>2. Insure that you hold down the setup button for a minimum of 5 seconds Refer to page 6 "running the setup cycle" for more information.</li> </ol>
Door will not automatically close	<ol style="list-style-type: none"> <li>1. Check that LED 2, 3, 4 &amp; 8 are OFF These LEDs show activation inputs, if an LED is ON check the associated input to the LED and test devices or refer to the activation device manual.</li> <li>2. Check that LED 5, 6 &amp; 7 are ON These LED's show safety and stop circuits. Refer to page 6 "installing jumpers" for more information.</li> </ol>
Door will not open	<ol style="list-style-type: none"> <li>1. Check that LED 5, 6 &amp; 7 are ON These LED's show safety and stop circuits. Refer to page 6 "installing jumpers" for more information.</li> <li>2. Check the activation device to see if the corresponding LED goes ON</li> </ol>
Door is hard to open manually	<ol style="list-style-type: none"> <li>1. Reduce spring tension Refer to page 5 "adjusting the spring".</li> </ol>
Door will not reach it's full closed position	<ol style="list-style-type: none"> <li>1. Check the stop position against the closed position of the door Refer to page 5 "adjusting the stops".</li> <li>2. Reduce spring tension Refer to page 5 "adjusting the spring".</li> </ol>
I see a flashing red LED	<ol style="list-style-type: none"> <li>1. This is showing you an alarm condition, please refer to the complete manual.</li> </ol>

**LIMITED WARRANTY**

To the original purchaser only:

FAAC International, Inc., warrants, for twenty-four (24) months from the date of invoice, the gate operator systems and other related systems and equipment manufactured by FAAC S.p.A. and distributed by FAAC International, Inc., to be free from defects in material and workmanship under normal use and service for which it was intended provided it has been properly installed and operated.

FAAC International, Inc.'s obligations under this warranty shall be limited to the repair or exchange of any part of parts manufactured by FAAC S.p.A. and distributed by FAAC International, Inc. Defective products must be returned to FAAC International, Inc., freight prepaid by purchaser, within the warranty period. Items returned will be repaired or replaced, at FAAC International, Inc.'s option, upon an examination of the product by FAAC International, Inc., which discloses, to the satisfaction of FAAC International, Inc., that the item is defective. FAAC International, Inc. will return the warranted item freight prepaid. The products manufactured by FAAC S.p.A. and distributed by FAAC International, Inc., are not warranted to meet the specific requirements, if any, of safety codes of any particular state, municipality, or other jurisdiction, and neither FAAC S.p.A. or FAAC International, Inc., assume any risk or liability whatsoever resulting from the use thereof, whether used singly or in combination with other machines or apparatus.

Any products and parts not manufactured by FAAC S.p.A. and distributed by FAAC International, Inc., will carry only the warranty, if any, of the manufacturer. This warranty shall not apply to any products or parts thereof which have been repaired or altered, without FAAC International, Inc.'s written consent, outside of FAAC International, Inc.'s workshop, or altered in any way so as, in the judgment of FAAC International, Inc., to affect adversely the stability or reliability of the product(s) or has been subject to misuse, negligence, or accident, or has not been operated in accordance with FAAC International, Inc.'s or FAAC S.p.A.'s instructions or has been operated under conditions more severe than, or otherwise exceeding, those set forth in the specifications for such product(s). Neither FAAC S.p.A. nor FAAC International, Inc., shall be liable for any loss or damage whatsoever resulting, directly or indirectly, from the use or loss of use of the product(s). Without limiting the foregoing, this exclusion from

liability embraces a purchaser's expenses for downtime or for making up downtime, damages for which the purchaser may be liable to other persons, damages to property, and injury to or death of any persons.

FAAC S.p.A. or FAAC International, Inc., neither assumes nor authorizes any person to assume for them any other liability in connection with the sale or use of the products of FAAC S.p.A. or FAAC International, Inc. The warranty herein above set forth shall not be deemed to cover maintenance parts, including, but not limited to, hydraulic oil, filters, or the like. No agreement to replace or repair shall constitute an admission by FAAC S.p.A. or FAAC International, Inc., of any legal responsibility to effect such replacement, to make such repair, or otherwise. This limited warranty extends only to wholesale customers who buy directly through FAAC International, Inc.'s normal distribution channels. FAAC International, Inc., does not warrant its products to end consumers.

Consumers must inquire from their selling dealer as to the nature and extent of that dealer's warranty, if any. This warranty is expressly in lieu of all other warranties expressed or implied including the warranties of merchantability and fitness for use. This warranty shall not apply to products or any part thereof which have been subject to accident, negligence, alteration, abuse, or misuse or if damage was due to improper installation or use of improper power source, or if damage was caused by fire, flood, lightning, electrical power surge, explosion, wind storm, hail, aircraft or vehicles, vandalism, riot or civil commotion, or acts of God.