

B680H

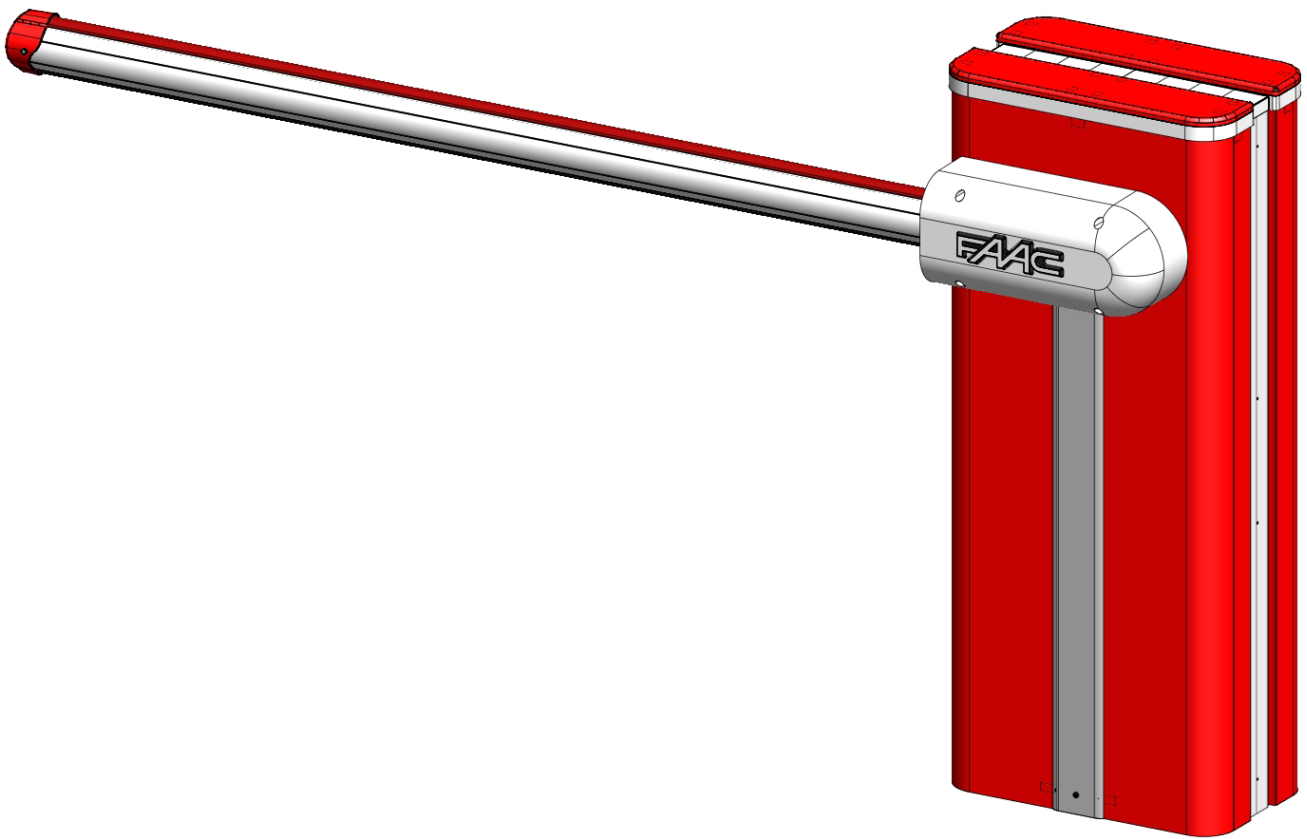

www.FastGateOpeners.com | (800) 878-7829 | Sales@FastGateOpeners.com

FAAC

TABLE OF CONTENTS

B680H BARRIER GATE OPERATOR

1. TECHNICAL SPECIFICATIONS 6

2. ELECTRICAL LAYOUT 7

3. DIMENSIONS 7

4. INSTALLING THE OPERATOR 7

 4.1 Preliminary checks 7

 4.2 Install the foundation plate 7

 4.3 Mechanical installation 7

 4.5 Balancing the Beam 12

5. MANUAL OPERATION 12

 5.1 Restore normal operations 12

6. POWER CONNECTION 12

7. FIELD INSTALL LABELS 13

8. REVERSING THE OPENING DIRECTION 13

9. MAINTENANCE 13

 8.1 Topping up the oil 13

 8.2 Air bleeding 13

10. INSTALL THE BEAM LIGHTS 14

11. INSTALL THE COVER 15

12. SPARE PARTS 16

E680 CONTROL BOARD

1. WARNINGS 18

2. DESCRIPTION OF THE COMPONENTS 18

3. TECHNICAL SPECIFICATIONS 18

4. ELECTRICAL CONNECTIONS 19

 4.1 Terminal board J1 (inputs) 19

 4.2 Terminal board J2 (outputs) 20

 4.3 Terminal board J3 (external flashing lamp) 20

 4.4 Terminal board J4 (loop detector) 20

 4.5 Connector J5 (Motor) 20

 4.6 Connector J7 (Encoder) 20

 4.7 Connector J10 (Radio) 20

 4.8 Connector J11 (Beam break-out sensor) 20

 4.9 Connector J12 (Emergency battery) 20

 4.10 Connector J13 (36VDC Power Supply) 20

 4.11 Connector J15 (flashing traffic light) 20

 4.12 Connector J16 (arm lights) 21

5. PROGRAMMING 21

 5.1 Basic configuration 21

 5.2 Changing the predefined parameters set 22

 5.3 Default Selection Tables 23

6. Advanced Configuration 24

 6.1 Configuring the loop detector 25

 6.2 Expert Configuration 26

 6.3 Pre-Defined Parameter Sets 29

 6.4 "Expert" default parameters 30

7. START-UP 30

 7.1 Verifying the diagnostic LEDs 30

 7.2 Setup 30

8. TESTING THE AUTOMATED SYSTEM 30

9. MASTER/SLAVE CONFIGURATION 31

10. INTERLOCK 32

11. OPERATING LOGICS TABLE 33

IMPORTANT SAFETY INFORMATION

Important Safety Instructions

WARNING - TO REDUCE THE RISK OF SEVERE INJURY OR DEATH:

- READ AND FOLLOW ALL INSTRUCTIONS.
- Never let children operate or play with the gate controls. Keep remote controls away from children.
- Always keep people and objects away from the gate. NO ONE SHOULD CROSS THE PATH OF A MOVING GATE.
- Test the gate operator monthly. The gate MUST reverse on contact with a rigid object or when an object activates a non-contact sensor. If necessary, adjust the force or the limit of travel and then retest the gate operator. Failure to properly adjust and retest the gate operator can increase the risk of injury or death.
- Use the manual release mechanism only when the gate is not moving.
- KEEP GATE PROPERLY MAINTAINED. Have a qualified service person make repairs to gate hardware.
- The entrance is for vehicles only. Pedestrians must use a separate entrance.
- SAVE THESE INSTRUCTIONS.

Important Installation Instructions

1. Install the gate operator only when the following conditions have been met:
 - The operator is appropriate for the type and usage class of the gate.
 - All openings of a horizontal slide gate have been guarded or screened from the bottom of the gate to a minimum of 4 feet (1.25 m) above the ground to prevent a 2.25 inch (55 mm) diameter sphere from passing through openings anywhere in the gate or through that portion of the adjacent fence that the gate covers when in the open position.
 - All exposed pinch points are eliminated or guarded.
 - Guarding is supplied for exposed rollers.
2. The operator is intended for installation on gates used by vehicles only. Pedestrians must be provided with a separate access opening.
3. To reduce the risk of entrapment when opening and closing, the gate must be installed in a location that allows adequate clearance between the gate and adjacent structures. Swinging gates shall not open outward into public access areas.
4. Before installing the gate operator, ensure that the gate has been properly installed and that it swings freely in both directions. Do not over-tighten the operator clutch or pressure relief valve to compensate for a damaged gate.
5. User controls must be installed at least 6 feet (1.83 m) away from any moving part of the gate and located where the user is prevented from reaching over, under, around or through the gate to operate the controls. Controls located outdoors or those that are easily accessible shall have security features to prevent unauthorized use.
6. The Stop and/or Reset buttons must be located within line-of-sight of the gate. Activation of the reset control shall not cause the operator to start.
7. All warning signs and placards must be installed and easily seen within visible proximity of the gate. A minimum of one warning sign shall be installed on each side of the gate.
8. For gate operators that utilize a non-contact sensor (photo arm or the like):
 - See instructions on the placement of non-contact sensors for each type of application.
 - Exercise care to reduce the risk of nuisance tripping, such as when a vehicle trips the sensor while the gate is still moving.
 - Locate one or more non-contact sensors where the risk of entrapment or obstruction exists, such as at the reachable perimeter of a moving gate or barrier.
 - Use only FAAC "Photoarm" photoelectric eyes to comply with UL325.

Important Installation Instructions (continued)

9. For gate operators that utilize a contact sensor (edge sensor or similar):
 - Locate one or more contact sensors where the risk of entrapment or obstruction exists, such as at the leading edge, trailing edge, and post mounted both inside and outside of a vehicular horizontal slide gate
 - Locate one or more contact sensors at the bottom edge of a vehicular vertical lift gate.
 - Locate one or more contact sensors at the bottom edge of a vertical barrier (arm).
 - Locate one or more contact sensors at the pinch point of a vehicular vertical pivot gate.
 - Locate hard-wired contact sensors and wiring so that communication between sensor and gate operator is not subjected to mechanical damage.
 - Locate wireless contact sensors, such as those that transmit radio frequency (RF) signals, where the transmission of signals are not obstructed or impeded by building structures, natural landscaping or similar hindrances. Wireless contact sensors shall function under their intended end-use conditions.
 - Use only FAAC CN60E edge sensor.



General Safety Precautions

Gate Construction

Vehicular gates should be constructed and installed in accordance with ASTM F2200: Standard Specification for Automated Vehicular Gate Construction.

For more information, contact ASTM at: www.astm.org

Installation

- If you have any questions or concerns regarding the safety of the gate operating system, do not install the operator and consult the manufacturer.
- The condition of the gate structure itself directly affects the reliability and safety of the gate operator.
- Only qualified personnel should install this equipment. Failure to meet this requirement could cause severe injury and/or death, for which the manufacturer cannot be held responsible.
- The installer must provide a main power switch that meets all applicable safety regulations.
- It is extremely unsafe to compensate for a damaged gate by increasing hydraulic pressure.
- Install devices such as reversing edges and photo arms to provide better protection for personal property and pedestrians. Install reversing devices that are appropriate to the gate design and application.
- Before applying electrical power, ensure that voltage requirements of the equipment correspond to the supply voltage. Refer to the label on your gate operator system.

Usage

- Use this equipment only in the capacity for which it was designed. Any use other than that stated should be considered improper and therefore dangerous.
- The manufacturer cannot be held responsible for damage caused by improper, erroneous or unreasonable use.
- If a gate system component malfunctions, disconnect the main power before attempting to repair it.
- Do not impede the movement of the gate, you may injure yourself or damage the gate system as a result.
- This equipment may reach high thermal temperatures during normal operation, therefore use caution when touching the external housing of the gate operator.
- Use the manual release mechanism according to the procedures presented in this manual.
- Before performing any cleaning or maintenance operations, disconnect power to the equipment.
- All cleaning, maintenance or repair work must be performed by qualified personnel.

UL325 Gate Operator Classifications

RESIDENTIAL VEHICULAR GATE OPERATOR CLASS I

A vehicular gate operator system intended for use in a single family dwelling, garage or associated parking area.

COMMERCIAL / GENERAL ACCESS VEHICULAR GATE OPERATOR CLASS II

A vehicular gate operator system intended for use in commercial locations or buildings such as multi-family housing units (five or more single family units), hotels, parking garages, retail stores or other buildings that service the general public.

INDUSTRIAL / LIMITED ACCESS VEHICULAR GATE OPERATOR CLASS III

A vehicular gate operator system intended for use in industrial locations or buildings such as factories, loading docks or other locations not intended to service the general public.

RESTRICTED ACCESS VEHICULAR GATE OPERATOR CLASS IV

A vehicular gate operator system intended for use in guarded industrial locations or buildings such as airport security areas or other restricted access locations that do not service the general public, and in which unauthorized access is prevented via supervision by security personnel.

B680H BARRIER GATE OPERATOR

The B680H barrier gate operator system consists of a white aluminium arm with reflectors and optional lights, a steel upright profile and a metal cover. The operator is mounted on the upright profile and it's made with a hydraulic unit and two plunging pistons connected to it, which, by means of a rocker arm, rotate the arm. The arm weight is balanced with a spring fitted on one of the two plunging pistons. The electronic control equipment is also housed on the upright profile, inside a transparent plastic compartment. The whole operator is protected by the external metal cover.

The system features an adjustable electronic anti-crushing safety, a device that guarantees stopping and locking of the arm in any position, and a convenient manual release for use in case of power outage or malfunction.

1. TECHNICAL SPECIFICATIONS

Main AC supply	100-240 Vac / 50-60Hz
Electric Motor	36Vdc Brushless
Power rating	240W
Current rating	1.1A at 230 Vac
Motor rotation speed	1000-6000 rpm
Pump flow capacity	3,2 l/min (max)
Yielded torque	0-273 lbf.ft (0-370 Nm)
Oil type	FAAC HP OIL
Oil quantity	1.27 Qt (1.2 Lt)
Anti-crushing System	Electronic with absolute encoder
Deceleration type	Electronic with absolute encoder
Operating ambient temperature	-4 °F +131 °F (-20 °C +55 °C)
Rated Operating Time (ROT)	Continuous Duty at 131 °F (55 °C)
Surface protection treatment	EP SL LF PRIMER
Arm type	Rounded with lights and rubber bumper
Protection Class	IP56
Weight (body + cover)	143+44 lb (65+20 Kg)
Opening and closing times including deceleration	1.5 s - 7.5 ft (2.3m) arm 6.0 s - 27 ft (8.3m) arm

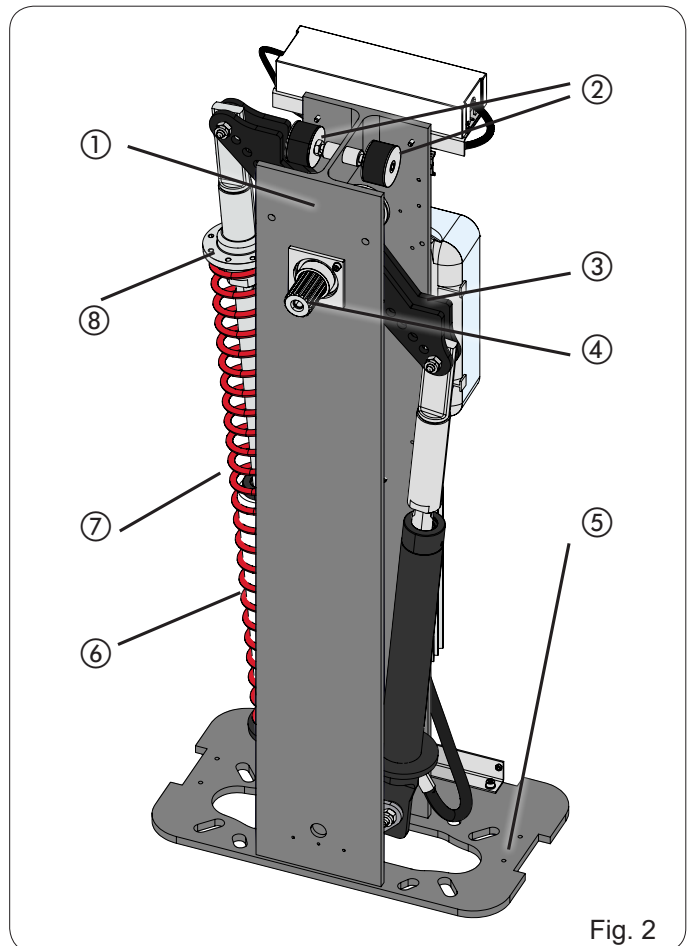
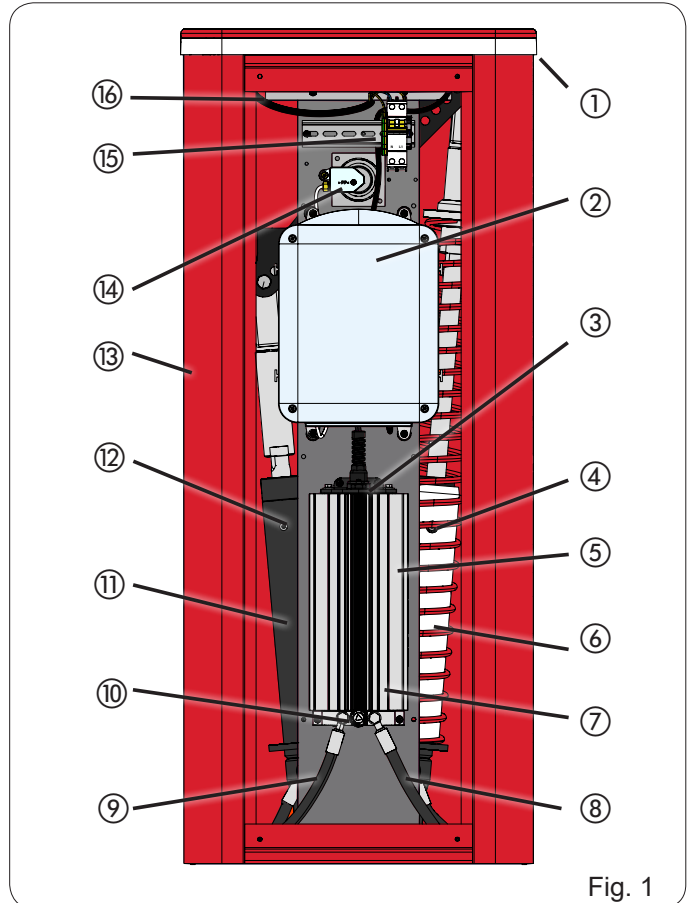

Fig. 1 References

① Built-in flashing lamp	⑨ Left hydraulic hose
② Electronic control board	⑩ Release lock
③ Oil filling cap	⑪ Left plunging piston
④ Right piston bleeder screw	⑫ Left piston bleeder screw
⑤ Hydraulic unit	⑬ Cover
⑥ Right plunging piston	⑭ Encoder
⑦ Built in heatsink	⑮ Power Switch
⑧ Right hydraulic hose	⑯ Switching power supply

Fig. 2 References

① Support structure	⑤ Mounting plate
② Mechanical stops	⑥ Spring guide
③ Rocker arm	⑦ Balance spring
④ Drive shaft	⑧ Preload adjustment ring nut

2. ELECTRICAL LAYOUT

Following the instructions shown in Fig. 3, prepare the conduits to make all the control board electrical connections with the chosen accessories.

Always separate the AC power cables from the control and safety cables (button, receiver, photocells, etc.).

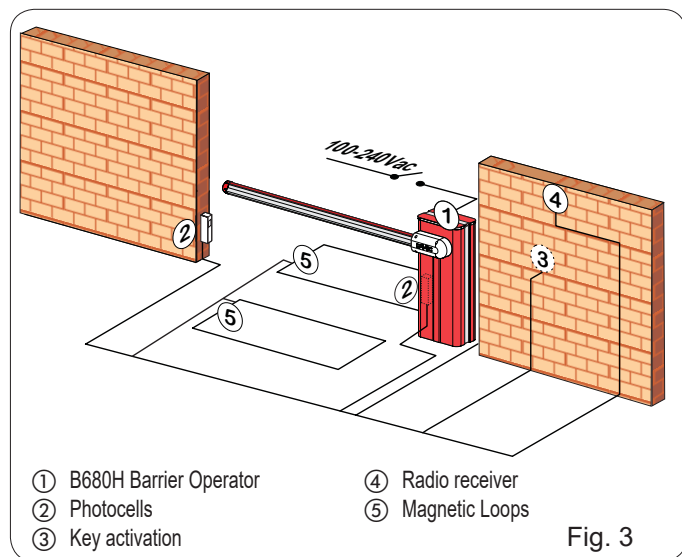

3. DIMENSIONS

For barrier dimensions, refer to Fig. 4. The cover size is the same for both models, while the arm dimensions differ as shown in detail at ① (bar S) and ② (bar L)

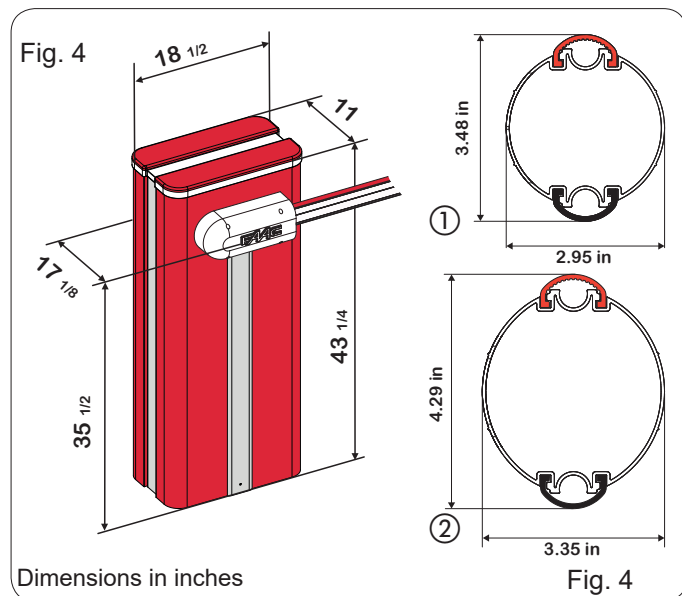

4. INSTALLING THE OPERATOR

4.1 Preliminary checks

For the safety and correct operation, make sure that the following conditions are met:

- When in motion, the arm must not encounter obstacles or power cables.
- The characteristics of the ground must guarantee sufficient solidity of the concrete foundation.
- No pipes or electrical cables should be present in the foundation digging area.

- If the barrier body is exposed to vehicle transit, provide for adequate protection against accidental impact, when possible.
- Ensure that there is an available and good earth ground connection.



Position the foundation plate so as to allow easy access to the barrier door. The foundation pad must be installed keeping in mind the characteristics of the ground to ensure perfect stability of the operator.

4.2 Install the foundation plate

- Assemble the foundation plate as shown in Fig. 5 ref. ①
- Build a concrete pad as shown in Fig. 5 ref. ②
- Set the foundation plate as shown in Fig. 5 ref. ② providing for one or more conduits for the passage of the electrical cables.



For dimensional reasons, the cable conduits must be placed on one side of the space provided at the base of the barrier (see Fig. 5).

- Use a level to ensure that the plate is perfectly horizontal.
- Wait for the concrete to cure.

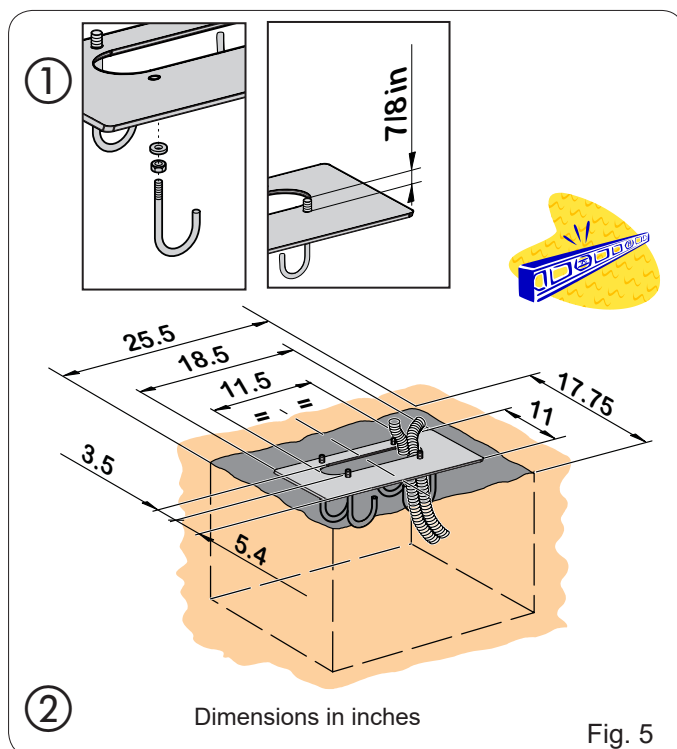

4.3 Mechanical installation

- Fix the upright profile on the foundation plate using the four provided nuts (Fig. 6). Remember that the hydraulic unit must usually face the inside of the property, unless a swing-away bracket is used. In that case install the barrier so that the swing-away follows the direction of traffic.

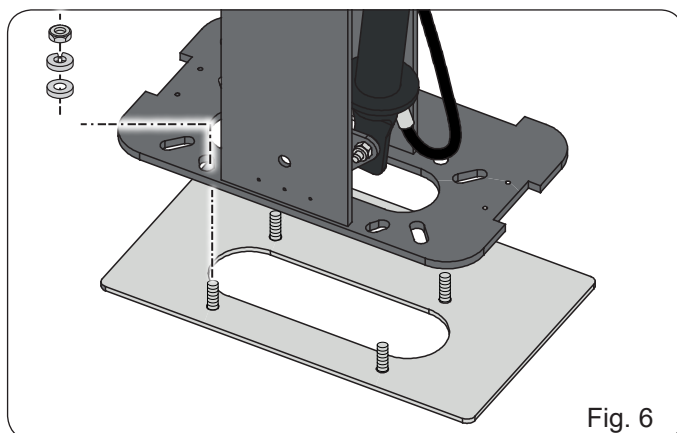

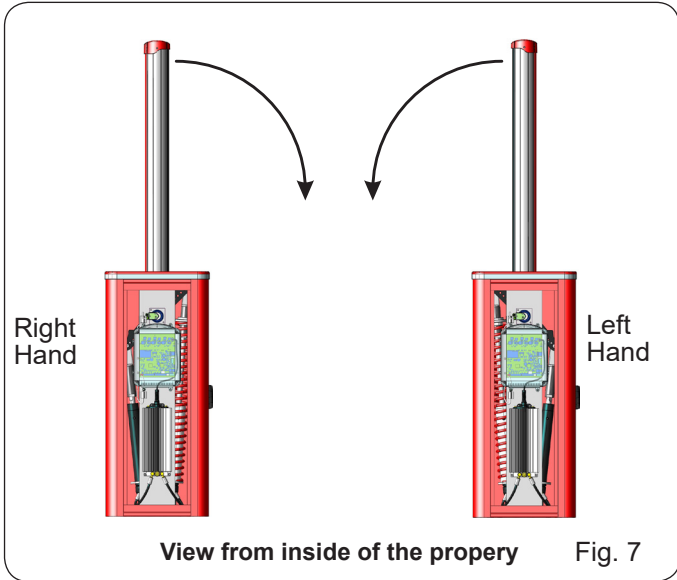

- Set the operator in manual mode, as shown in paragraph 5 - Manual Operation.
- Remove and set aside the vent screw, as shown in Fig. 8 ref. ②.

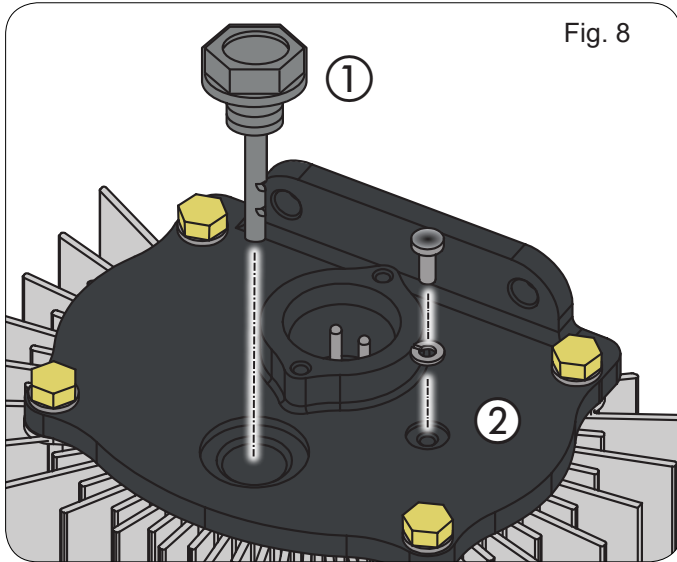

- Set the rocker arm horizontally, then remove, as shown in Fig. 9 ref. ①, the upper bolt of the piston on the arm side and insert the spring guide and balance spring on it, as shown in Fig. 10 ref. ②, followed by the tension adjustment ring nut, paying attention to the direction it must be inserted in (see Fig. 10 ref. ①).

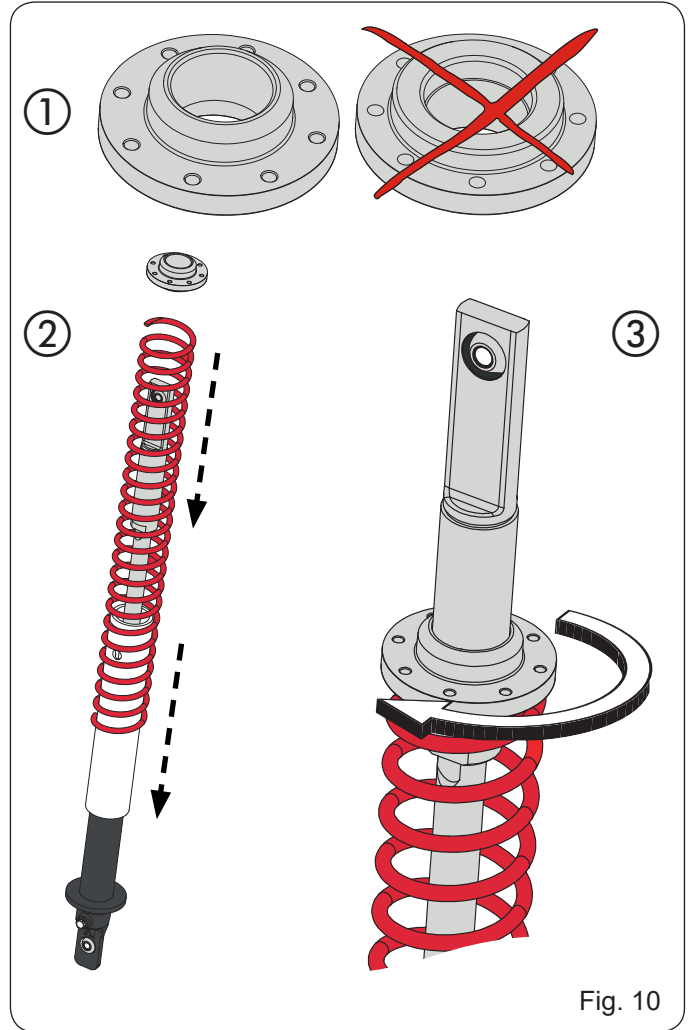
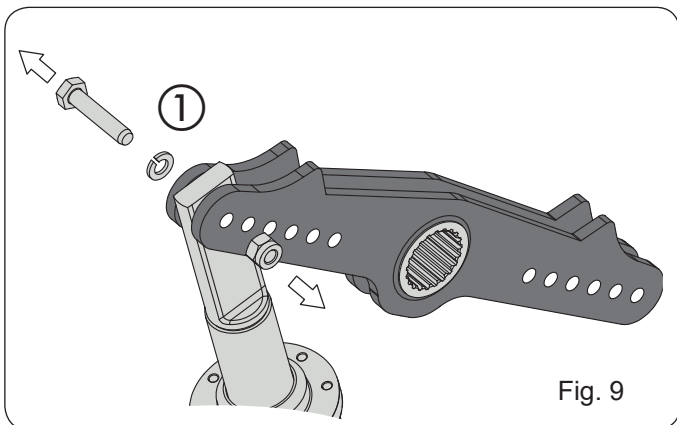

- Identify, as described in Table 1 / Table 2 on the following page, the correct fastening hole for the piston, then reinsert the bolt and tighten the nut.
- Fasten the piston on the opposite side in the same manner

NOTE: With the barrier open, the spring must NOT be compressed.

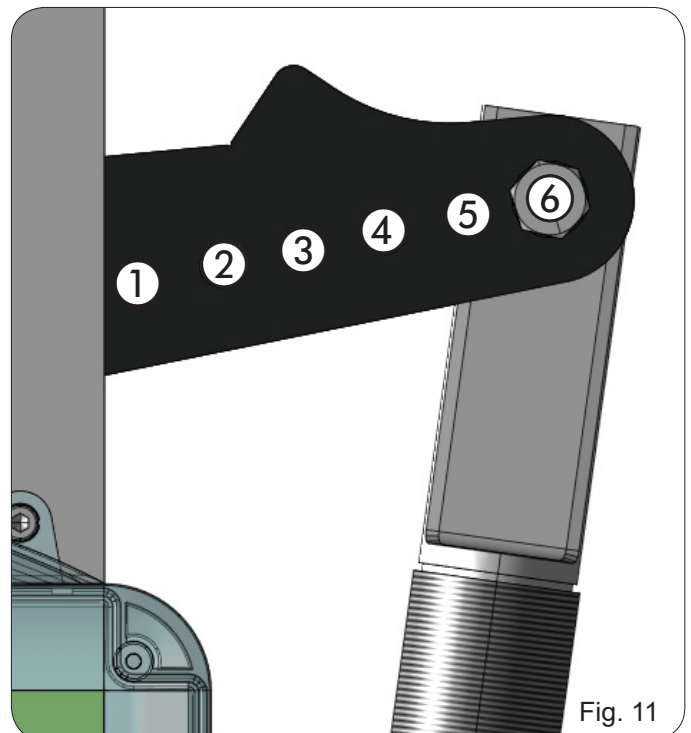

The following two tables indicate the fixing position of the pistons on the rocker arm in relation to the length of the arm and the presence of accessories secured to it, if any.

Table 1 refers to the balance spring for “S” arms (Fig. 4 ref. ①) with lengths equal to or shorter than 17.4 ft (5.3m)

Table 2 refers to the balance spring for “L” arms (Fig. 4 ref. ②) with lengths equal to or longer than 17.4 ft (5 m)

Figure 11 contains the key for identifying the fixing holes based on the number indicated in the tables.

Table 1 - S BEAMS

Beam length → Installed accessories ↓	7.5 ft (2.3 m)	9.2 ft (2.8m)	10.8 ft (3.3 m)	12.5 ft (3.8m)	14 ft (4.3m)	14.8 ft (4.5m)	17.4 ft (5.3m)
No accessories	1	2	3	4	4	6	6
Lights	1	2	3	4	4	6	6
Lights / Skirt	1	2	4	5	6	6	
Lights / Foot / Skirt	2	3	4	6	6	6	
Lights / Foot	2	3	3	5	6	6	
Foot	1	2	3	5	6	6	
Skirt	1	2	3	4	6	6	
Skirt / Foot	2	3	4	5	6	6	

Table 2 - L BEAMS

Beam length → Installed accessories ↓	17.4 ft (5.3 m)	19 ft (5.8m)	20.5 ft (6.3m)	22.3 ft (6.8m)	23.8 ft (7.3m)	25.5 ft (7.8m)	27 ft (8.3m)
No accessories	2	3	3	4	4	4	5
Lights	2	3	3	4	4	5	6
Lights / Skirt	2	3	4	4	5	6	
Lights / Foot / Skirt	3	4	4	5	6		
Lights / Foot	2	3	4	4	5	6	6
Foot	2	3	4	4	4	5	6
Skirt	2	3	4	4	5	6	
Skirt / Foot	3	3	4	4	5		

- Install the arm bracket and the arm as shown in the sequence in Fig. 12 from ① to ⑧ using the supplied screws. (the rubber profile of the arm must face down)

 **NOTE:** Do not grease the bolt holding the arm.

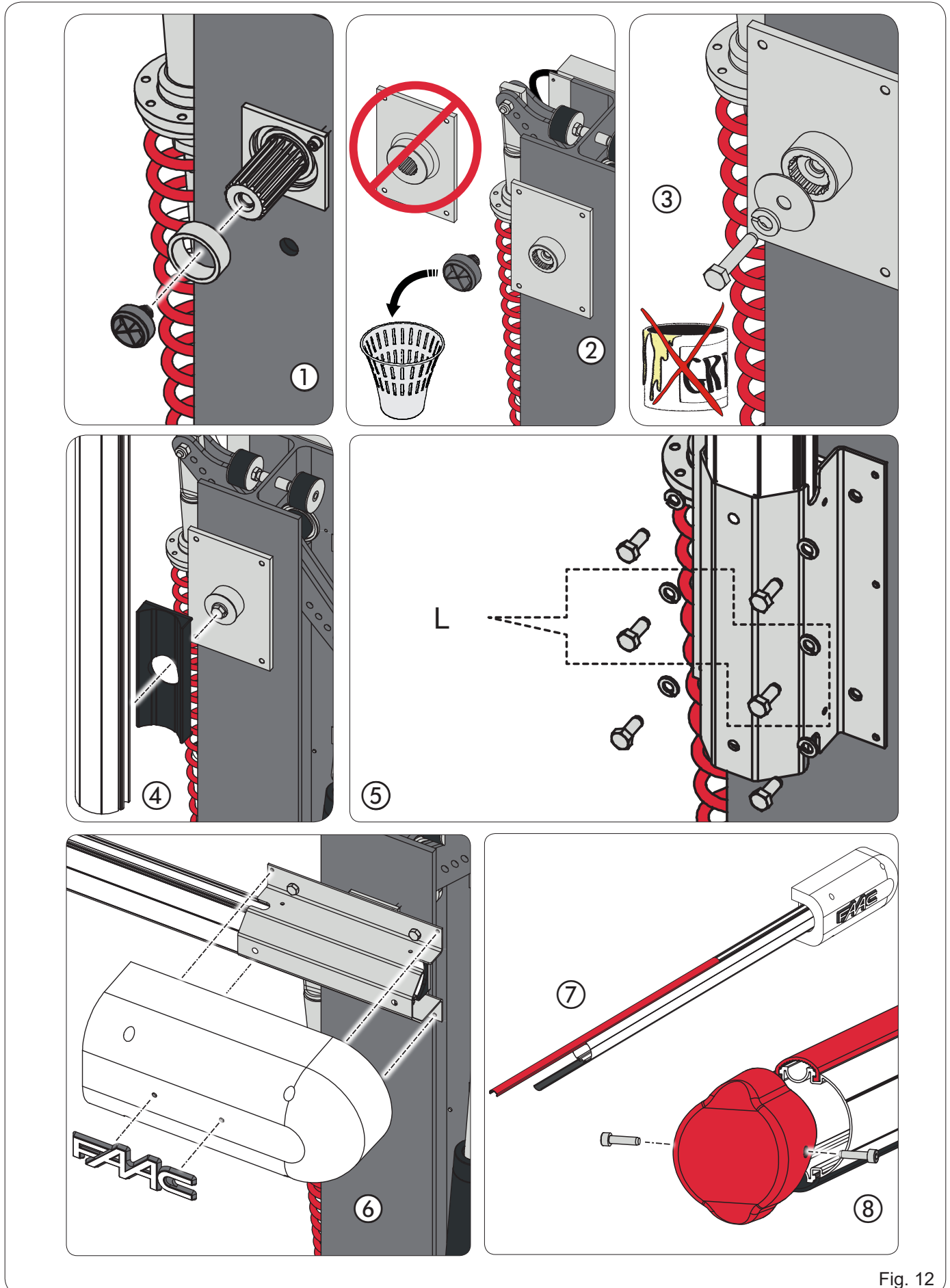
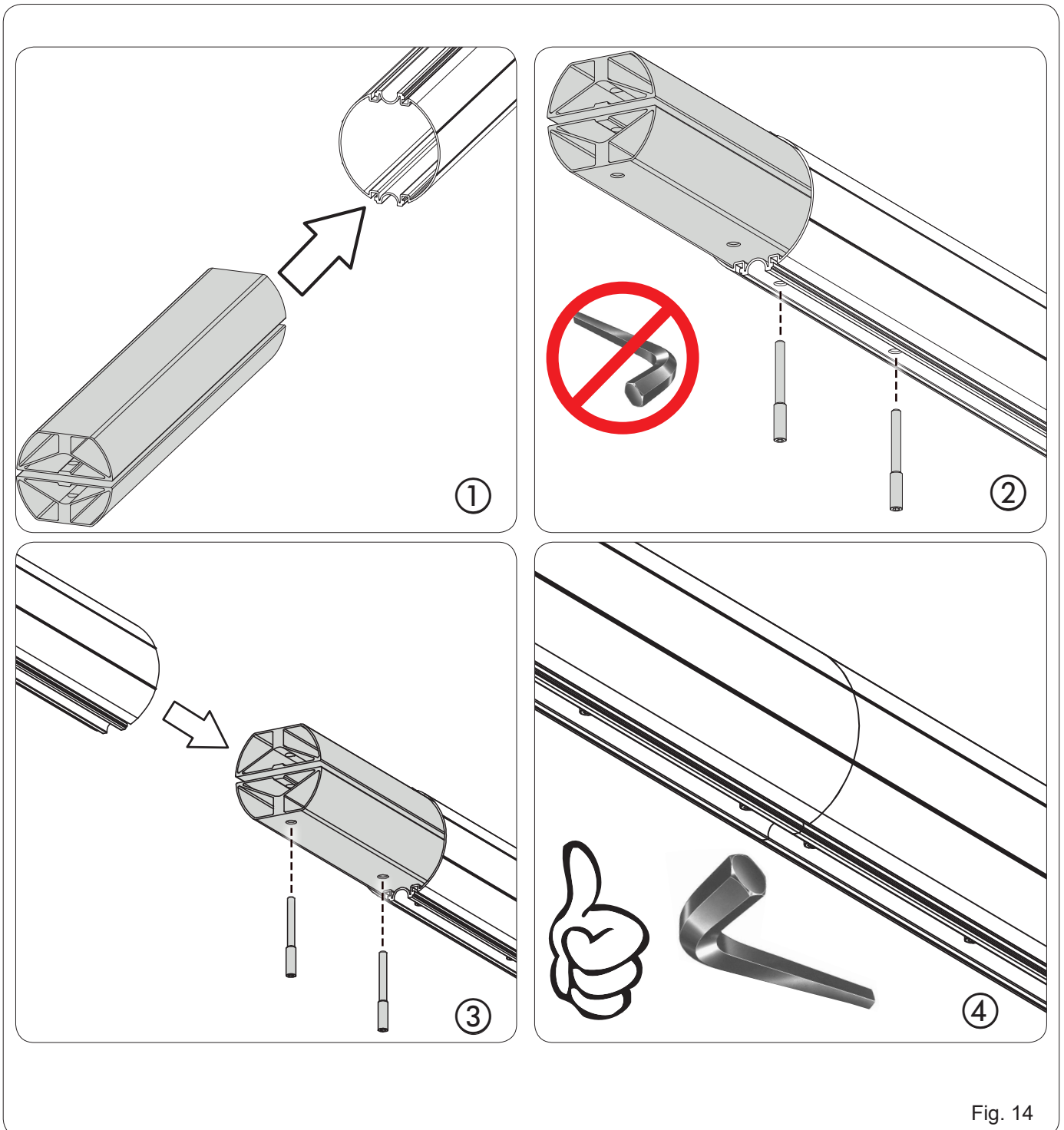
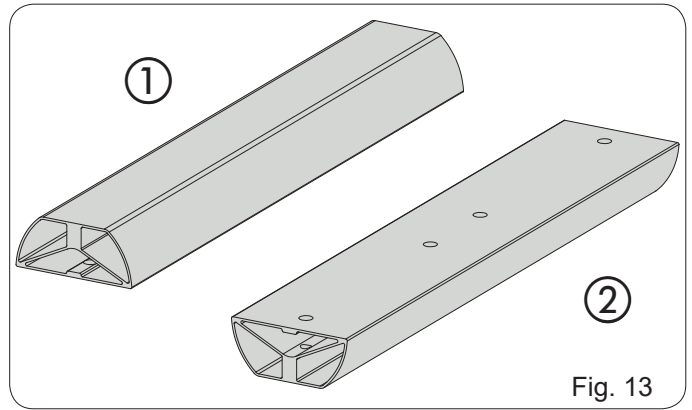

Fig. 12

- If the application requires a sectional arm, prepare the joint as shown in Fig. 13 and follow the steps shown in Fig 14 from ① to ④ to add the additional section



- Manually release the unit and take the arm to the open and close positions
- Adjust the opening and closing mechanical stops as shown in Fig. 15, and tighten the lock nut.



Fig. 15

4.4 Balancing the Arm

WARNING: This procedure is mandatory as the barrier is not balanced at the factory. The arm is balanced when, with the operator released, (ref. par. 5) the arm remains stationary in the 45° position.

To balance the arm, proceed as follows:

- Install the arm and all related accessories on the barrier structure, as required by the final configuration of the system.
- Make sure that the operator is released.
- Manually move the arm to the 45° position and verify that it remains stationary. If the arm tends to open, turn the spring preload ring nut anti-clockwise (Fig. 16 ref. ①); if it tends to close, turn the ring nut clockwise (Fig. 16 ref. ②).
- Adjustments are easily made with the arm in the open position

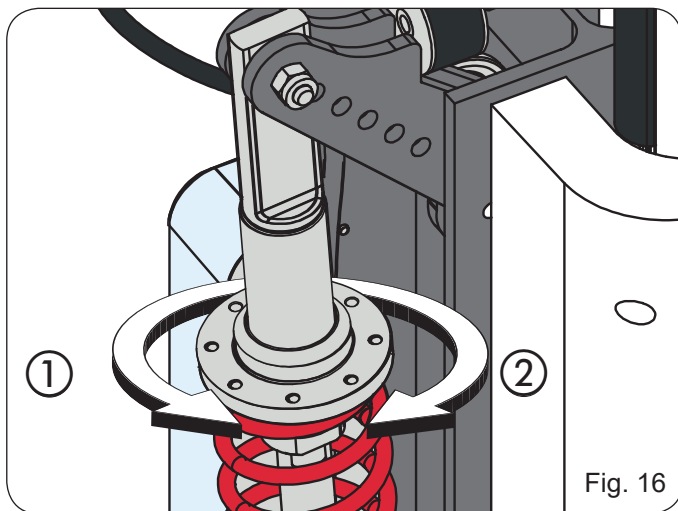



Fig. 16

5. MANUAL OPERATION

Should manual operation of the barrier be required due to power outage or malfunction, the manual release device can be operated with the supplied key. The key is either triangular (Fig. 17 ref. ①) or customised (Fig. 17 ref. ②) optional.

- Insert the key in the lock and turn it **all the way counter clockwise** until it clicks into place, as shown in Fig. 17
- Open or close the arm manually.

 **With the arm released, the motor may start for approximately 3 seconds. This is normal and determined by the parameter Hold Close / Hold Open**

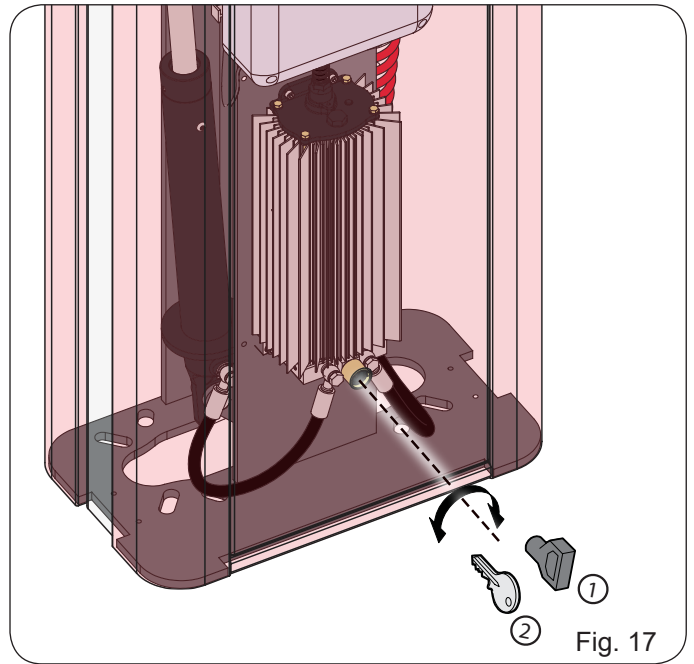

Fig. 17

5.1 RESTORING NORMAL OPERATION

To avoid an accidental opening the barrier during this operation turn the power off before using the locking system.

To restore normal operation turn the key **all the way clockwise** until it stops and then remove it

- (Fig. 17 ref. ①) standart triangular key
- (Fig. 17 ref. ②) optional metal key

6. POWER CONNECTION

AC POWER GUIDELINES:

The B680H uses a single phase AC power line to operate, charge the optional batteries, and power gate accessories. Use the following guidelines when installing the AC power:

1. Check the local wiring codes in all cases and follow all local building codes. Wiring and hookup should be performed by a qualified electrician/installer only.
2. AC power should be supplied from a circuit breaker panel and must have its own dedicated circuit breaker. This supply must include a green ground conductor.
3. Use copper conductor wires with liquid tight flexible conduit UL listed for electric cable protection
4. Properly ground the operator to minimize or prevent damage from power surges and/or lightning. Use a grounding rod if necessary. A surge suppressor is recommended for additional protection.

AC POWER CONNECTION

To connect AC power to the controller:

1. Turn OFF the circuit breaker for the AC gate operator power before connecting the AC input wires.
2. Turn OFF the Power Switch in the B680H before connecting the AC input wires.
3. Connect the AC input wires to the power switch in the B680H See the Fig. 18 for the connections.
4. Connect Ground to the dedicated terminal as shown in the Fig. 18

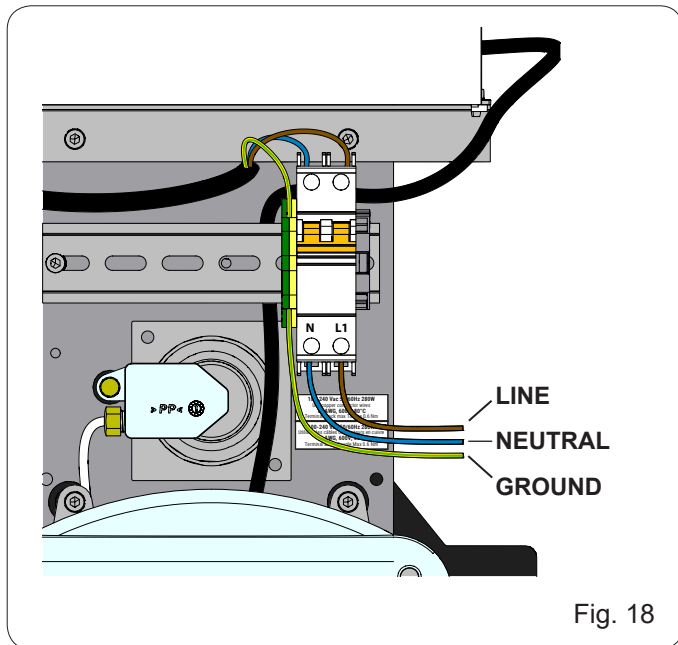
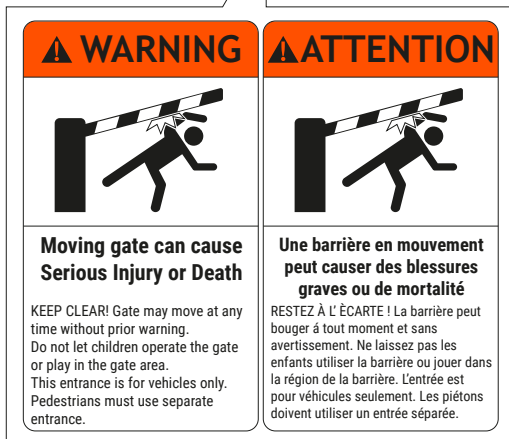
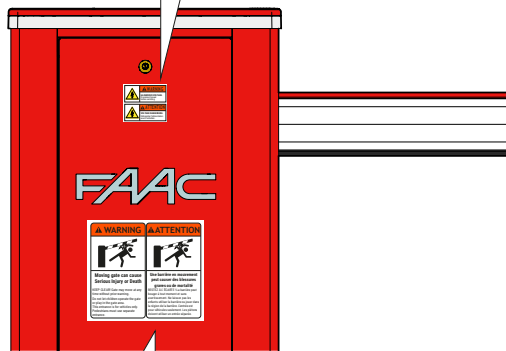
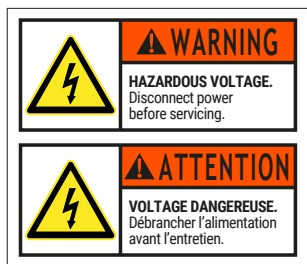

Fig. 18

7. FIELD INSTALLED LABELS

Apply the following supplied field install labels:



8. REVERSING THE OPENING DIRECTION

The opening direction of the barrier is determined by the location of the spring, the spring guide and the preload adjustment ring. The spring must be compressed during the closing movement (see Fig. 7). Should it be necessary to change the opening direction, proceed as follows:

- Release the operator, place the arm in vertical position, then lock the operator again.
- Remove the arm referencing Fig. 12
- Loosen the pre-load nut ring if there is any pressure on it, so there is no spring tension against the pre-load nut before you remove the piston.
- Remove the bolt securing the plunging piston to the rocker arm, as shown in Fig. 9.
- Remove the pre-load ring nut, then remove the balancing spring and spring guide, reversing the order described in Fig. 10.
- Reattach the piston in the correct hole on the rocker arm
- Release the operator, turn the rocker arm 90°
- Remove the bolt holding the piston on the opposite side and re-insert, in order, the spring guide, the balancing spring and the ring nut in the piston installed on the new closing side, according to the order described in Fig. 10. Once this is done, reattach the piston on the rocker arm.
- Reinstall the arm following the instructions in Fig. 12.
- Balance the system once again following the procedure described in par. 4.4.
- Relock the operator following the instructions in par. 5
- Reverse the motor cable connection as shown below

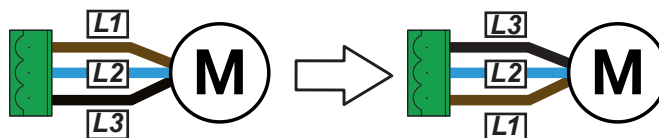

9. MAINTENANCE

When performing periodic maintenance, always check for correct balancing of the system and correct operation of the safety devices.

9.1 Topping up the oil

Check the amount of oil in the tank every 6 months. The level must be between the two notches on the inspection stick. To top up, unscrew the filler cap (Fig. 8 ref. ①) and pour oil up to the indicated level. Use only FAAC HP OIL.

9.2 Air bleeding

FAAC products are delivered already bled of any air in the hydraulic circuit. Maintenance operations, replacing spare parts (e.g. hydraulic hoses) or careless transport can cause entry of air in the hydraulic circuit, which in turn can cause irregular movement of the operator or reduced torque. Should the arm movement be irregular, release the air from the hydraulic system following the instructions below:

- Electrically operate the arm:
- When opening is completed, slightly loosen and tighten the bleeder screw of the piston with the balance spring (Fig. 1 ref. ④).
- When closing is completed, slightly loosen and tighten the bleeder screw of the piston without the balance spring (Fig. 1 ref. ②).

If necessary, repeat the operation until regular movement of the arm is obtained.

 **Care needs to be taken at this stage as the pistons contain oil under pressure which could leak out if the screws are loosened too much.**

 **If the parameters FO and FC in Advanced Configuration have been changed and set to a value lower than default, we recommend setting them to an equal or greater value during bleeding, to facilitate the operation.**

10. INSTALL THE ARM LIGHTS

Installation of the LED light kit increases the visibility of the arm. The LED rope lights will sit in the top groove of the arm, and will be connected to the control board using the supplied connector and cord. Follow the instructions in Fig. 19.

- Plug the connector to the end of the rope light, making sure the pins make good connections with the wires
- Measure and cut the rope light. It should be cut longer than the arm and the excess gets wrapped into the end of it as shown in ③. Take care to not force it which will damage the LED's. **CUT ONLY WHERE THE MARKS ARE**
- Put the black cap on the end of the rope light

- Route the cable following to the path shown using zip ties. Make sure to go over the I-Beam as shown in ⑤
- Connect the two wires to the the top and middle terminals of J16 on the electronic board.
- Configure the board according to the available modes (refer to Par 4.12 in the control board section)

NOTE: Make sure the two connectors make good contact with the wires inside the rope light. Should the lights still not turn on, reverse the connection polarity. You can also use a 24V battery for this test

IMPORTANT: Once verified that the the lights turn on properly apply heat to the heat shrink tubing at the end of the connector to seal it to the rope light.

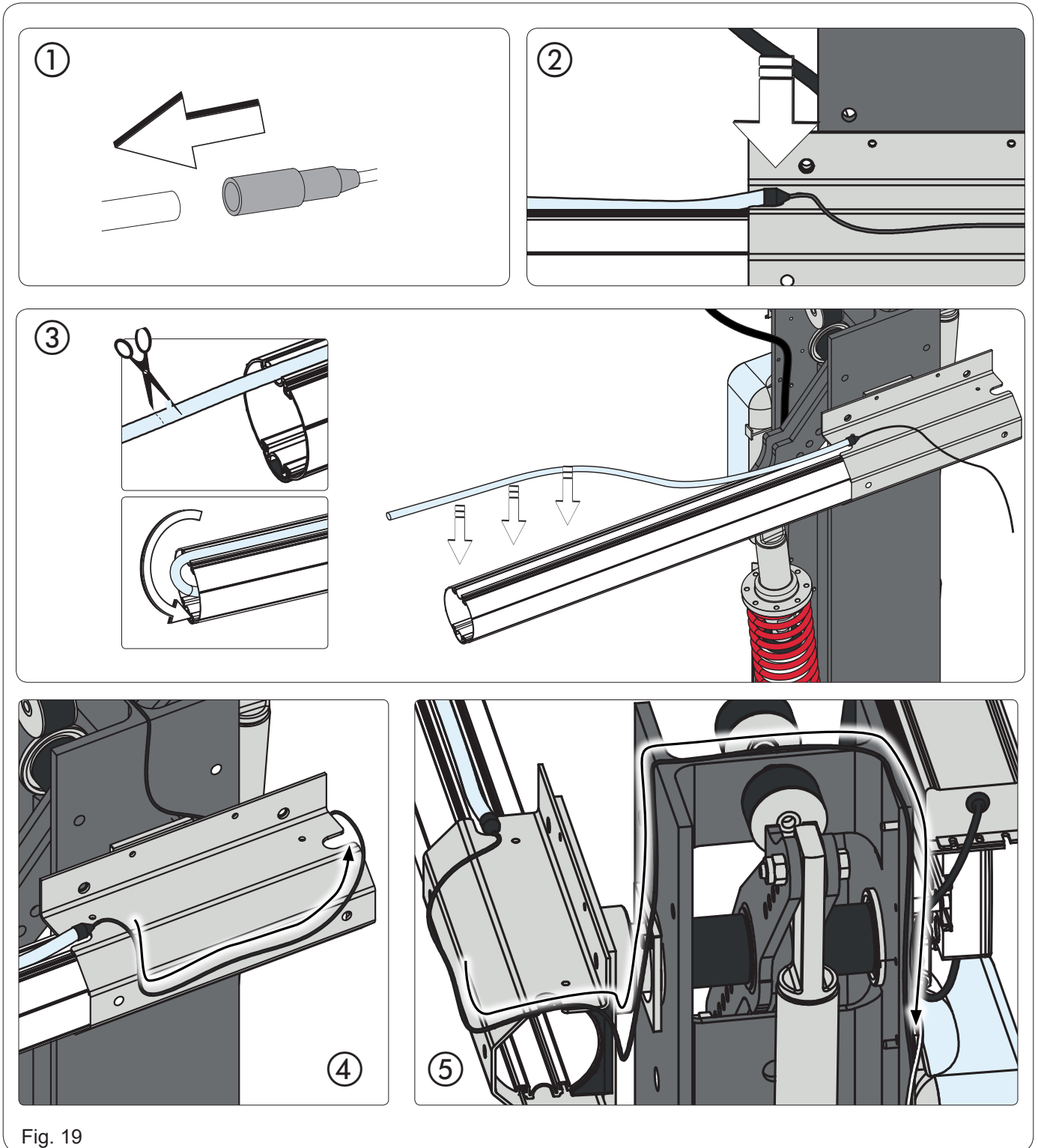

Fig. 19

11. INSTALL THE COVER

To install the protective cover on the operator follow the steps shown in Fig. 20.

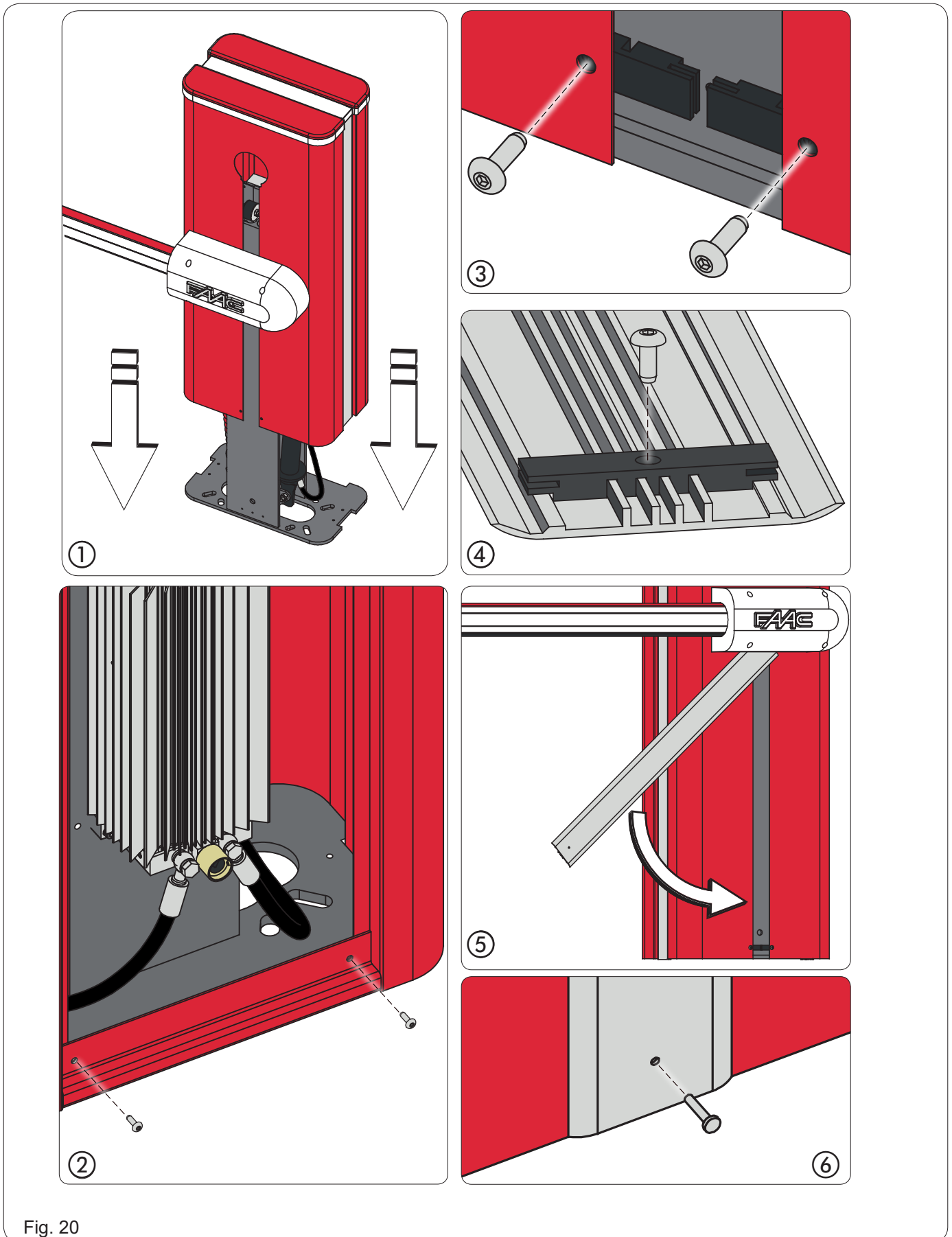
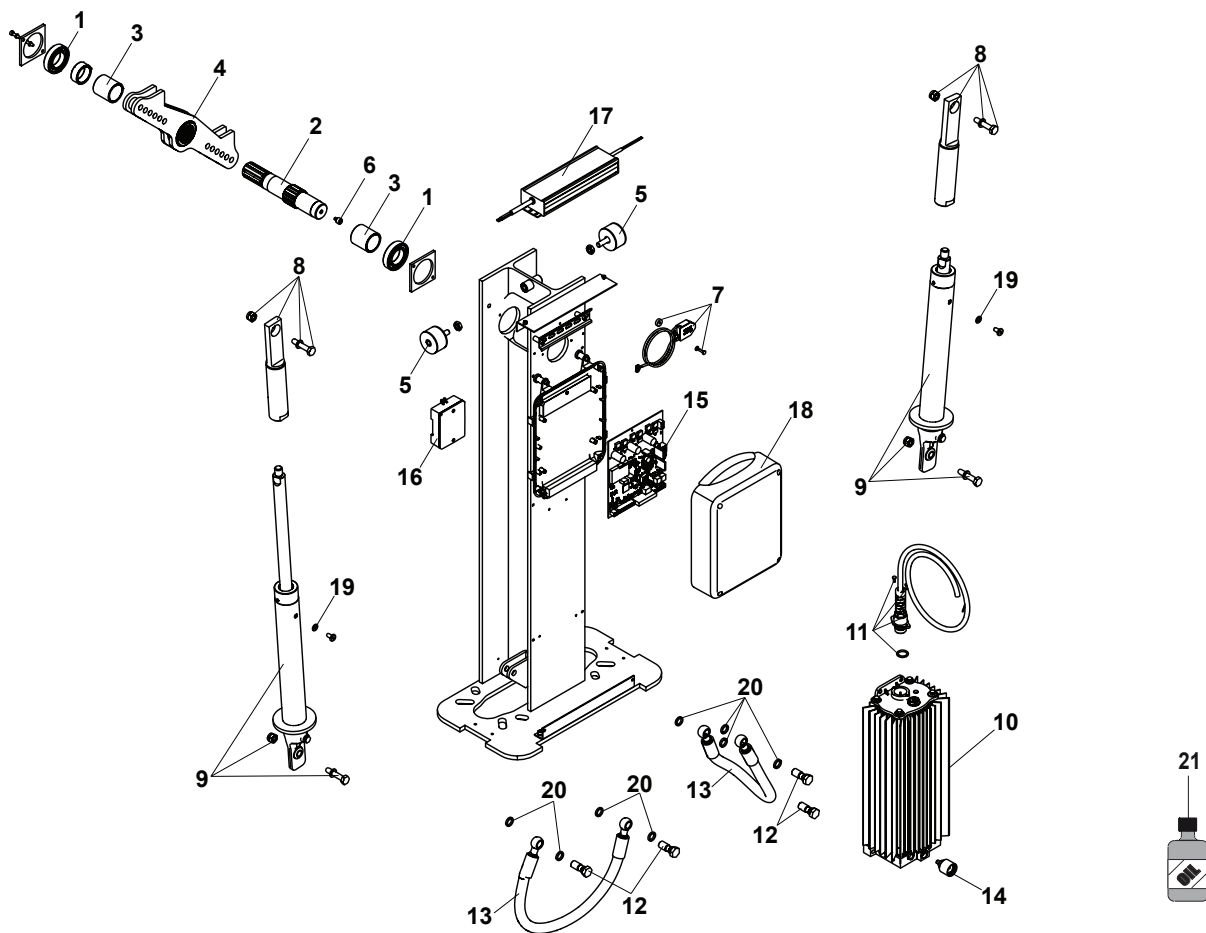
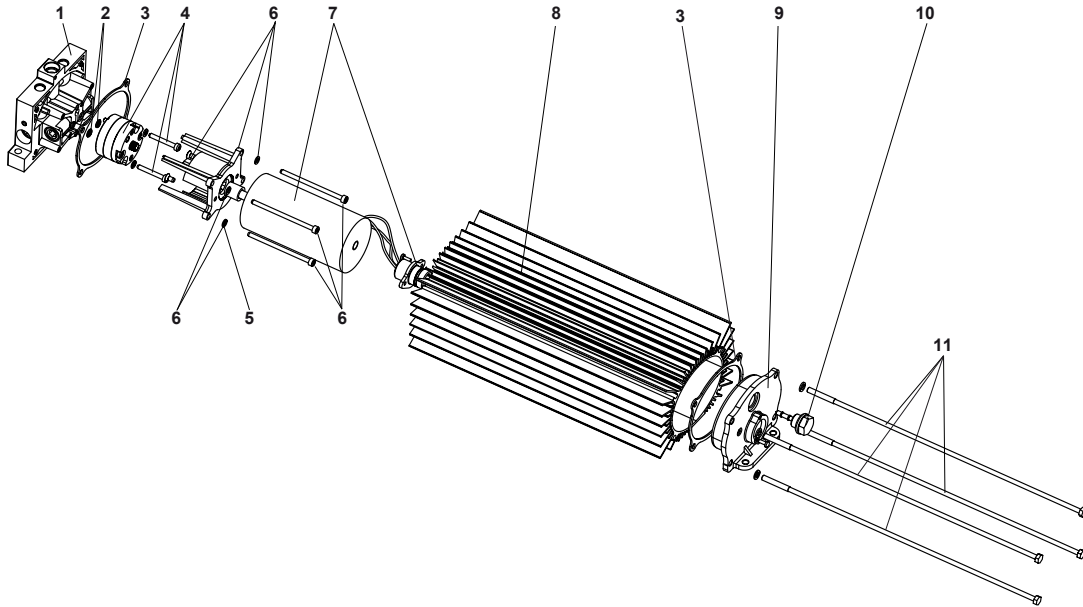

Fig. 20

12. SPARE PARTS



Part	Part Number	Description
01	63000108	Bearing
02	63000118	Splined Shaft Kit
03	63000137	Lever Bearing Spacer
04	63000132	Rocker Arm
05	63000131	Positive Stops
06	63000138	Encoder Magnetic Sensor
07	63000111	Encoder
08	63000109	Fork With Ball Joint Group
09	63000133	Cylinder
10	63000129	Hydraulic Unit
11	63000113	Female Connector Kit
12	7110115	Eye Bolt
13	63000112	Hydraulic Hoses
14	63000117	Manual Release Group
15	63000128	Electronic Control Board
16	-	Power Switch
17	63000119	B680 Power Supply Group
18	63000139	E680 Control Board Box Cover



Part	Part Number	Description
01	63000162	Distribution Flange Group
02	7090010015	O-ring 4.48 X 1.78
03	63000154	Hydraulic Unit Gasket
04	63000696	1,5 L/Min Pump
05	703101	Lock Washer
06	63000123	Motor/Pump Interface Flange
07	63000122	Brushless Motor Group
08	63000159	Hydraulic Tank
09	63000124	Tank Cover
10	7112065	Oil Level Plug With Level Indicator
11	63000158	Hydraulic Unit Tie Rod

E680 CONTROL BOARD

1. WARNINGS

- Before attempting to connect any wiring to the control board make sure that the power switch is in the OFF position
- It is good practice to separate the power cables from the control and safety cables (activation, receiver, photocells, etc.). This can also be a mandatory requirement in the local building code
- It is recommended that a licensed electrical contractor performs all the wiring work.

2. DESCRIPTION OF THE COMPONENTS

Fig. 21

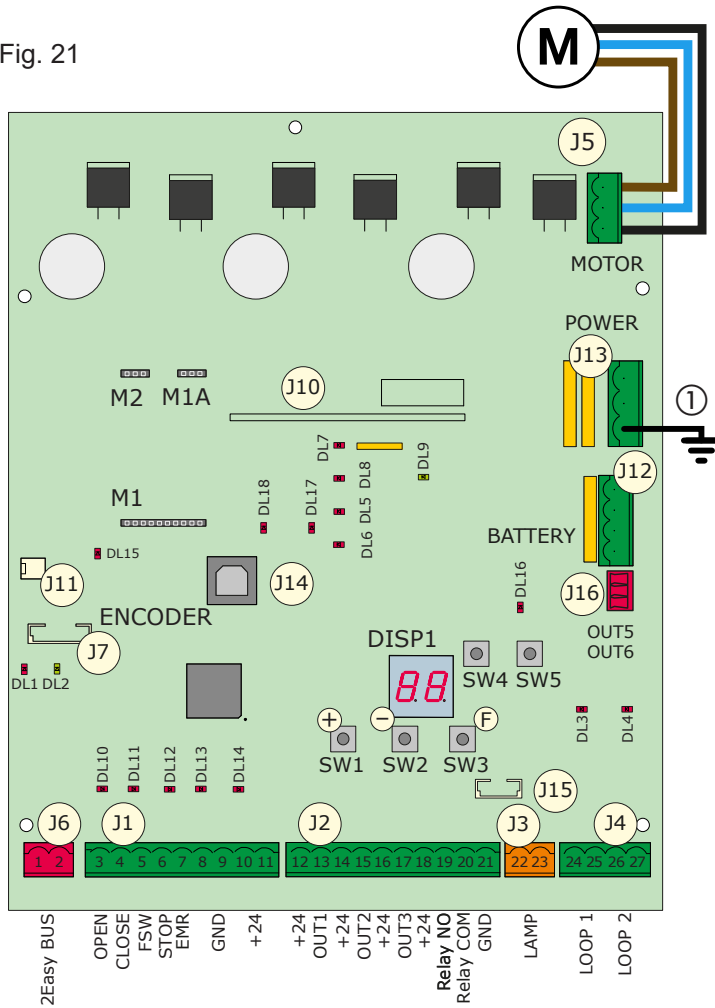

3. TECHNICAL SPECIFICATIONS

DISP1	Signalling/Programming display
DL1	BUS Device status
DL2	BUS status (see paragraph 5.3)
DL3	LOOP 1 status
DL4	LOOP 2 status
DL5	Board failure signal
DL6	Not used
DL7	Encoder status
DL8	Not used
DL9	Board power supply present
DL10	OPEN input status LED
DL11	CLOSE input status LED
DL12	FSW input status LED
DL13	STOP input status LED
DL14	EMR input status LED
DL15	Released bar signal
DL16	Battery power signal
DL17	Radio channel 1 activity
DL18	Radio channel 2 activity
J1	Input signal connector
J2	Digital output connector
J3	Signalling lamp connector
J4	Detection loop connector
J5	Motor connector
J6	BUS 2Easy connector
J7	Arm movement encoder connector
J10	Connector for radio board
J11	Released bar detection connector
J12	Emergency battery connector
J13	Continuous power voltage connector
J14	USB connector for firmware upgrade
J15	Integrated flashing traffic light connector
J16	Arm Lights Connector
SW1	Programming key "F"
SW2	Programming key "+"
SW3	Programming key "-"
SW4 /SW5	LOOP 1 / LOOP 2 calibration button
M1/M1A/M2	Optional module connector (Connectivity):

4. ELECTRICAL CONNECTIONS

Mains power voltage	100-240 V~ +6% -10% connected to switching power supply
Continuous power voltage	36 V ==
Absorbed power	240W
Accessories power supply	24 V ==
Max accessories current	800 mA
Operating ambient temperature	-4 °F +131 °F (-20 °C +55 °C)
Protection fuses	4 self-restoring
Pause time	Programmable (from 0 seconds to 4.1 minutes)

Work time	Programmable (from 0 to 4 minutes)
Motor power	Programmable on 50 levels
Motor speed	Programmable on 10 levels
Programmability	3 configuration levels for greater flexibility of use
Rapid connector	1 5-pin connector for radio board
Programmable outputs	4 programmable outputs in 19 different functions
Specifications	Deceleration management, encoder, multi-function display, BUS technology and built-in loop detectors

4.1 Terminal board J1 (inputs)

Fig. 22

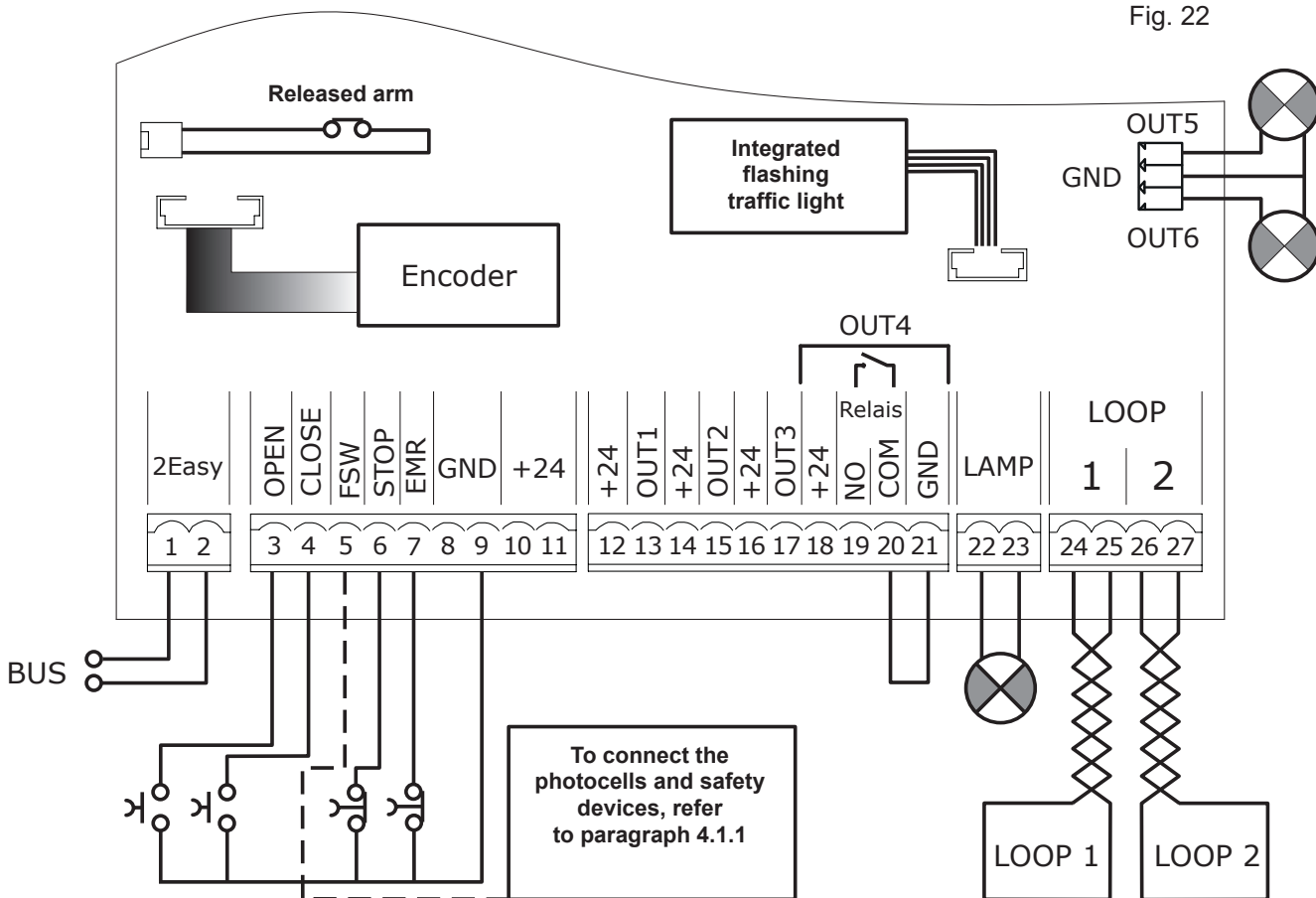

OPEN - Open command (N.O. - terminal 3): means any pulse generator (e.g. button) which, by closing a contact, commands opening and/or closing of the barrier.

CLOSE - Close command (N.O. - terminal 4): means any pulse generator (e.g. button) which, by closing a contact, commands closing of the barrier.

FSW - Safety contact when closing (N.C. - terminal 5): the purpose of the closing safeties is to protect the area affected by the movement of the barrier during the closing phase, reversing its motion. *They don't affect the opening cycle.*

The closing Safeties, if engaged when the automated system is open, prevent the closing movement.

! *If CLOSE safety devices are not connected, jumper terminals FSW and GND (Fig. 26) and leave the FAILSAFE function (parameter \square in Advanced Configuration) set on the default value (disabled)*

STP - Stop contact (N.C. - terminal 6): means any device (e.g. button) which, by opening a contact, can stop movement of the automated system.

! *If STOP safety devices are not connected, jumper terminals STOP and GND (Fig. 26)*

EMR - Emergency contact (N.C. - terminal 7): means any device (e.g. switch) which, if activated in an emergency situation will open the barrier until the contact is restored. When activated, this input has priority over any other command.

! *If emergency safety devices are not connected, jumper terminals EMR and GND (Fig. 26)*

GND (terminals 8-9) - Accessories power supply minus
+24 (terminals 10-11) - Accessories power supply plus

! **The maximum load of the accessories is 800mA. To calculate absorption, refer to the instructions included with the individual accessories.**

4.1.1 Connecting the safety devices

The E680 control board features an input for closing safety devices, which are active during closing of the automated system. It's used to protect the gate area from the risk of impact with the arm.

These devices must use a signal with "N.C." contact, and must be connected in series to the relay photocells that may be installed on the system, as shown in Fig. 23 to Fig. 26.

Fig. 23: connection of one pair of closing photocells, with FAILSAFE safety enabled: in addition to making the connection as shown in the diagram, it is necessary to set in Advanced Configuration $\square = \square$

Fig. 24: connection of one pair of closing photocells without FAILSAFE safety

Fig.25: connection of two pairs of closing photocells without FAILSAFE safety

Fig. 26: connection of no safety device

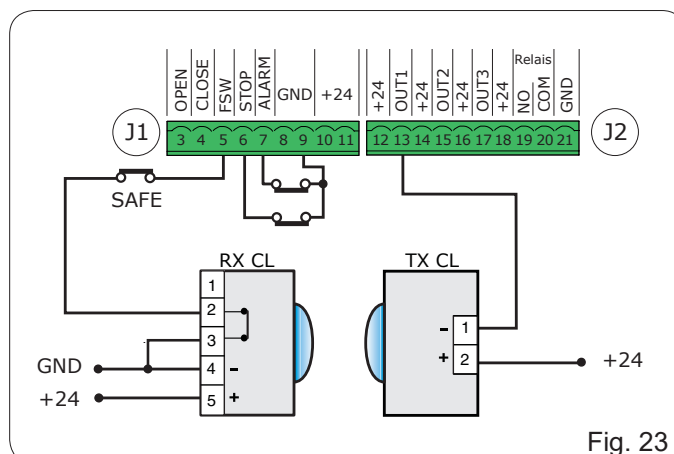

Fig. 23

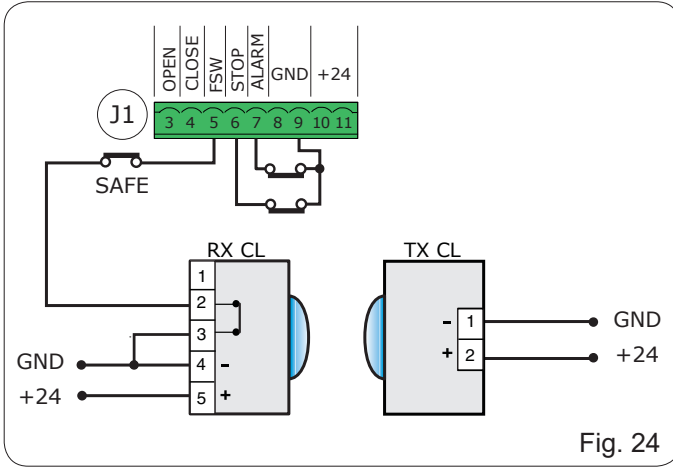

Fig. 24

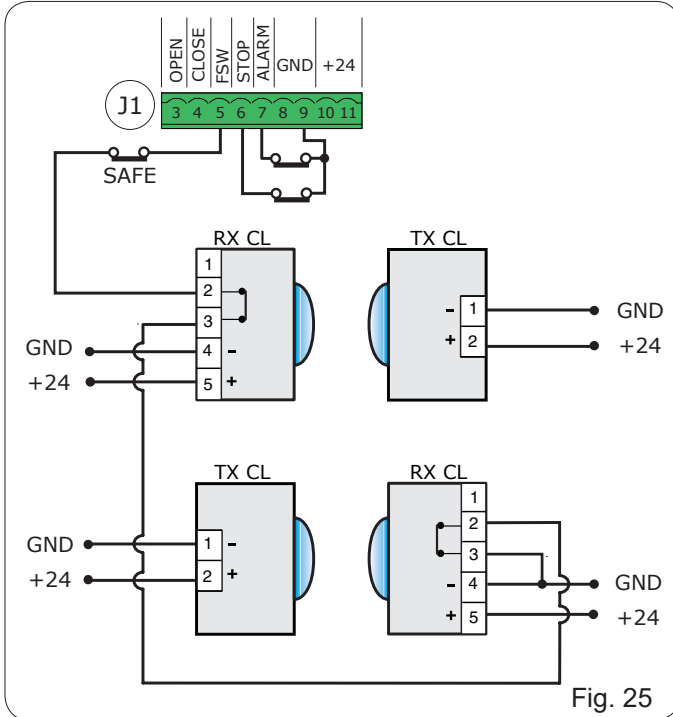

Fig. 25

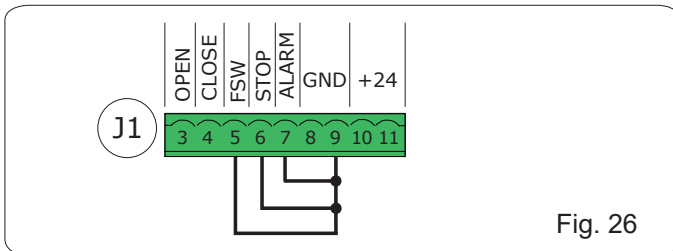

Fig. 26

4.2 Terminal board J2 (outputs)

OUT 1 - Output 1 open-collector GND (terminal 13): The output can be set in one of the functions described in the Advanced Configuration (par. 6). The default value is 04 - Arm OPEN or in PAUSE. **Maximum load: 24 VDC with 100 mA.**

OUT 2 - Output 2 open-collector GND (terminal 15): The output can be set in one of the functions described in the Advanced Configuration (par. 6). The default value is 03 - CLOSED Arm. **Maximum load: 24 VDC with 100 mA.**

OUT 3 - Output 3 open-collector GND (terminal 17): The output can be set in one of the functions described in the Advanced Configuration (par. 6). The default value is 19 - WARNING LAMP. **Maximum load: 24 VDC with 100 mA.**

OUT 4 - Relay output 4 (terminals 19, 20, 21): The output can be set in one of the functions described in Advanced Configuration (par. 6). The default value is 01 - Arm ILLUMINATION. **Maximum load: 24 VDC with 800 mA.**

4.3 Terminal board J3 (external flashing lamp)

LAMP: to these terminals you can connect a 24VDC FAACLED external flashing lamp. *The integrated flashing traffic light must be connected independently to connector J15.*

The 24V FAACLIGHT with incandescent lamp cannot be connected to the J3 connector

4.4 Terminal board J4 (loop detector)

LOOP 1: magnetic loop LOOP 1 (OPEN, terminals 24-25): for **OPENING**.

LOOP 2: magnetic loop LOOP 2 (SAFETY/CLOSE, terminals 26-27): for **SAFETY/CLOSING**.

4.5 Connector J5 (Motor)

Rapid connector for connecting the motor.

4.6 Connector J7 (Encoder)

The B680H barrier is equipped with a device for detecting the position and speed of the arm to ensure greater anti-crushing safety thanks to the possibility of reversing the direction of movement the moment an obstacle is detected. This device is connected to the board with J7.

4.7 Connector J10 (Radio)

Used for the rapid connection of the RP / RP2 Receivers. If a 2-channel receiver is used, like the RP2, it will be possible to directly command OPEN and CLOSE movements from a 2-channel radio control. If a 1-channel receiver is used, like the RP, it will only be possible to command OPEN.

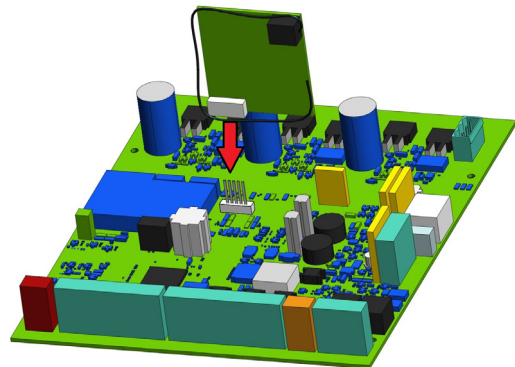

The radio board should be inserted and removed ONLY with power OFF

4.8 Connector J11 (Arm break-out sensor)

Designed for connecting the break-out sensor for the pivoting arm (if present). The sensor is optional. If it is not present, *do not remove* the installed jumper.

4.9 Connector J12 (Battery backup)

This is where the optional battery backup is connected. The battery will ensure the B680H operation in case of temporary loss of the main power supply.

4.10 Connector J13 (36VDC Power Supply)

This factory-wired connector powers the E680 board.

The terminal shown in Fig. 21 ref. ① must be connected to the earth ground to minimize electrical noise

4.11 Connector J15 (flashing traffic light)

This is where the flashing traffic light built into the barrier cover is connected. The flashing traffic light visually signals barrier movement and, if needed, can control access to the property using the different light colors.

4.12 Connector J16 (arm lights)

This is where the rope light for the arm is connected, providing visual warning of barrier movement. The connector has a common GND in the middle and two +36V (BLR / BLG) outputs. BLR is OUT5 on the board's configuration and BLG is OUT 6. **The rope light gets connected to BLR and GND.**

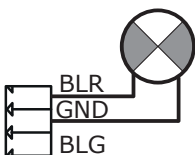

To change the behaviour of the arm lights set the mode of OUT5 in Advanced Configuration

5. PROGRAMMING

The E680 board features 3 programming levels that make it entirely configurable and allow it to adapt the logics to any use. Each of the three levels can be accessed through a specific key combination.

Changes to the configuration parameters become effective immediately, while final storage occurs only upon exiting configuration and returning to the automated system status display. If the equipment is powered down before returning to the automated system status display, all changes made will be lost.

5.1 Basic configuration

To perform BASIC programming:

1. Press and hold button **F**; the name of the first function is displayed.
2. Release the button; the function value is displayed and can be modified using the + and - buttons.
3. Press and hold **F** again; the name of the following function is displayed, and so on.

The last function **SE** lets you choose whether to save the configuration made (**Y**) or exit without saving (**NO**). Later, the display will resume showing the automated system status

You can go to **SE at any time. To exit programming, press **F** and then -.**

BASIC CONFIGURATION		
Display	Function	Default
cF	Barrier configuration 01 Minimum mass 06 Maximum mass Before starting the operator, you must set the correct value, directly correlated to the length of the arm and the number and type of accessories installed. To determine the value, refer to Tables 3 and 4. WARNING: Setting a mass default lower than the one actually installed could cause irreversible damage to the bar and barrier structure. Loading a different configuration will reset the parameters to the default values	06
dF	Default Y indicates that all values set correspond to the defaults NO indicates that one or more set values are different from the defaults. Select Y to restore the default configuration.	Y

Display	Function	Default
CE	Master / slave configuration MA Configures the board in master mode SL Configures the board in slave mode For details on MASTER / SLAVE configuration, refer to section 9.	MA
bu	BUS accessories menu For functions associated with this parameter see paragraph 5.3	no
LO	Operating logics A Automatic AI Automatic 1 E Semi-automatic P Parking PA Parking automatic Cn Condo CA Condo automatic C Dead-man CU Custom	E
PA	Pause time Is effective only if an automatic logic is chosen; the value can be set from 0 to 59 sec. in one second steps. Next, the display changes to minutes and tens of a second (separated by a decimal point) and time is adjusted in 10-second steps up to the maximum value of 4.1 minutes. e.g. if the display shows 2.5, the pause time will be 2 minutes and 50 seconds.	20
SO	Opening speed Adjusts the barrier opening speed. 00 Minimum speed 10 Maximum speed <i>NOTE: The actual maximum speed is dependent on the "mass" value programmed in Barrier Configuration</i>	10
Sc	Closing speed Adjusts the barrier closing speed. 00 Minimum speed 10 Maximum speed <i>NOTE: The actual maximum speed is dependent on the "mass" value programmed in Barrier Configuration</i>	02
LI	Loop 1 Activating this parameter, any loop that is connected to the Loop 1 input will serve as an OPEN function. Y Loop 1 enabled NO Loop 1 disabled <i>NOTE: Should this function be disabled, the detection status of the loop will in any case remain available on one of the two outputs, if configured (see parameters 01... 04 in Advanced Configuration)</i>	no

Display	Function	Default
L2	<p>Loop 2 Activating this parameter, any loop that is connected to the Loop 2 input will serve as a SAFETY/CLOSE function.</p> <p>Y Loop 2 enabled no Loop 2 disabled</p> <p>(see note regarding Loop 1)</p>	no
S1	<p>Loop 1 sensitivity Adjusts the sensitivity of the vehicle detection loop</p> <p>00 Minimum sensitivity 10 Maximum sensitivity</p>	05
S2	<p>Loop 2 sensitivity Adjusts the sensitivity of the vehicle detection loop</p> <p>00 Minimum sensitivity 10 Maximum sensitivity</p>	05
Mt	<p>Motor movement Using the function provided by this parameter makes it possible to manually move the barrier bar, operating as <i>dead-man</i>. Pressing + will open the automated system, pressing - causes the automated system to close.</p> <p>oP pressing +, open cL pressing -, close</p>	--
Et	<p>Learning Working time and limit switch learning (see section 7.2)</p>	--
St	<p>SYSTEM STATUS: This allows you to choose whether to save the programmed data upon quitting. Y = quit and save the data no = quit without saving the data After quitting the program, press the F key to display the status of the automated system</p> <p>00 Beam closed 01 Beam open 02 Stationary ready to open 03 Stationary ready to close 04 Automated system paused 05 Opening 06 Closing 07 Failsafe in progress 08 2-EASY device verification in progress 09 Pre-flashing then OPENS 10 Pre-flashing then CLOSES 11 EMERGENCY Open</p> <p>You can go to St at any time by pressing F and then -.</p>	

The system status information St is very useful during the the installation process to make sure that the control board logic and the actual barrier movement are consistent.

If, for example, the barrier's status is CLOSED, the display MUST read 00. When the OPEN command is received, the display will change to 09, if pre-flashing is enabled, or directly to 05 (the OPENING movement) to then display 01 once the position of barrier OPEN is reached).

Example of a status sequence displayed starting from a closed barrier **The sequence does not include statuses 09 and 10 which correspond to pre-flashing when opening and closing, respectively.**

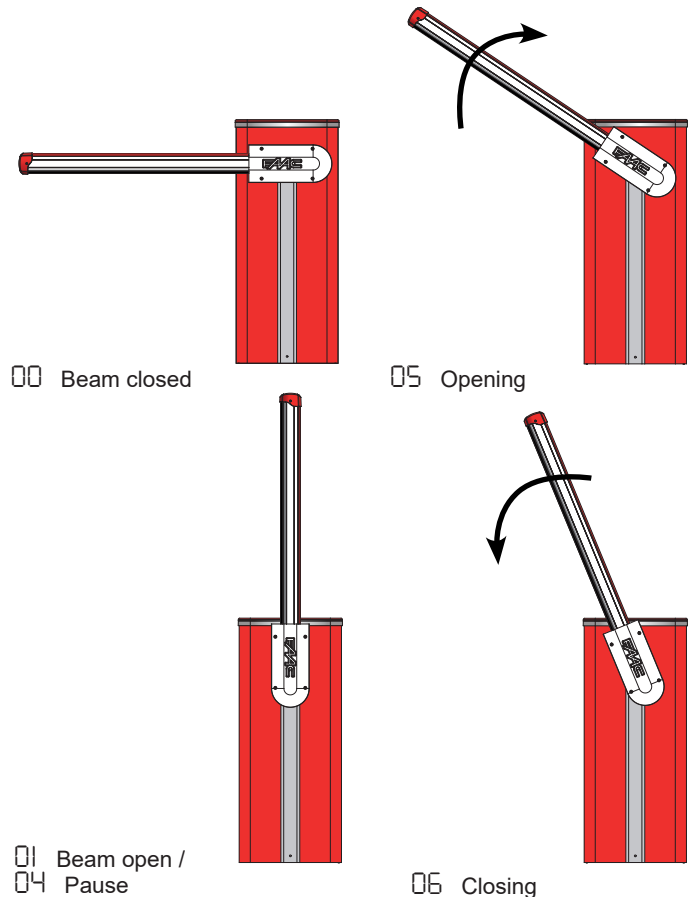

5.2 Changing the predefined parameters set

The E680 board features six sets of pre-defined configurations that allow rapid adapting to the size of the arm installed. To select one of the available configurations change the parameter cF from the default value of 06 to that corresponding to the barrier configuration (arm length, type and quantity of accessories installed) given in Table 3 or Table 4 on the next page (for example, choose the default 04 for a arm type "L" of 17.4 ft (5.3 m) with lights).

To complete the configuration, it is necessary to exit the Basic Configuration menu by pressing "F" until parameter St is reached or by pressing "F" and "-"



This operation changes the value of the parameters S0 and SC in Basic configuration and FO, FC, oC in Advanced configuration, setting them on the default values as shown in the tables in paragraph 6.3.



Setting a set of pre-defined parameters that does not correspond to the actual configuration of the barrier could cause irreversible damage to the automated system, in particular if the default corresponds to a arm length shorter than the actual one.

5.3. DEFAULT SELECTION TABLES (cF parameter)

The purpose of the two following tables is to determine, depending on the length of the bar and the number and type of accessories installed, the correct default value to set in the first Basic programming function.

Table 3 refers to the balance spring for “S” arms (Fig. 4 ref. ①) with lengths equal to or shorter than 17.4 ft (5.3m)

Table 4 refers to the balance spring for “L” arms (Fig. 4 ref. ②) with lengths equal to or longer than 17.4 ft (5. m)

Table 3 - S BEAMS

Beam length → Installed accessories ↓	7.5 ft (2.3 m)	9.2 ft (2.8m)	10.8 ft (3.3 m)	12.5 ft (3.8m)	14 ft (4.3m)	14.8 ft (4.5m)	17.4 ft (5.3m)
No accessories	1	1	2	2	2	3	3
Lights	1	1	2	2	2	3	3
Lights / Skirt	1	1	2	3	3	3	
Lights / Foot / Skirt	1	2	2	3	3	3	
Lights / Foot	1	2	2	3	3	3	
Foot	1	1	2	3	3	3	
Skirt	1	1	2	2	3	3	
Skirt/Foot	1	2	2	3	3	3	



Table 4 - L BEAMS

Beam length → Installed accessories ↓	17.4 ft (5.3 m)	19 ft (5.8m)	20.5 ft (6.3m)	22.3 ft (6.8m)	23.8 ft (7.3m)	25.5 ft (7.8m)	27 ft (8.3m)
No accessories	4	5	5	5	5	5	6
Lights	4	5	5	5	5	6	6
Lights / Skirt	4	5	6	6	6	6	
Lights / Foot / Skirt	5	5	5	6	6		
Lights / Foot	4	5	5	5	6	6	6
Foot	4	5	5	5	5	6	6
Skirt	4	5	5	5	6	6	
Skirt/Foot	5	5	5	5	6		

6. Advanced Configuration

To access Advanced Configuration, press **F** and, while holding it, also press **+**:

- when **+** is released, the number of the first available function will appear
- when **F** is also released, the value is displayed, and can be changed using **+** and **-**
- pressing **F** again, and holding it, the name of the next parameter will be displayed; when released, the value can be changed using **+** and **-**
- once the last function has been reached, pressing **F** makes it possible to either save the previously changed parameters or exit without saving the changes; the display will go back to showing the status of the inputs.

ADVANCED CONFIGURATION  + 		
Display	Function	Default
F0	Opening motor force Adjusts the thrust of the motor during the opening phase. 00 Minimum power 50 Maximum power	40
F1	Closing motor force Adjusts the thrust of the motor during the closing phase. 00 Minimum power 50 Maximum power	40
PF	Pre-flashing This parameter is used to activate the flashing lamp for 5 seconds before the selected movement. n0 disabled 00 before each movement 01 before each closing movement 02 before each opening movement 03 only at the end of the pause	n0
TP	Pre-flashing time Pre-flashing time expressed in seconds. 00 minimum pre-flashing 10 maximum pre-flashing	00

Display	Function	Default
00	Sensitivity of obstacle during closing This determines the sensitivity to an obstacle before reversing takes place. 01 Minimum sensitivity 50 Maximum sensitivity	30
01	Output 1 Setting this function makes it possible to modify the signal type of output 1, allowing high connection flexibility with external devices. 00 Failsafe 01 TYPE 1 ARM LIGHTS MODE: output active when arm closed, disabled with arm open or paused, intermittent when moving. (Use with OUT5) 02 TYPE 2 ARM LIGHTS MODE: flashing output during opening, closing and with rod closed or stopped. inactive with rod open or paused. (Use with OUT5) 03 Arm CLOSED 04 Arm OPEN or in PAUSE, it goes off during closing pre-flashing. 05 Arm in OPENING MOVEMENT, including pre-flashing. 06 Arm in CLOSING MOVEMENT, including pre-flashing. 07 Arm STATIONARY 08 Arm in EMERGENCY mode 09 LOOP1 engaged 10 LOOP2 engaged 11 OPEN for E680 slave 12 CLOSE for E680 slave 13 Beam RELEASED 14 Not used 15 Not used 16 FCA engaged 17 FCC engaged 18 Interlock 19 WARNING LAMP: on during opening and pause, flashing when closing, off when the automated system is closed 20 Battery operation	04
P1	Output 1 Polarity Allows setting of the output polarity: 4 output NC n0 output NO NOTE: if the output setting is 00 (Failsafe), keep the value set to n0	n0
02	Output 2 Output 2 signal type, see "Output 1"	03

Display	Function	Default
P2	Output 2 Polarity Output 2 polarity, see parameter regarding "Output 1 Polarity"	no
o3	Output 3 Output 3 signal type, see "Output 1"	19
P3	Output 3 Polarity Output 3 polarity, see parameter regarding "Output 1 Polarity"	no
o4	Output 4 Output 4 signal type, see "Output 1"	01
P4	Output 4 Polarity Output 4 polarity, see parameter regarding "Output 1 Polarity"	no
o5	Output 5 Output 5 signal type, see "Output 1"	02
P5	Output 5 polarity Output 5 polarity, see parameter for "Output 1 polarity"	no
o6	Output 6 Output 6 signal type, see "Output 1"	04
P6	Output 6 polarity Output 6 polarity, see parameter for "Output 1 polarity"	no
o7	Integrated flashing lamp operating mode Lets you choose between two operating modes for the integrated flashing lamp (if present) connected to output J15. 01 "Traffic light" mode (steady green when paused/open, flashing red when moving, steady red when closed) 02 "Flashing lamp" mode (flashing red when bar is moving, off in all other cases)	01
RS	Service request (linked to the following two functions): If activated, at the end of the countdown (which can be set with the two following "Cycle Programming" functions) it activates the LAMP output for 4 sec every 30 sec (service request). It can be useful for setting programmed maintenance work. y Active no Disabled	no
nc	Cycle programming in thousands: Is used to set a countdown of the system operation cycles; the value can be set from 0 to 99 (thousands of cycles). The value displayed is updated with the succession of the cycles, interacting with the value of nL (99 decrements of nc correspond to 1 decrement of nL). The function can be used, together with nL, to verify the use of the system and for use of "Service Request".	00

Display	Function	Default
nL	Cycle programming in hundreds of thousands: Is used to set a countdown of the system operation cycles; the value can be set from 0 to 99 (hundreds of thousands of cycles). The value displayed is updated with the succession of the cycles, interacting with the value of nc. (1 decrement of nL corresponds to 99 decrements of nc). The function can be used, together with nc, to verify the use of the system and for use of "Service Request".	01
St	SYSTEM STATUS: This allows you to choose whether to quit the program and save the data. y = quit and save the data no = quit without saving the data On quitting the program, press the F key to display again the status of the automated system. You can go to St at any time by pressing F and then-	

6.1 Configuring the loop detector

The E680 board features an integrated metal mass detector for the induction detection of vehicles.

6.1.1 Specifications:

- Galvanic separation between the detector electronics and the loop electronics
- Automatic alignment of the system immediately following activation
- Continuous resetting of the frequency drifts
- Sensitivity independent of loop inductivity
- Adjustment of the loop work frequency with automatic selection
- Loop in detection indication on the LED display
- Loop status available on outputs

6.1.2 Connection:

Connect the loops according to the layout on Fig. 22

- Terminals 24 - 25 for LOOP 1 = loop with opening function;
- Terminals 26 - 27 for LOOP 2 = loop with closing and/or safety when closing function.

For more information on the effect of the loop signals on the automated system, refer to the logics tables in paragraph 11 "OPERATING LOGICS TABLE".

To enable the on board loops, enter Basic configuration mode and set parameters L1 and L2 on y according with the number of connected loops. If only one loop is installed, enable only the corresponding programming step.

The loop detector operating status is indicated by the DL3 and DL4 status LEDs.

6.1.3 Calibration

Each time the E680 board is powered, the integrated loop detector performs a calibration of the connected loops. Therefore, you can perform calibration by turning off power to the board for at least 10 seconds and then turning it back on. From the barrier status display, you can press, at any time, SW4/CAL1 to calibrate the loop connected to the LOOP 1 input or SW5/CAL2 to calibrate the loop connected to the LOOP2 input.

Calibration is highlighted by the board diagnostics by flashing LEDs DL3 and DL4, and when calibration is completed, they will indicate the loop detection status, if connected. The other signals provided by the board diagnostics are described in the following table:

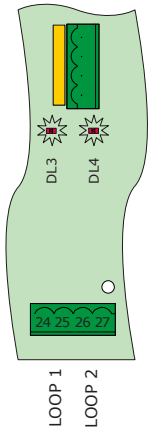

LED Status	LOOP Status
Off	Loop clear
On	Loop engaged
Flashing (0.5 s)	Loop calibration in progress
Rapid flashing	Loop short circuit
Slow flashing (5 s)	No loop or loop interrupted
Two flashes (every 5 s)	Non-conforming loop (resistance or inductance values out of range)



If one or both magnetic loops are not installed, the loop detector, following a first attempt to calibrate, will keep the status LEDs flashing every 5 seconds (as shown in the above table).

Recommended loop inductivity range: 40-400 uH

6.1.4 Adjusting sensitivity

By adjusting the sensitivity of the loop detector, you determine the variation of inductivity, for each channel, that a vehicle must cause in order to activate the corresponding detector output. Sensitivity is adjusted separately for each channel using the two parameters S1 and S2 in Basic configuration

6.1.5 Making the loops

The loop must be laid at least 6" (15cm) from fixed metal objects, at least 20" (50cm) from moving metal objects and no more than 2" (5cm) from the surface of the final paving. Use a standard AWG 16 unipolar cable (direct buried cable must have double insulation). Make a preferably square or rectangular loop by preparing a PVC cable duct or by tracing the paving, as shown in figure 16 (the corners must be cut at a 45° angle to avoid cable breaks). Lay the cable using the number of windings shown in the table. The two ends of the cable must be twisted together (at least 6 times per foot) from the loop to the E680 board. Avoid splicing a cable (if necessary, solder the conductors and seal the splice using a heat-shrinking tubing) and keep it separate from the mains power lines.

Loop Perimeter	Nr. of Windings
less than 10 ft	6
from 10 to 13 ft	5
from 13 to 20 ft	4
from 20 to 40 ft	3
more than 40 ft	2

6.2 Expert Configuration

With the EXPERT configuration the operating logics previously programmed with Basic and Advanced configuration can be further customized.



Before making changes at this level, be certain that the steps you wish to change and their effect on the automated system are fully understood.



After changing any of the third-level parameters the \square parameter of the first-level programming will show the value \square

To access EXPERT configuration, **press F and, holding it, press + for approximately 10 seconds.**

The use of F, + and - in this menu is the same as in the other two programming levels

Display	Function	Setting
<p>"EXPERT" CONFIGURATION F + + 10 sec</p>		
01	If this function is activated, automatic closing occurs after the pause time.	\surd = automatic closing \square = disabled
02	If this function is activated, two distinct input operation mode is obtained: OPEN for opening and CLOSED for closing.	\surd = 2-input operation \square = disabled
03	Activation of recognition of the OPEN and CLOSE input levels (maintained command) . That is to say, the board recognises the level (if, for example, with OPEN held, you press STOP, when the latter is released, the automated system will continue to open). If 03 is disabled the board commands a manoeuvre only if there is an input variation.	\surd = level recognition \square = status variation recognition
04	Activation of DEAD-MAN opening (command always pressed). Releasing the OPEN command will stop operation	\surd = active \square = disabled

05	When this function is activated, the OPEN command during opening will stop movement. If parameter 06 is no the system is ready for opening. If parameter 06 is Y the system is ready for closing.	Y = when opening it stops no = disabled
06	When this function is activated, the OPEN command during opening reverses movement. If parameters 05 and 06 are no OPEN will have no effect during opening.	Y = when opening it reverses no = disabled
07	When this function is activated, the OPEN command during pause stops operation. If parameters 07 and 08 are no OPEN resets the pause time	Y = when in pause it stops no = disabled
08	When this function is activated, the OPEN command during pause causes closing. If parameters 07 and 08 are no OPEN resets the pause time.	Y = when in pause it closes no = disabled
09	When this function is activated, the OPEN command during closing stops operation, otherwise it reverses movement.	Y = stops no = reverses
10	Activation of DEAD-MAN closing (command always pressed). Releasing the CLOSE command will stop operation	Y = active no = disabled
11	When this function is activated, the CLOSE command has priority over OPEN, otherwise OPEN has priority over CLOSE.	Y = active no = disabled
12	When this function is activated, the CLOSE command commands closing when released. As long as CLOSE is activated, the unit stays in closing pre-flashing.	Y = closes when released no = closes immediately
13	When this function is activated, the CLOSE command during opening stops operation, otherwise the CLOSE command commands reverse immediately or when opening is completed (see also parameter 14)	Y = CLOSE stops no = CLOSE reverses
14	When this function is activated, and if parameter 13 is no, the CLOSE command commands immediate closing at the end of the opening cycle (stores CLOSE). If parameters 13 and 14 are no CLOSE commands immediate closing.	Y = closes at the end of opening no = immediate closing
15	When this function is activated, with the system blocked by a STOP, a next OPEN moves in the opposite direction. If parameter 15 is no it always closes.	Y = moves in the opposite direction no = always closes
16	When this function is activated, during closing, the CLOSING SAFETIES stop and allow motion to resume when they are disengaged, otherwise they immediately reverse opening.	Y = closes when disengaged no = immediate reverse
17	When this function is activated, the CLOSING SAFETIES command closing when they are disengaged (see also parameter 18).	Y = closing when FSW is disengaged no = disabled
18	When this function is activated, and if parameter 17 is Y, the unit will wait for the opening cycle to end before executing the closing command provided by the CLOSING SAFETIES .	Y = closes at the end of opening no = disabled
19	When this function is activated, during closing, LOOP2 stops and allows motion to resume when it is disengaged, otherwise it immediately reverses opening.	Y = closes when disengaged no = immediate reverse
20	When this function is activated, LOOP2 commands closing when it is disengaged (see also parameter 21).	Y = closes if LOOP2 is clear no = disabled
21	When this function is activated, and if parameter 20 is Y, the unit will wait for the opening cycle to end before executing the closing command provided by LOOP2 .	Y = closes at the end of opening no = disabled
22	When this function is activated: in case of a blackout, once electrical power has been restored, if an OPEN command is not active the automated system recloses immediately.	Y = active no = disabled
23	LOOP 1 commands opening and, once completed, it closes if disengaged (useful in case of vehicle backing-up with consecutive loops). If disabled, when LOOP 1 is disengaged, it does not close.	Y = closes if LOOP1 clear no = disabled
24	When this function is activated, an open or close command is only carried out after the safeties have been disengaged.	Y = active no = disabled
25	A.D.M.A.P. function When this function is activated, the result is operation of safeties compliant with French regulations .	Y = active no = disabled
26	When this function is activated, the CLOSING SAFETIES during closing stop and reverse movement when they are disengaged, otherwise they reverse immediately.	Y = stops and reverses when disengaged. no = reverses immediately.
27	DO NOT CHANGE	no
28	DO NOT CHANGE	no
29	DO NOT CHANGE	no
30	When this function is activated, the LOOP1 commands are prioritised rather than the LOOP2 commands.	Y = active no = disabled

<p>R0</p>	<p>HOLD CLOSE / HOLD OPEN function When this function is activated, the automated system will monitor the position of the arm at set intervals (see parameter R1). If the arm is not completely closed or completely open (depending on the logical condition of the board), the automated system will command a CLOSE or OPEN movement to bring the arm back to the correct position, for a maximum of 3 seconds. If, when the 3 seconds have elapsed, the bar does not go back to completely closed/open position (e.g. because the bar is blocked), the function will be disabled until the next OPEN command is received.</p>	<p>4</p>
<p>R1</p>	<p>HOLD CLOSE / HOLD OPEN function activation time This parameter indicates the time interval between two activations of the HOLD OPEN / HOLD CLOSE function, expressed in minutes. (from 00 to 99)</p>	<p>60</p>
<p>r1</p>	<p>Loop 1 frequency reading This menu item lets you verify the reading of the current oscillation frequency of the loop connected to the Loop 1 input. The indication should be read as follows: First digit: tens (kHz) Second digit: units (kHz) Decimal point: hundreds (kHz) For example, the reading 05. refers to a reading of 105 kHz</p> <p>Read-only parameter</p>	
<p>r2</p>	<p>Loop 2 frequency reading This menu item lets you verify the reading of the current oscillation frequency of the loop connected to the Loop 2 input. (see parameter r1 for explanations on how to read the indicated value)</p> <p>Read-only parameter</p>	
<p>F1</p>	<p>Loop 1 frequency selection This parameter lets you set an oscillation frequency specific to the loop connected to the Loop 1 input, or lets the system choose the most adequate setting among the 4 available.</p> <p>R Automatic selection 1-2-3-4 Frequency 1-2-3-4</p> <p>Note: When you exit the Advanced configuration menu after having changed the loop operation frequency setting, the system will be recalibrated. This will provide an updated frequency reading once you re-enter the menu to consult the values of parameters r1 or r2</p>	<p>R</p>
<p>F2</p>	<p>Loop 2 frequency selection This parameter lets you set an oscillation frequency specific to the loop connected to the Loop 2 input, or lets the system choose the most adequate setting among the 4 available.</p> <p>R Automatic selection 1-2-3-4 Frequency 1-2-3-4</p> <p>Note: When you exit the Advanced configuration menu after having changed the loop operation frequency setting, the system will be recalibrated. This will provide an updated frequency reading once you re-enter the menu to consult the values of parameters r1 or r2</p>	<p>R</p>
<p>h1</p>	<p>LOOP 1 holding time Is used to set presence time on loop 1. When this time has elapsed, the board will self-calibrate and signal "loop clear" (LED DL3 off). When the board is turned on, an automatic reset is carried out.</p> <p>4 5 minutes no infinite</p>	<p>no</p>
<p>h2</p>	<p>LOOP 2 holding time Is used to set presence time on loop 2. When this time has elapsed, the board will self-calibrate and signal "loop clear" (LED DL4 off). When the board is turned on, an automatic reset is carried out.</p> <p>4 5 minutes no infinite</p>	<p>no</p>

H1	Loop 1 articulated lorry function This function lets you increase the level of sensitivity at the time of detection, to allow correct detection even in case of very tall vehicles or during the transit of a tractor and trailer. y enabled no disabled	y
H2	Loop 2 articulated lorry function This function lets you increase the level of sensitivity at the time of detection, to allow correct detection even in case of very tall vehicles or during the transit of a tractor and trailer. y enabled no disabled	y
t	Work time (time-out) Maximum work time of the automated system before the motor stops, if the open or close position is not reached. The value can be set from 0 to 59 sec. in one second steps. Next, the display changes to minutes and tenths of a second (separated by a decimal point) and time is adjusted in 10-second steps up to the maximum value of 4.1 minutes.	30
dr	Red light brightness (OUT 5) Changing this value increases or decreases the output voltage for OUT 5, changing the brightness of the rope light.	04
dG	Green light brightness (OUT 6) Changing this value increases or decreases the output voltage for OUT 6, changing the brightness of the rope light.	04
St	STATUS OF THE AUTOMATED SYSTEM: Exit from programming, storage of data and automated system status display.	

6.3 Pre-Defined Parameter Sets

The table below shows, for each set of pre-defined parameters, the values that they will load in the board memory.

Basic Configuration

cF	01	02	03	04	05	06
dF	y	y	y	y	y	y
Ct	MA	MA	MA	MA	MA	MA
bu	no	no	no	no	no	no
L0	E	E	E	E	E	E
PA	20	20	20	20	20	20
So	10	10	10	10	10	10
Sc	10	05	05	04	02	02
L1	no	no	no	no	no	no
L2	no	no	no	no	no	no
S1	05	05	05	05	05	05
S2	05	05	05	05	05	05

Advanced Configuration

The following table shows, for each set of pre-defined parameters, the values that they will load in the board memory, in advanced configuration.

cF	01	02	03	04	05	06
F0	25	25	30	28	30	40
F0	25	25	30	28	30	40
PF	no	no	no	no	no	no
tP	00	00	00	00	00	00
oc	30	30	30	30	30	30
F5	no	no	no	no	no	no
o1	04	04	04	04	04	04
P1	no	no	no	no	no	no
o2	03	03	03	03	03	03
P2	no	no	no	no	no	no
o3	19	19	19	19	19	19
P3	no	no	no	no	no	no
o4	01	01	01	01	01	01
P4	no	no	no	no	no	no
o5	02	02	02	02	02	02
P5	no	no	no	no	no	no
o6	04	04	04	04	04	04
P6	no	no	no	no	no	no
o7	01	01	01	01	01	01
AS	no	no	no	no	no	no
nc	00	00	00	00	00	00
nC	00	00	00	00	00	00

6.4 "Expert" default parameters

The following table contains the pre-defined settings that characterize the various operation logics.

Step	A	A1	E	P	PA	Cn	Ca	C
01	Y	Y	N	N	Y	N	Y	N
02	N	N	N	Y	Y	Y	Y	Y
03	N	N	N	N	N	N	N	N
04	N	N	N	N	N	N	N	Y
05	N	N	Y	N	N	N	N	N
06	N	N	Y	N	N	N	N	N
07	N	N	N	N	N	N	N	N
08	N	N	N	N	N	N	N	N
09	N	N	N	N	N	N	N	N
10	N	N	N	N	N	N	N	Y
11	N	N	N	N	N	N	N	N
12	N	N	N	Y	Y	N	N	N
13	N	N	N	N	N	N	N	N
14	N	N	N	Y	Y	Y	Y	N
15	N	N	N	N	N	N	N	N
16	N	N	N	Y	Y	N	N	N
17	N	Y	N	N	N	N	N	N
18	N	Y	N	N	N	N	N	N
19	N	N	N	Y	Y	N	N	N
20	N	Y	N	Y	Y	Y	Y	N
21	N	Y	N	Y	Y	Y	Y	N
22	N	N	N	N	N	N	N	N
23	N	N	N	Y	Y	N	N	N
24	N	N	N	N	N	N	N	N
25	N	N	N	N	N	N	N	N
26	N	N	N	N	N	N	N	N
27	N	N	N	N	N	N	N	N
28	N	N	N	N	N	N	N	N
29	N	N	N	N	N	N	N	N
30	N	N	N	N	N	Y	Y	N

7. START-UP

7.1 Verifying the diagnostic LEDs

Before starting the operator verify that the status of the diagnostic LEDs corresponds to the logic. Said status must coincide with the indications in Fig. 27, which reflects that of an operator in CLOSED position and ready to open.

The FSW, STOP and EMR LEDs are safety inputs with NC contacts, therefore the related LEDs must be ON when the automated system is at rest, and go off when the device connected is engaged.

The OPEN and CLOSE inputs are NO contact inputs, therefore the related LEDs must be OFF when the automated system is at rest, and go on when the device connected is active.

The BUS status must correspond to DL2 (green) on steady and DL1 (red) off. The BUS menu of the Basic configuration must display the indication shown to the side confirming the fact that there are no engaged photocells or active pulse generators.

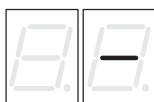
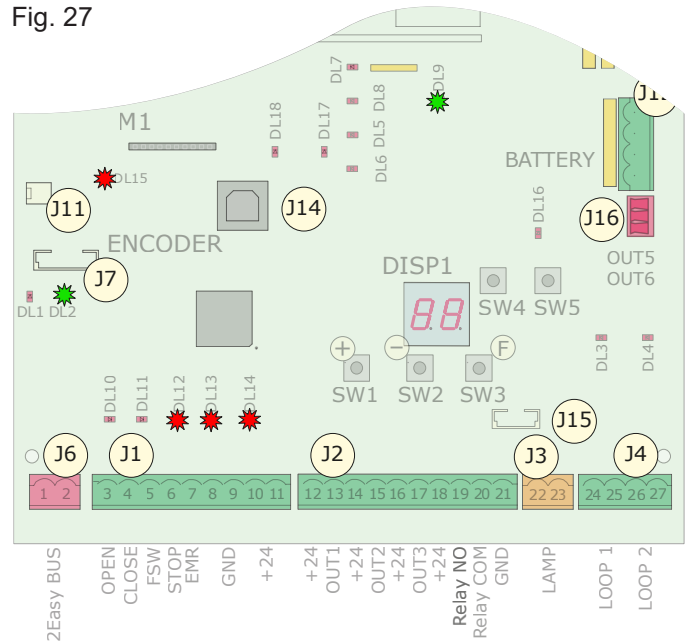

Fig. 27



7.2 Setup

Before being put into operation, the E680 board requires a setup procedure during which the automated system determines the rotation angle of the arm and consequently its travel. These measurements allow correct management of motor decelerations and acceleration ramps.

At first start-up the board will signal the need for a setup cycle, by displaying a flashing 50.

For setup, proceed as follows:

- Using the parameter "Mt" in Basic configuration mode, check that the opening / closing movement corresponds to the pressed key (+ opens - closes); if not, go to the motor wiring and reverse the two conductors L1 and L3, as shown below.
- Bring the arm to the fully closed position with the "Mt" parameter of the Base configuration level or by operating the manual release device as indicated in Par. 5.
- Access Base programming and repeatedly press the F button until you reach the parameter \overline{L} , then press the + and - buttons at the same time until the operator's arm begins opening slowly, then release the buttons.
- During setup, a flashing -- indication will appear on the display.
- Upon reaching the fully open position, the operator will stop automatically.
- The operator will then begin the arm closing movement.
- Upon reaching the closed position, the operator will stop automatically.
- Press the F button to exit the procedure, and confirm you wish to save the data with the parameter \overline{S} . Check that the status of the operator shown on the display is 00 (closed) and that the arm is in the closed position. If the arm is open and the display is showing 00, check / adjust the correct direction of movement of the motor again as in step 1 of the procedure.

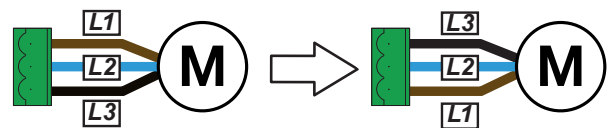

8. TESTING THE AUTOMATED SYSTEM

Once programming is completed, verify that the system is operating correctly and that the safety devices work properly, conforming to the current safety standards.

9. MASTER/SLAVE CONFIGURATION

If the installation requires the gate area being covered by two opposing barriers, a Master / Slave configuration may be used for the boards which will activate the two barriers. This configuration permits connection of the command and safety signals to be simplified (they are all connected to just one board), also ensuring perfect synchronisation of the two automated systems.

“MASTER device” means the board to which all the pulse generators and safety devices are connected.

“SLAVE device” means the one controlled by the MASTER via the 2Easy BUS.

Setting the two boards as master and slave must first of all be performed in base level programming by setting the value $Ct = MA$ on the master board and $Ct = SL$ on the slave board.

The master and slave operators communicate via the 2Easy BUS. Connect them as shown below:

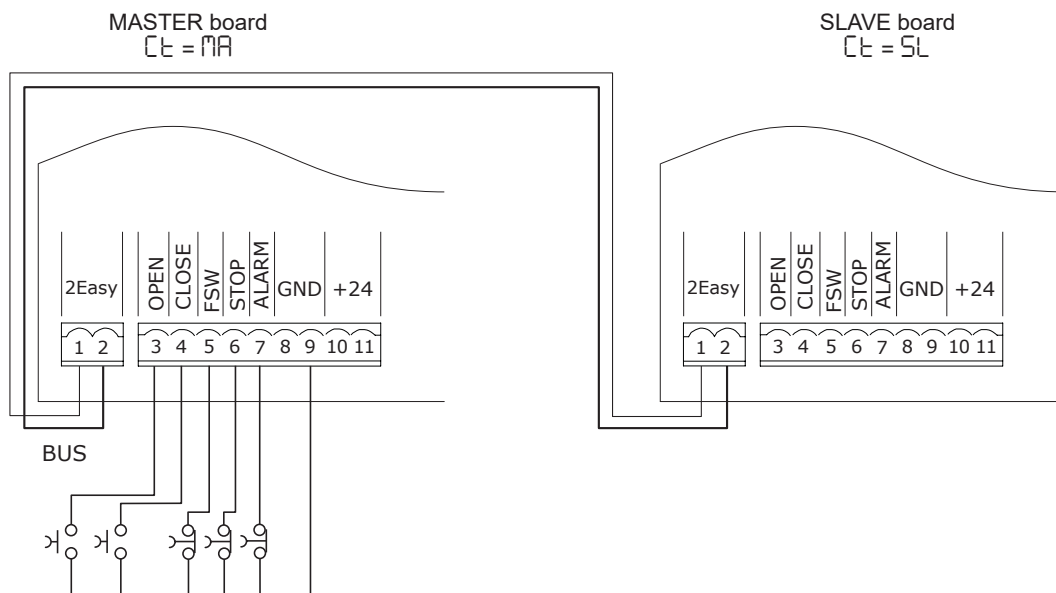

Any input signal present on terminal J1 of the SLAVE board will be ignored; connect all control and safety signals to the MASTER board

When the BUS connection is made, the SLAVE automation system will synchronise with the MASTER. Ensure there are no people or other obstacles in the range of action of the arm.

To set up the operators, proceed as follows:

1. Check that the open/close movement is consistent with the button pressed (+ / -) on both barriers via the “Mt” parameter of the base configuration level; if not, the motor wiring must be adjusted by inverting the two conductors L1 and L3
2. Bring the arm to the fully closed position with the “Mt” parameter of the Base configuration level or by operating the manual release device.
3. Access Base programming on the MASTER device and repeatedly press the **F** button until you reach the parameter Ct , then press the **+** and **-** buttons at the same time until both operator arms begin opening slowly.
4. Upon reaching the fully open position, both operators will stop automatically.
5. The operators will then begin the arm closing movement.
6. Upon reaching the closed position, the movement will stop automatically.
7. Press the **F** button to exit the procedure, and confirm you wish to save the data. Check that the current status of the operators shown on both displays is $\square\square$ (closed) and that the arm is in the closed position. If the arm is open and the display is showing $\square\square$, check / adjust the correct direction of movement of the motor again as in step 1 of the procedure.

During setup, a flashing -- indication will appear on the display

In MASTER / SLAVE operation mode the two devices will remain independent in terms of their configuration, the forces and speed of movement, the loop detectors and configurable outputs.

The MASTER will, however, overwrite the operational logic on the SLAVE and reading of the SLAVE inputs will be prevented.

When a device is configured as SLAVE, the unused parameters will be hidden in the configuration menus. The following table indicates the structure of the menus of a board configured as a SLAVE device.

Base Configuration

cF	01	02	03	04	05	06
dF	y	y	y	y	y	y
Ct	MA	MA	MA	MA	MA	MA
bu	no	no	no	no	no	no
So	10	10	10	10	10	10
Sc	10	05	05	04	02	02
S1	05	05	05	05	05	05
S2	05	05	05	05	05	05

Advanced Configuration

cF	01	02	03	04	05	06
F0	25	25	30	28	30	40
FC	25	25	30	28	30	40
oc	30	30	30	30	30	30
o1	04	04	04	04	04	04
P1	no	no	no	no	no	no
o2	03	03	03	03	03	03
P2	no	no	no	no	no	no
o3	19	19	19	19	19	19
P3	no	no	no	no	no	no
o4	01	01	01	01	01	01
P4	no	no	no	no	no	no
o5	02	02	02	02	02	02
P5	no	no	no	no	no	no
o6	04	04	04	04	04	04
P6	no	no	no	no	no	no
o7	01	01	01	01	01	01
nc	00	00	00	00	00	00
nC	00	00	00	00	00	00

Expert Configuration

cF	01	02	03	04	05	06
AO	y	y	y	y	y	y
AI	01	01	01	01	01	01
r1	--	--	--	--	--	--
r2	--	--	--	--	--	--
F1	A	A	A	A	A	A
F2	A	A	A	A	A	A
h1	no	no	no	no	no	no
h2	no	no	no	no	no	no
H1	y	y	y	y	y	y
H2	y	y	y	y	y	y
t	30	30	30	30	30	30
dr	04	04	04	04	04	04
dG	04	04	04	04	04	04

10. INTERLOCK

The interlock function enables two in-line barriers to be managed so that opening of one is subordinated to closing of the other. Operation can be one-way or two-way.

For in-line barriers, set OUT1 INTERLOCK to parameter 18 (see 2nd LEVEL PROG.) on both boards and connect them as in figure.

o1 = 18
P1 = no

o1 = 18
P1 = no

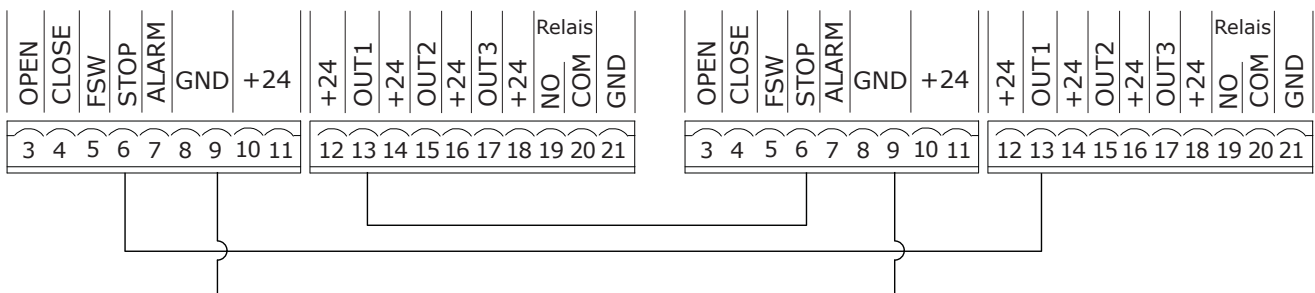

11. OPERATING LOGICS TABLE

Tab. 1/a

LOGIC "A"	PULSES					
AUTOMATED SYSTEM STATUS	OPEN A	CLOSE	STOP	FSW	LOOP 1	LOOP 2
CLOSED	opens and closes after the pause time	no effect	no effect (opening inhibited)	no effect	opens and closes after the pause time	no effect
WHEN OPENING	no effect	immediately reverses to closing	blocks operation	no effect	no effect	no effect
OPEN IN PAUSE	resets pause time	closes	blocks operation	resets pause time (closing inhibited)	resets pause time	resets pause time (closing inhibited)
WHEN CLOSING	immediately reverses to opening	no effect	blocks operation	immediately reverses to opening	immediately reverses to opening	immediately reverses to opening
BLOCKED	closes	closes	no effect (opening and closing inhibited)	no effect (closing inhibited)	opens and closes after the pause time	no effect (closing inhibited)

Tab. 1/b

LOGIC "A1"	PULSES					
AUTOMATED SYSTEM STATUS	OPEN A	CLOSE	STOP	FSW	LOOP 1	LOOP 2
CLOSED	opens and closes after the pause time	no effect	no effect (opening inhibited)	no effect	opens and closes after the pause time	no effect
WHEN OPENING	no effect	immediately reverses to closing	blocks operation	closes immediately after opening is completed	no effect	closes immediately after opening is completed
OPEN IN PAUSE	resets pause time	closes	blocks operation	closes	resets pause time	closes when disengaged
WHEN CLOSING	immediately reverses to opening	no effect	blocks operation	immediately reverses to opening	immediately reverses to opening, closes at the end of pause	immediately reverses to opening, closes again once opening is completed
BLOCKED	closes	closes	no effect (opening and closing inhibited)	inhibits closing	opens and closes after the pause time	no effect (closing inhibited)

Tab. 1/c

LOGIC "E"	PULSES					
AUTOMATED SYSTEM STATUS	OPEN A	CLOSE	STOP	FSW	LOOP 1	LOOP 2
CLOSED	opens	no effect	no effect (opening inhibited)	no effect	opens	no effect
WHEN OPENING	blocks operation	immediately reverses to closing	blocks operation	no effect	no effect	no effect
OPEN	closes	closes	no effect (closing inhibited)	no effect (closing inhibited)	no effect	no effect (closing inhibited)
WHEN CLOSING	immediately reverses to opening	no effect	blocks operation	immediately reverses to opening	immediately reverses to opening	immediately reverses to opening
BLOCKED	closes	closes	no effect (opening and closing inhibited)	no effect (closing inhibited)	opens	no effect (closing inhibited)

⇒ In brackets, the effects on the other inputs when the pulse is active

Tab. 1/d

LOGIC "P"	PULSES					
AUTOMATED SYSTEM STATUS	OPEN A	CLOSE	STOP	FSW	LOOP 1	LOOP 2
CLOSED	opens	no effect	no effect (opening inhibited)	no effect	opens and once opening is completed closes if disengaged	no effect
WHEN OPENING	no effect	closes immediately after opening is completed	blocks operation	no effect	no effect	closes immediately after opening is completed
OPEN	no effect (closing inhibited)	closes	no effect (closing inhibited)	no effect (closing inhibited)	prevents closing	closes when disengaged
WHEN CLOSING	immediately reverses to opening	no effect	blocks operation	blocks and when disengaged continues to close	immediately reverses to opening, and once opening is completed closes if disengaged	blocks and when disengaged continues to close
BLOCKED	opens	closes	no effect (opening and closing inhibited)	no effect (closing inhibited)	opens and once opening is completed closes if disengaged	no effect (closing inhibited)

Tab. 1/e

LOGIC "PA"	PULSES					
AUTOMATED SYSTEM STATUS	OPEN A	CLOSE	STOP	FSW	LOOP 1	LOOP 2
CLOSED	opens and closes after the pause time	no effect	no effect (opening inhibited)	no effect	opens and once opening is completed closes if disengaged	no effect
WHEN OPENING	no effect	closes immediately after opening is completed	blocks operation	no effect	no effect	closes immediately after opening is completed
OPEN IN PAUSE	resets pause time	closes	blocks operation	resets pause time (closing inhibited)	resets pause time	closes when disengaged
WHEN CLOSING	immediately reverses to opening	no effect	blocks operation	blocks and when disengaged continues to close	immediately reverses to opening, and once opening is completed closes if if disengaged	blocks and when disengaged continues to close
BLOCKED	opens and closes after the pause time	closes	no effect (opening and closing inhibited)	no effect (closing inhibited)	opens and once opening is completed closes if disengaged	no effect (closing inhibited)

Tab. 1/f

LOGIC "Cn"	PULSES					
AUTOMATED SYSTEM STATUS	OPEN A	CLOSE	STOP	FSW	LOOP 1	LOOP 2
CLOSED	opens	no effect	no effect (opening inhibited)	no effect	opens	no effect
WHEN OPENING	no effect	closes immediately after opening is completed	blocks operation	no effect	no effect	closes immediately after opening is completed
OPEN	no effect (closing inhibited)	closes	no effect (closing inhibited)	no effect (closing inhibited)	no effect	closes when disengaged
WHEN CLOSING	immediately reverses to opening	no effect	blocks operation	reverses to opening and closes after pause time	immediately reverses to opening	immediately reverses to opening
BLOCKED	opens	closes	no effect (opening and closing inhibited)	no effect (closing inhibited)	opens	no effect (closing inhibited)

↻ In brackets, the effects on the other inputs when the pulse is active

Tab. 1/g

LOGIC "CA"	PULSES					
AUTOMATED SYSTEM STATUS	OPEN A	CLOSE	STOP	FSW	LOOP 1	LOOP 2
CLOSED	opens and closes after the pause time	no effect	no effect (opening inhibited)	no effect	opens and closes after the pause time	no effect
WHEN OPENING	no effect	closes immediately after opening is completed	blocks operation	no effect	no effect	closes immediately after opening is completed
OPEN IN PAUSE	resets pause time	closes	blocks operation	resets pause time (closing inhibited)	resets pause time	closes when disengaged
WHEN CLOSING	immediately reverses to opening	no effect	blocks operation	reverses to opening and closes after pause time	immediately reverses to opening	immediately reverses to opening
BLOCKED	opens and closes after the pause time	closes	no effect (opening and closing inhibited)	no effect (closing inhibited)	opens and closes after the pause time	no effect (closing inhibited)

Tab. 1/h

LOGIC "C"	MAINTAINED COMMANDS		PULSES			
AUTOMATED SYSTEM STATUS	OPEN A	CLOSE	STOP	FSW	LOOP 1	LOOP 2
CLOSED	opens	no effect	no effect (opening inhibited)	no effect	no effect	no effect
WHEN OPENING	/	no effect	blocks operation	no effect	no effect	no effect
OPEN	no effect (closing inhibited)	closes	blocks operation	no effect	no effect (closing inhibited)	no effect (closing inhibited)
WHEN CLOSING	immediately reverses to opening	/	blocks operation	blocks operation	blocks operation	blocks operation
BLOCKED	opens	closes	no effect (opening and closing inhibited)	no effect (closing inhibited)	no effect (closing inhibited)	no effect (closing inhibited)

↻ In brackets, the effects on the other inputs when the pulse is active

LIMITED WARRANTY

To the original purchaser only:

FAAC International, Inc., warrants, for twenty-four (24) months from the date of invoice, the gate operator systems and other related systems and equipment manufactured by FAAC S.p.A. and distributed by FAAC International, Inc., to be free from defects in material and workmanship under normal use and service for which it was intended provided it has been properly installed and operated.

FAAC International, Inc.'s obligations under this warranty shall be limited to the repair or exchange of any part of parts manufactured by FAAC S.p.A. and distributed by FAAC International, Inc. Defective products must be returned to FAAC International, Inc., freight prepaid by purchaser, within the warranty period. Items returned will be repaired or replaced, at FAAC International, Inc.'s option, upon an examination of the product by FAAC International, Inc., which discloses, to the satisfaction of FAAC International, Inc., that the item is defective. FAAC International, Inc. will return the warranted item freight prepaid. The products manufactured by FAAC S.p.A. and distributed by FAAC International, Inc., are not warranted to meet the specific requirements, if any, of safety codes of any particular state, municipality, or other jurisdiction, and neither FAAC S.p.A. or FAAC International, Inc., assume any risk or liability whatsoever resulting from the use thereof, whether used singly or in combination with other machines or apparatus.

Any products and parts not manufactured by FAAC S.p.A. and distributed by FAAC International, Inc., will carry only the warranty, if any, of the manufacturer. This warranty shall not apply to any products or parts thereof which have been repaired or altered, without FAAC International, Inc.'s written consent, outside of FAAC International, Inc.'s workshop, or altered in any way so as, in the judgment of FAAC International, Inc., to affect adversely the stability or reliability of the product(s) or has been subject to misuse, negligence, or accident, or has not been operated in accordance with FAAC International, Inc.'s or FAAC S.p.A.'s instructions or has been operated under conditions more severe than, or otherwise exceeding, those set forth in the specifications for such product(s). Neither FAAC S.p.A. nor FAAC International, Inc., shall be liable for any loss or damage whatsoever resulting, directly or indirectly, from the use or loss of use of the product(s). Without limiting the foregoing, this exclusion from liability embraces a purchaser's expenses for downtime or for making up downtime, damages for which the purchaser may be liable to other persons, damages to property, and injury to or death of any persons.

FAAC S.p.A. or FAAC International, Inc., neither assumes nor authorizes any person to assume for them any other liability in connection with the sale or use of the products of FAAC S.p.A. or FAAC International, Inc. The warranty herein above set forth shall not be deemed to cover maintenance parts,

including, but not limited to, hydraulic oil, filters, or the like. No agreement to replace or repair shall constitute an admission by FAAC S.p.A. or FAAC International, Inc., of any legal responsibility to effect such replacement, to make such repair, or otherwise. This limited warranty extends only to wholesale customers who buy directly through FAAC International, Inc.'s normal distribution channels. FAAC International, Inc., does not warrant its products to end consumers.

Consumers must inquire from their selling dealer as to the nature and extent of that dealer's warranty, if any. This warranty is expressly in lieu of all other warranties expressed or implied including the warranties of merchantability and fitness for use. This warranty shall not apply to products or any part thereof which have been subject to accident, negligence, alteration, abuse, or misuse or if damage was due to improper installation or use of improper power source, or if damage was caused by fire, flood, lightning, electrical power surge, explosion, wind storm, hail, aircraft or vehicles, vandalism, riot or civil commotion, or acts of God.