

J200HA

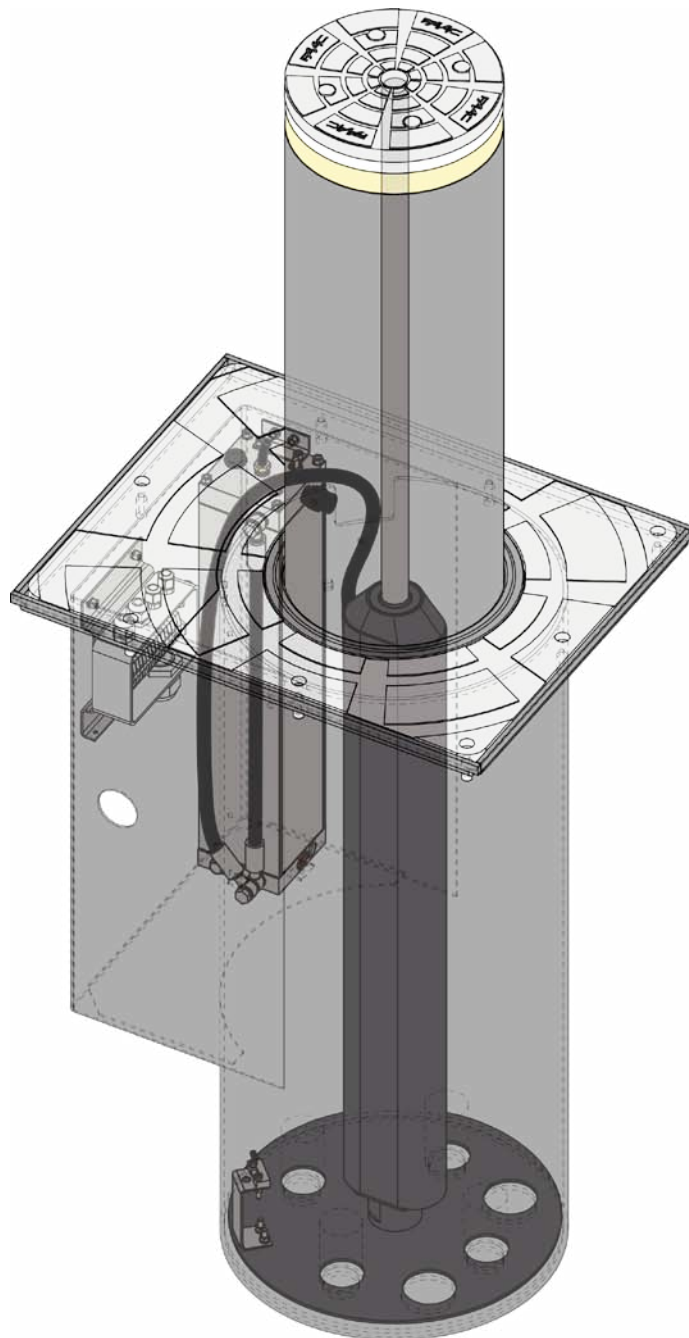

FAAC

CE DECLARATION OF CONFORMITY FOR MACHINES**(DIRECTIVE 2006/42/EC)****Manufacturer:** FAAC S.p.A.**Address:** Via Calari, 10 - 40069 Zola Predosa BOLOGNA - ITALY**Declares that:** the operator mod. J200 HA

is built to be integrated into a machine or to be assembled with other machinery to create a machine under the provisions of Directive 2006/42/EC;

conforms to the essential safety requirements of the following EEC directives:

2006/95/EC Low Voltage Directive

2004/108/EC Electromagnetic Compatibility Directive

and also declares that it is prohibited to put into service the machinery until the machine in which it will be integrated or of which it will become a component has been identified and declared as conforming to the conditions of Directive 2006/42/EEC and subsequent amendments.

Bologna, 01st September 2012

The Managing Director
A. Marcellan

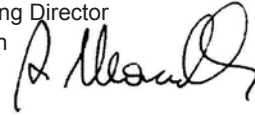
CE DECLARATION OF CONFORMITY FOR MACHINES**Manufacturer:** FAAC S.p.A.**Address:** Via Calari, 10 - 40069 Zola Predosa BOLOGNA - ITALY**Declares that:** the control unit JE275

• conforms to the essential safety requirements of the following EEC directives:

2006/95/EC Low Voltage Directive

2004/108/EC Electromagnetic Compatibility Directive

Additional note:

This product underwent tests in a typical homogenous configuration
(all products manufactured by FAAC S.p.A.).

Bologna, 01st September 2012

The Managing Director
A. Marcellan



WARNINGS FOR THE INSTALLER

GENERAL SAFETY OBLIGATIONS

1. **ATTENTION! To ensure the safety of people, it is important that you read all the following instructions. Incorrect installation or incorrect use of the product could cause serious harm to people.**
2. Carefully read the instructions before beginning to install the product.
3. Do not leave packing materials (plastic, polystyrene, etc.) within reach of children as such materials are potential sources of danger.
4. Store these instructions for future reference.
5. This product was designed and built strictly for the use indicated in this documentation. Any other use, not expressly indicated here, could compromise the good condition/operation of the product and/or be a source of danger.
6. FAAC declines all liability caused by improper use or use other than that for which the automated system was intended.
7. Do not install the equipment in an explosive atmosphere: the presence of inflammable gas or fumes is a serious danger to safety.
8. For non-EU countries, to obtain an adequate level of safety, the Standards mentioned above must be observed, in addition to national legal regulations.
9. FAAC is not responsible for failure to observe Good Technique in the construction of the closing elements to be motorised, or for any deformation that may occur during use.
10. Installation must be performed in compliance with current Standards.
11. Before attempting any job on the system, cut out electrical power.
12. The mains power supply of the automated system must be fitted with an all-pole switch with contact opening distance of 3 mm or greater. Use of a 6A thermal breaker with all-pole circuit break is recommended.
13. Make sure that a differential switch with threshold of 0.03A is fitted upstream of the system.
14. Make sure that the earthing system is perfectly constructed and connect metal parts of the closure to it.
15. The automated system is supplied with an intrinsic anti-crushing safety device consisting of a torque control. Nevertheless, its tripping threshold must be checked as specified in the Standards indicated at point 10.
16. The safety devices (EN 12978 standard) protect any danger areas against **mechanical movement Risks**, such as crushing, dragging, and shearing.
17. Use of at least one indicator-light (i.e. flashing lamp incorporated in the bollard head) is recommended for every system, as well as a warning sign adequately secured to the frame structure, in addition to the devices mentioned at point "16".
18. FAAC declines all liability as concerns safety and efficient operation of the automated system, if system components not produced by FAAC are used.
19. For maintenance, strictly use original parts by FAAC.
20. Do not in any way modify the components of the automated system.
21. The installer shall supply the user with the necessary information for the manual operation of the system in the event of emergency
22. Do not allow children or adults to stay near the product while it is operating.
23. Keep remote controls or other pulse generators away from children, to prevent the automated system from being activated involuntarily.
24. Transit on the bollard is permitted only when the device is completely down.
25. The user must not attempt any kind of repair or direct action whatever and contact qualified personnel only.
26. **Anything not expressly specified in these instructions is not permitted.**

INDEX

1	GENERAL NOTES	3
2	DESCRIPTION AND TECHNICAL SPECIFICATIONS.....	3
3	DIMENSIONS.....	4
4	FACILITIES.....	4
5	ELECTRIC WIRING	6
6	MANUAL OPERATION.....	9
7	AUTOMATIC OPERATION	9
8	MAINTENANCE.....	9
9	ELECTRICAL CONNECTIONS	10
10	PRE-SETTING SELECTION.....	11
11	POSITIONING THE LOOPS	11
12	CONNECTING MORE BOLLARDS	12
	12.1 CONNECTION OF UP TO 4 BOLLARDS ON A SINGLE BOARD.....	12
	12.2 CONNECTION OF UP TO 8 BOLLARDS ON TWO JE275 MASTER – SLAVE CONNECTION.....	12
	12.3 WIRING OF UP TO 4 BOLLARDS ON A SINGLE BOARD	13
	12.4 WIRING OF UP TO 8 BOLLARDS ON TWO JE275 IN MASTER – SLAVE CONNECTION.....	14
13	TROUBLESHOOTING.....	15
14	CLEANING / UNMOUNTING PROCEDURE.....	15

J200 HA BOLLARD

! Please read with the utmost care this manual supplied with the product, since it contains important indications about safety, installation, use and maintenance.

1 GENERAL NOTES

J200HA is an automatic hydraulic traffic bollard. The cylinder is moved by an hydraulic unit located inside the cylinder. The hydraulic release occurs by direct action on the hydraulic unit. As an alternative, if the optional solenoid valve is present, the release occurs automatically in the event of a power cut.

2 DESCRIPTION AND TECHNICAL SPECIFICATIONS

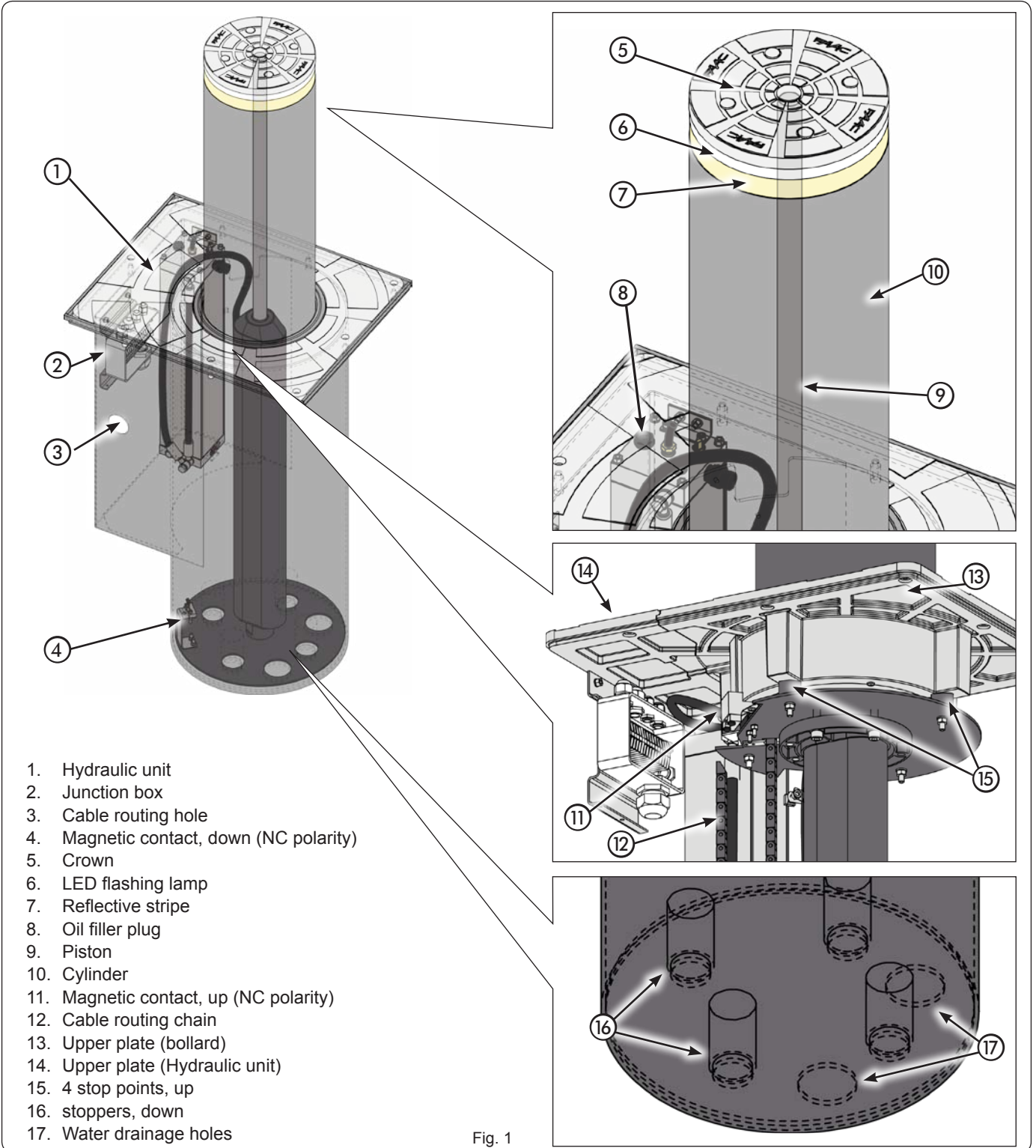
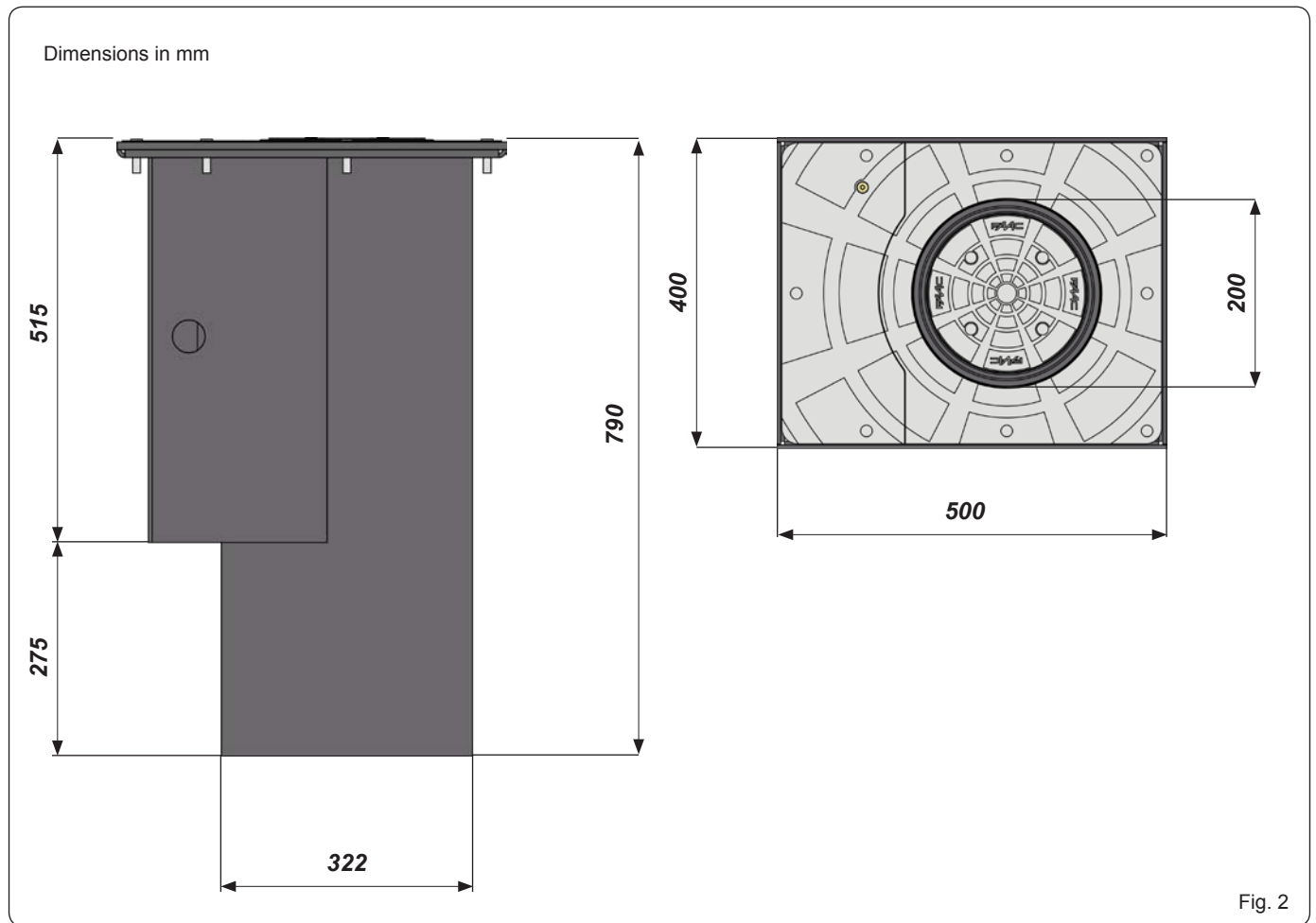

Fig. 1



Tab. A - Technical Specifications

MODEL	J200
Power supply	230 V~ 50 Hz
Max. absorbed power (W)	220
Max. force (N)	1800
Max. pump delivery (lpm)	3
Minimum lifting time (sec)	7
Minimum lowering time (sec)	7
Use temperature (°C)	-15 +55
Weight (Kg)	100
Oil quantity (l)	2,6
Protection class	IP56
Overall dimensions	See Fig.2
Capacitor (3)	16µF - 400V
Use frequency	Semi-Intensive use
R.O.T. at 55°C (min)	40
R.O.T. at 23°C (min)	100

3 DIMENSIONS



4 FACILITIES

-  **Make sure that the place where the bollard is to be installed is not a cavity; if this is the case, partially protect the bollard with a drainage channel equipped with covering grid.**
-  **Dig up to a depth of about 1.1 m**

J200HA

! The dig can be square and have a side of about 1 m (fig. 3). Otherwise it can be carried out using an earth drill with a diameter of 50 cm up to the depth mentioned above and widened in the last 30 cm giving a square shape of 1 m per side

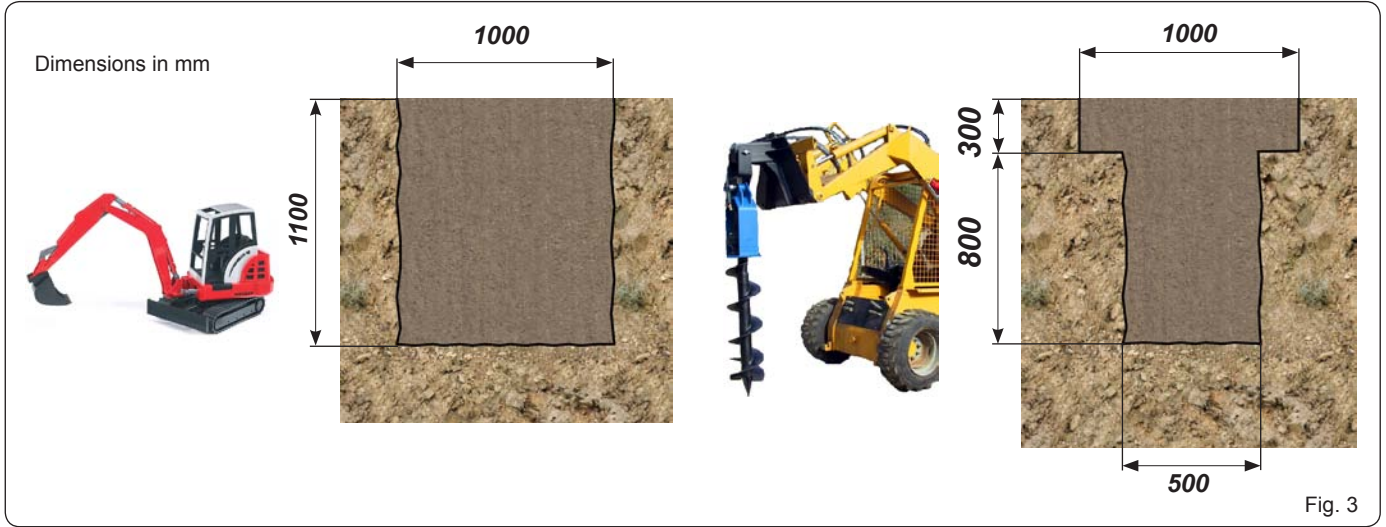

Fig. 3



! Make sure that the ground is able to absorb water: pour about 40 l water and evaluate if draining requires less than 30 minutes. If this is not the case, discharge rain water by means of a pipeline with a diameter of 60mm connected to the drainage system or, as an alternative, connected to a pit, equipped with a drainage system (such as a motor pump), having a depth greater than the pit for the collection and drainage of rain water

! Introduce gravel (grain diameter: approx. 20 mm.) to obtain a thickness of about 30 cm, taking care to compact it well to avoid future settlements

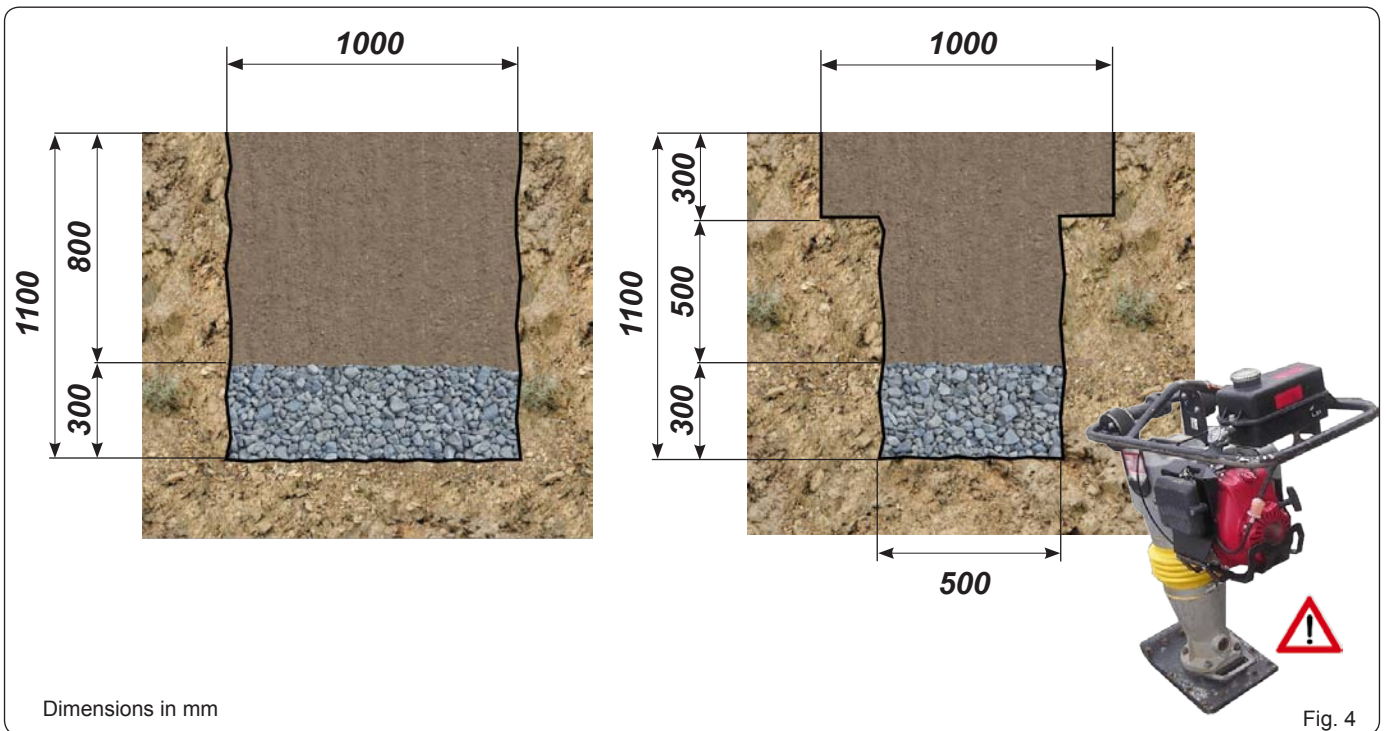
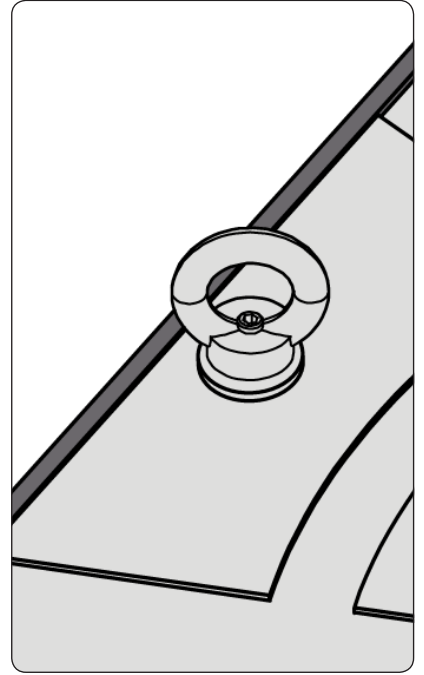
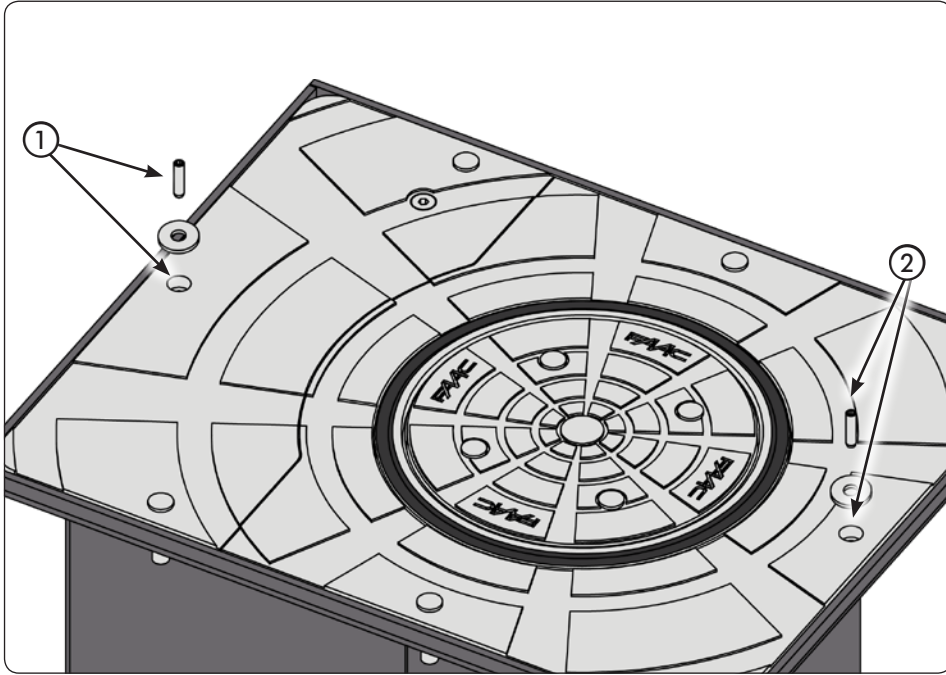

Fig. 4



Place the two included grub screws on the threaded holes indicated in the following reference, then tighten the two eyebolts and use them to lift and position the frame.



Place the bollard taking care to position it plumb. The top level of the frame must be approx. 10 mm higher than the floor surface (to limit the inlet of rainwater in the pit).

To reduce any stumble risk, level the pit to the street surface.

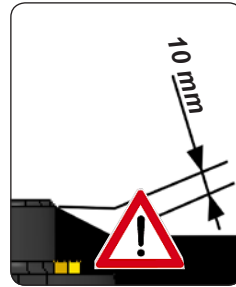

Respect the direction of transit as shown in fig.5.

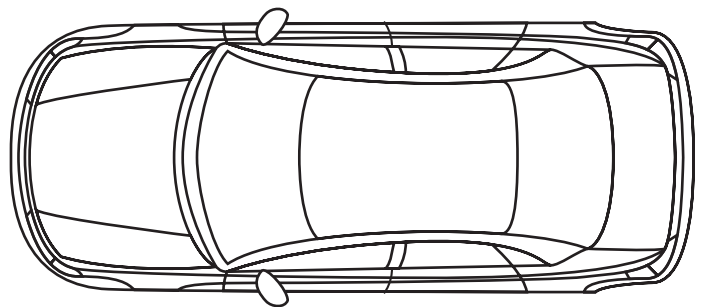
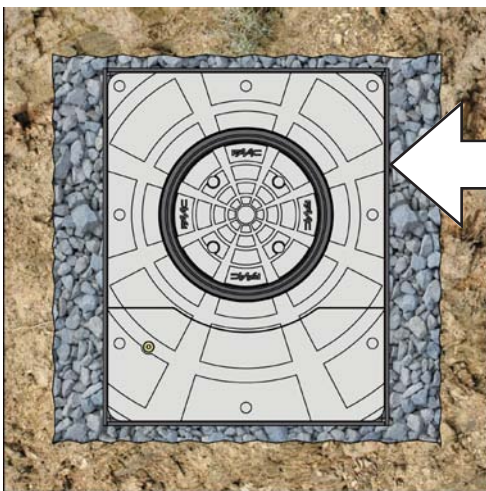

Fig. 5



With the bollard in place, enter additional 35mm of gravel, then lay a flexible sheat (external diameter = 40mm) from the bollard to the control unit.

Dimensions in mm

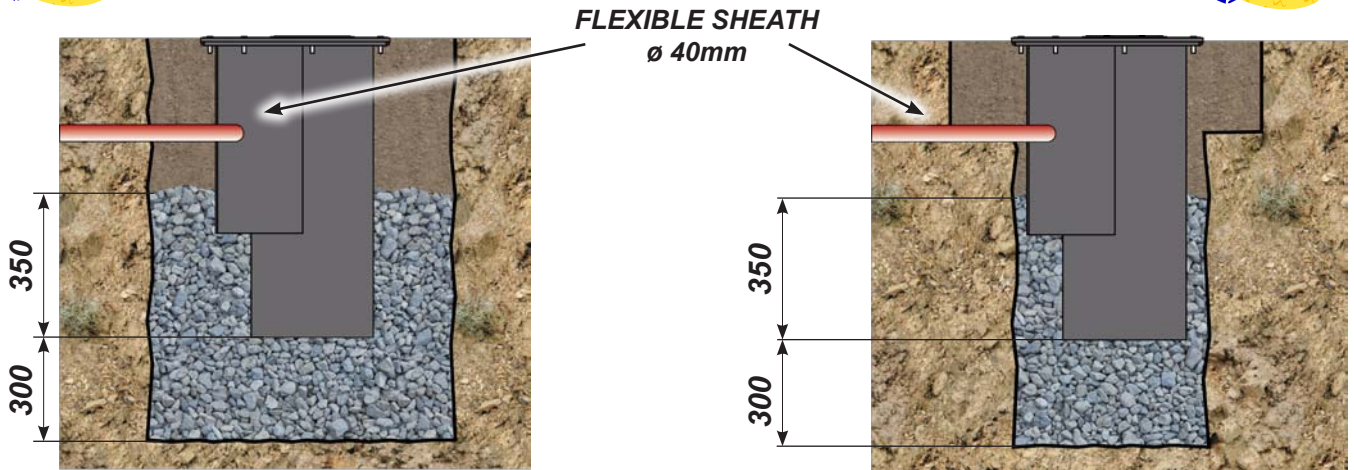

Fig. 6

! Cast concrete, type RCK25, all around the pit to secure it firmly up to about 10cm from the floor surface. After having secured the pit, finish the street surface using the same type of material.

Dimensions in mm

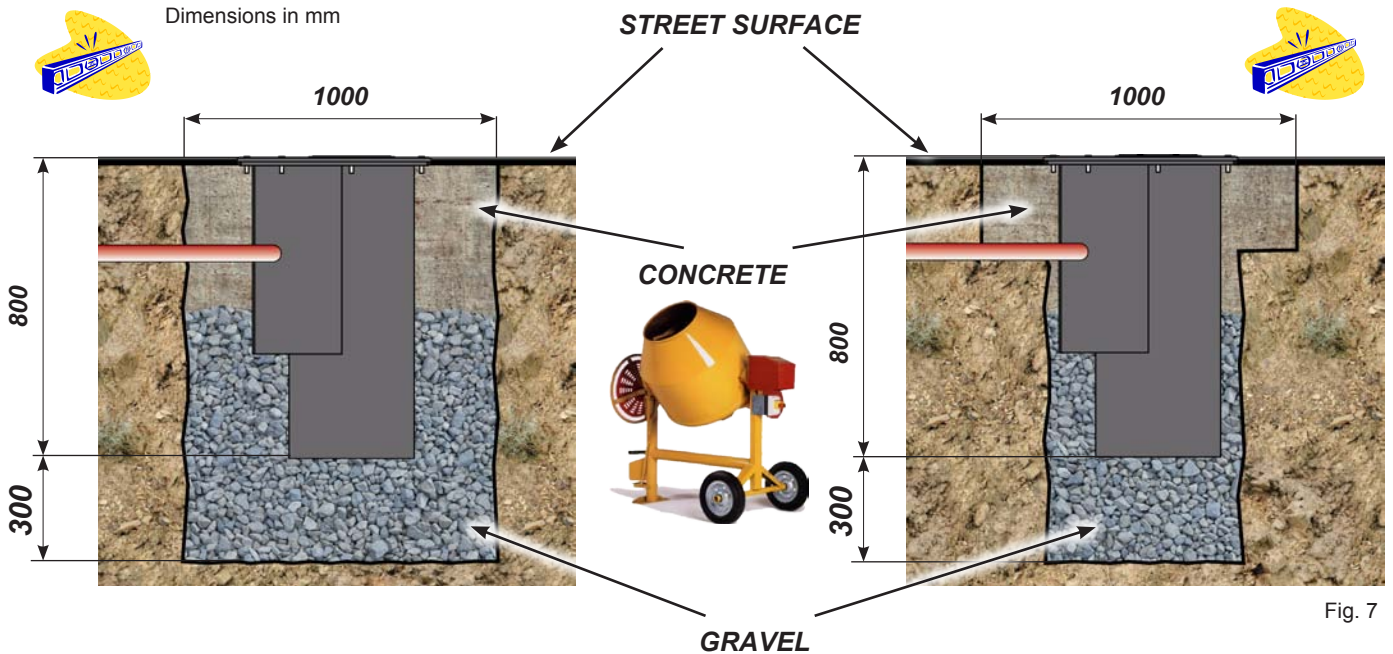

Fig. 7

! Lay the pipelines that are necessary for the connection between the control unit and any additional device (i.e. traffic lights – inductive loops – card reader – etc.) and every other bollards, if any. Prepare the electrical connection and the earthing.

! To connect the bollard to the control board, use a cable, type FG7OR-0.6/1kV-16G1.5, having a max. length of 50 m.

N.B.: every pipe must be laid in compliance with the current rules.

! At the end, remove the protective film from the upper plates.

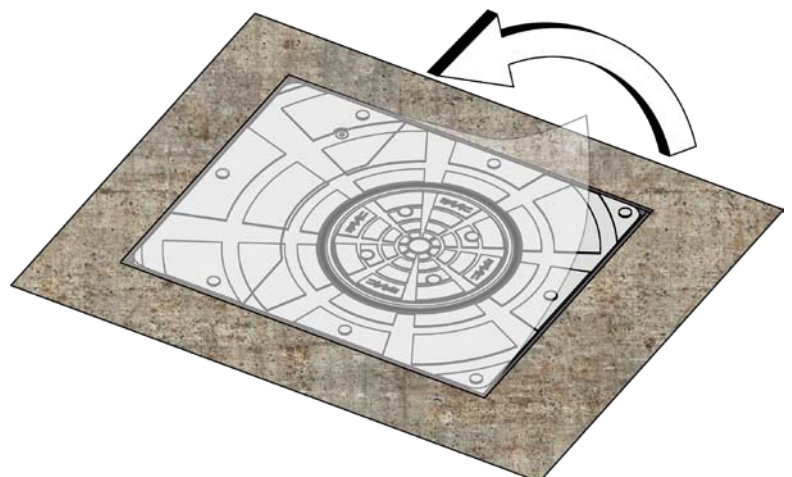

5 ELECTRIC WIRING

For the connection of the bollard to the control unit, use a multi-pole cable, type **FG7OR-0.6/ kV- 6G 1.5 (16 cables of 1.5mm²)** with **max. length of 50 m**. This cable must be laid inside a sheath \varnothing 40mm.

Perform the electric wiring in the junction box on the bollard side, as shown in the figure below. For easier wiring, the junction box can be removed.

! Any additional accessory (i.e. photocells, opening/closing push-buttons, etc.), that have to be connected to the control unit, must compulsorily have double insulation.

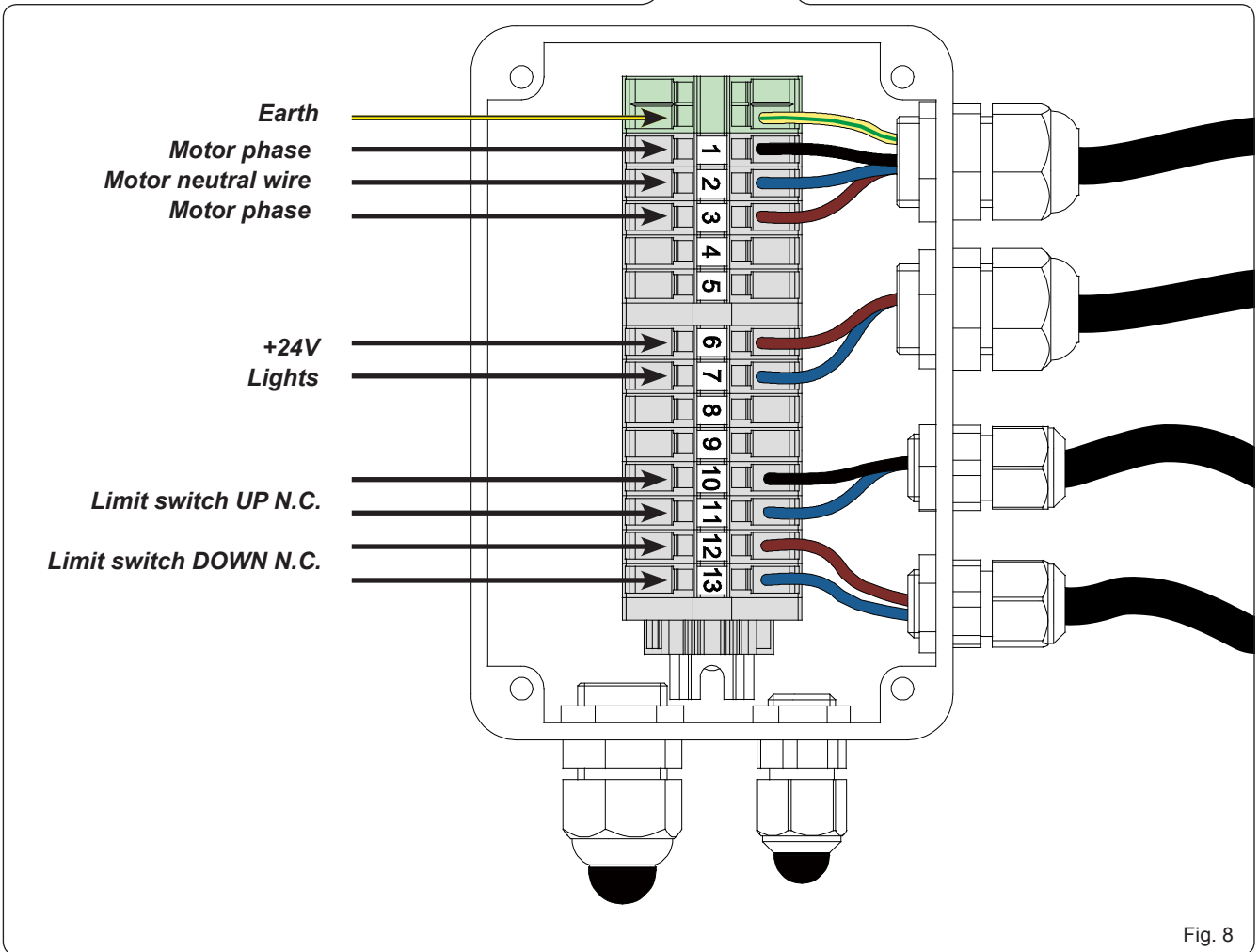
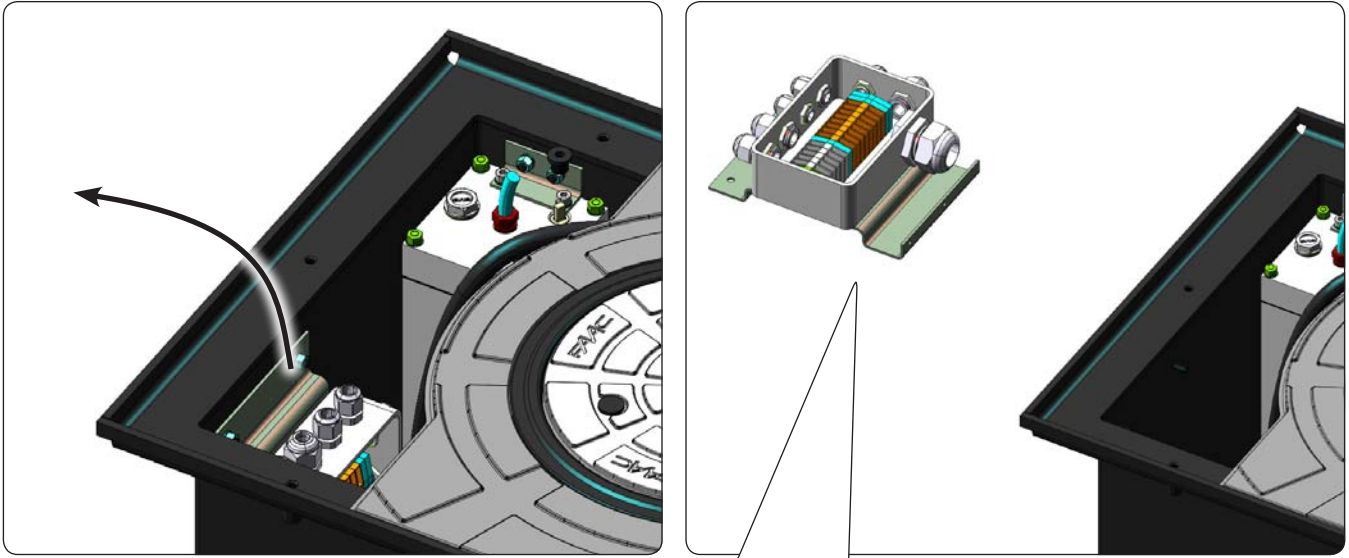

Fig. 8

6 MANUAL OPERATION

To lower the bollard by hand, you need to act on the release device.

1. Loosen the closing screw located on the bollard head (fig. 9 ref. ①).
2. Introduce the supplied key into the relevant hole.
3. Turn counter-clockwise to lower the bollard (fig. 9 ref. ②).

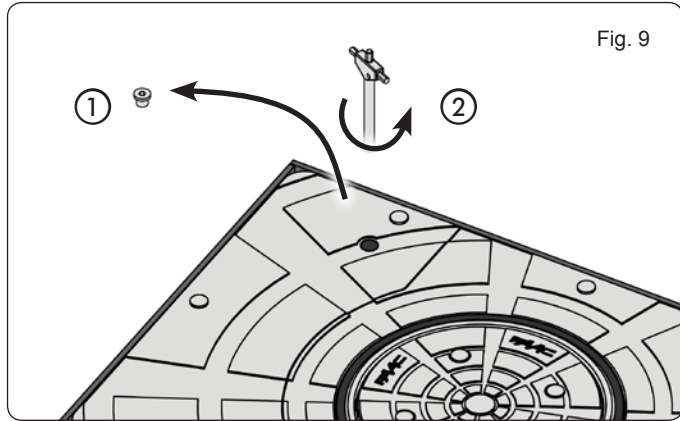

Fig. 9

7 AUTOMATIC OPERATION

To restore the automatic operation:

1. Introduce the supplied key into the relevant hole.
2. Turn clockwise till end of stroke (fig. 10 ref. ①).
3. Tighten again the closing screw on the bollard head (fig. 10 ref. ②).

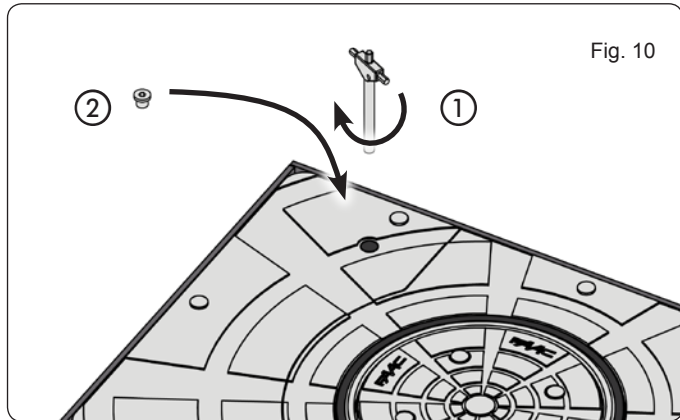

Fig. 10

8 STANDARD PROCEDURE FOR A 6-MONTHLY VERIFY

Ordinary maintenance standard procedure:

1. Clean the pit and remove any settled material by suction
2. Clean the water drainage systems on the pit bottom
3. Check (and repair, if necessary) any oil leakages from the driving piston
4. Check the correct tightening of the bollard screws
5. Clean the driven cylinder and touch up paint, if necessary
6. Check the hydraulic unit and top up oil, if necessary. Check the setting of the operating pressure
7. Check and set, if installed, the functions of the safety pressure switch (40 Kg.)

We advise to perform the above mentioned operation at least every six months.

JE275 CONTROL UNIT



- Always cut the power supply before performing any intervention on the control unit (connections, maintenance).
- Install a differential thermal-magnetic switch with suitable threshold (0.03A) upstream of the system.
- Connect the earth cable to the relevant terminal on the connector J9 of the unit (see figure below).
- Check if the power disconnecting switch is provided with locking key except if it's installed under operator/maintenance man control.
- The control unit installation must be done between 0,4 m and 2,0 m height

9 ELECTRICAL CONNECTIONS

JE275 BOARD SIDE

BOLLARD SIDE

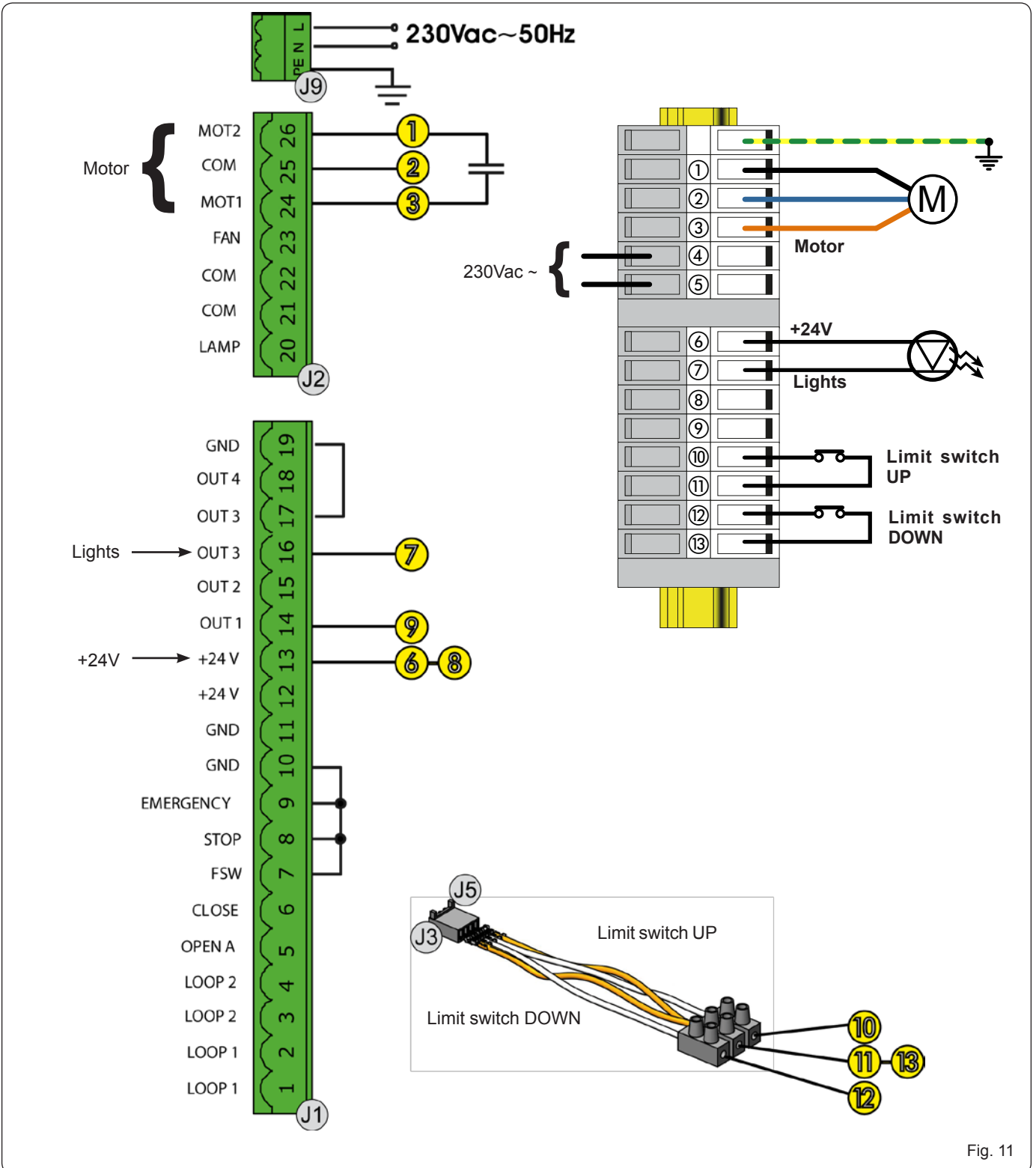
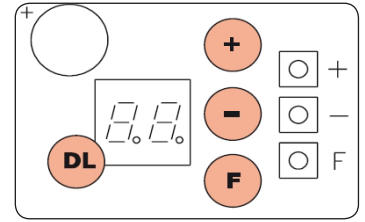

Fig. 11

10 PRE-SETTING SELECTION

After having connected the board and after having supplied it with power according to the previous paragraph, you must select the work pre-setting for the bollard J200HA following the operations below:

1. Enter the 1st level programming, holding down key **F** on the board. The initials **dF** will appear on the display.
2. Release key **F** and select **07** with the key **+**
3. Simultaneously press keys **F** and **-** to exit programming and save the changes performed.



For any further information on the unit programming, please refer to the relevant instructions.

11 POSITIONING THE LOOPS

Below you will find some examples for the realization of magnetic loops with one or more bollards:

1. Installation of a single bollard and two magnetic loops to detect vehicle transit.
2. Installation of a single bollard and of a magnetic loop to protect the perimeter.
3. Installation of four bollards (on a single JE275) and four loops to protect large passages
4. Installation of eight bollards (4 on JE275 MASTER board + 4 on JE275 SLAVE board, see par. 12.2) and eight loops to protect large passages

The loops must be realized according to the instructions provided for the magnetic detector (control unit); they must be connected each other in series or you can use more magnetic detectors and connect the relevant relay contacts in series.

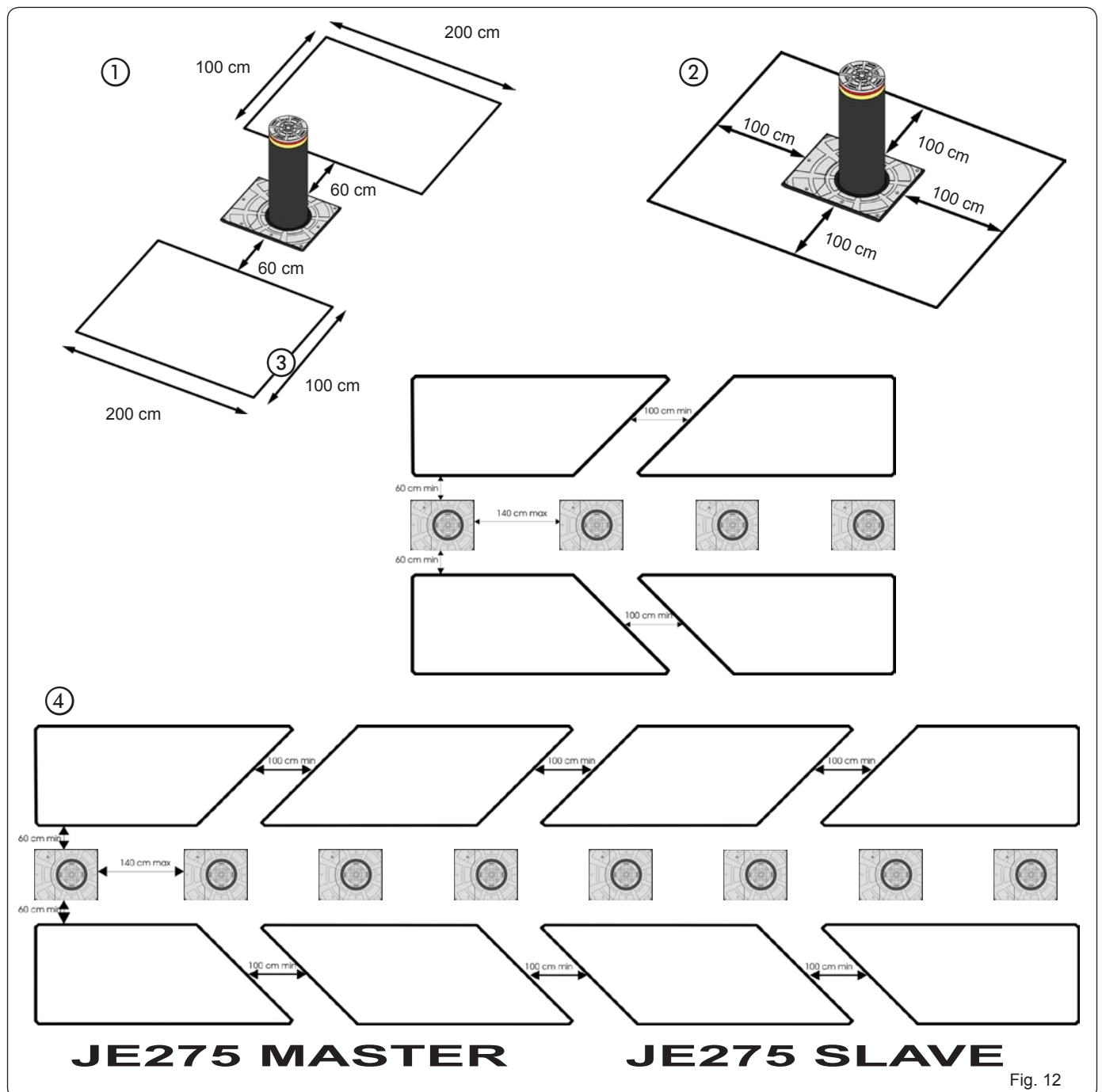

Fig. 12

12 CONNECTING MORE BOLLARDS

12.1 CONNECTION OF UP TO 4 BOLLARDS ON A SINGLE BOARD

Up to 4 bollards can be connected to the same unit and operate simultaneously. Follow the instructions below for a correct wiring and operation (par. 12.3).

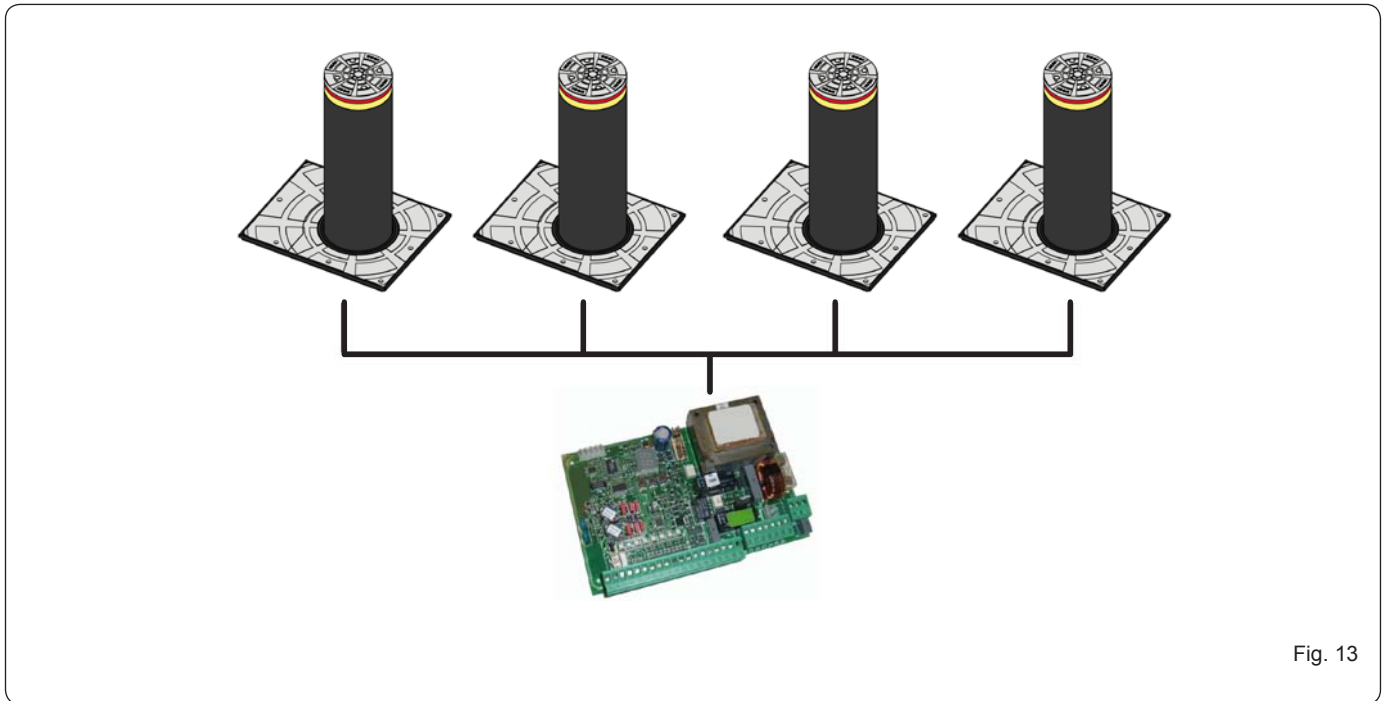

Fig. 13

12.2 CONNECTION OF UP TO 8 BOLLARDS ON TWO JE275 MASTER – SLAVE CONNECTION

You can connect 2 JE275 units in a MASTER-SLAVE configuration for the simultaneous control of 8 bollards. Follow the instructions below for a correct wiring and operation (par.12.4).

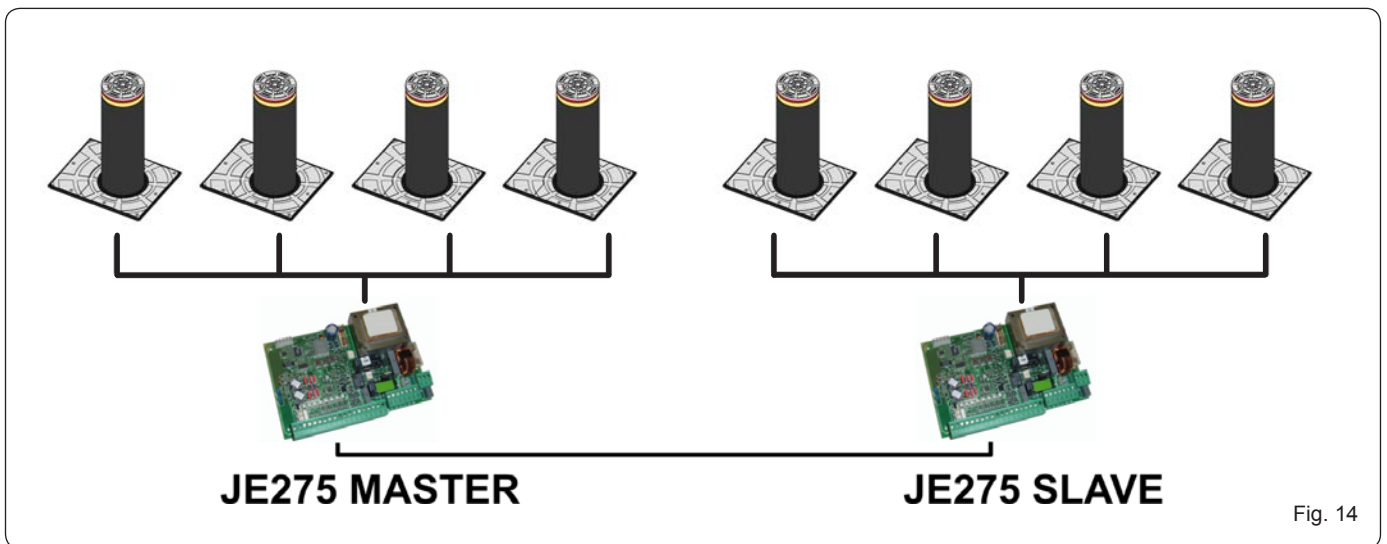

Fig. 14

ENGLISH
Translation of the original instructions

12.3 WIRING OF UP TO 4 BOLLARDS ON A SINGLE BOARD

Connection of 4 motors

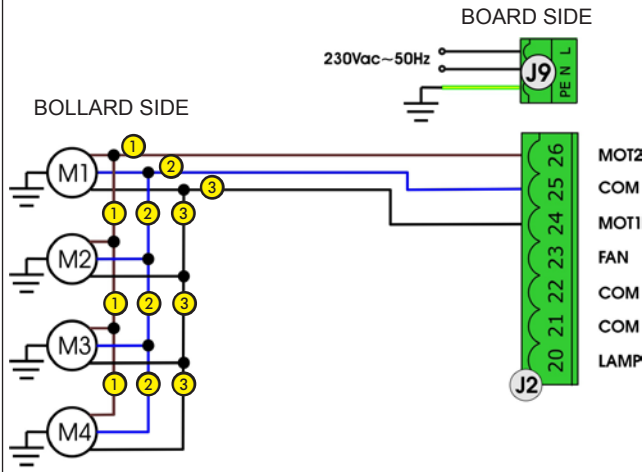

Fig. 15

Connection of lights / buzzer

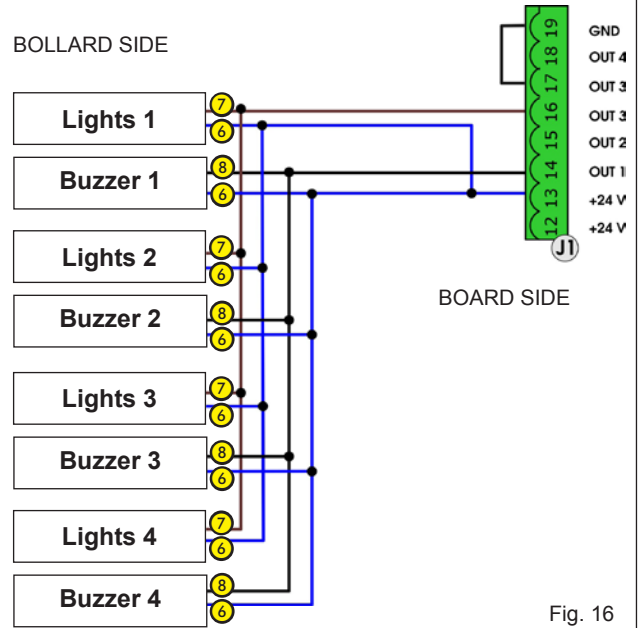

Fig. 16

Connection of 4 limit switches DOWN in parallel. The bollards stop when all 4 limit switches are engaged

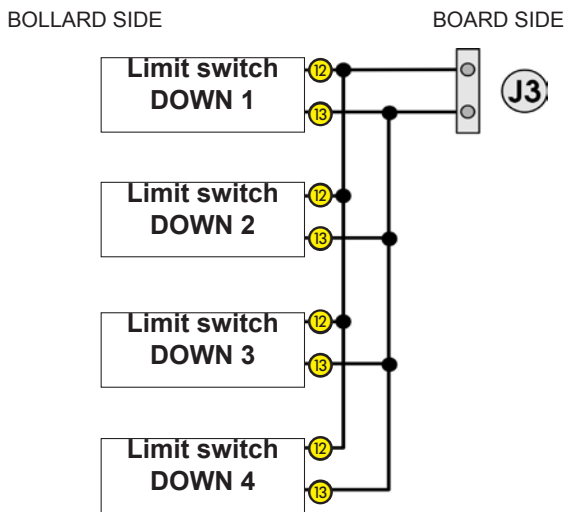

Fig. 17

Connection of 4 limit switches UP in parallel. The bollards stop when all 4 limit switches are engaged

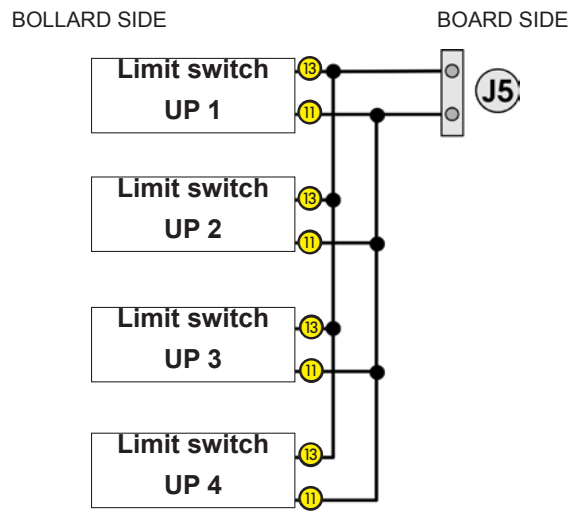

Fig. 18

Connection of 4 pressure switches in series. The first operation of a pressure switch causes the reversal of all bollards

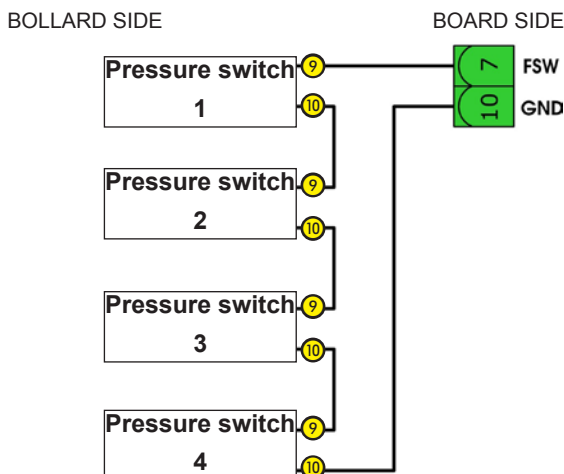
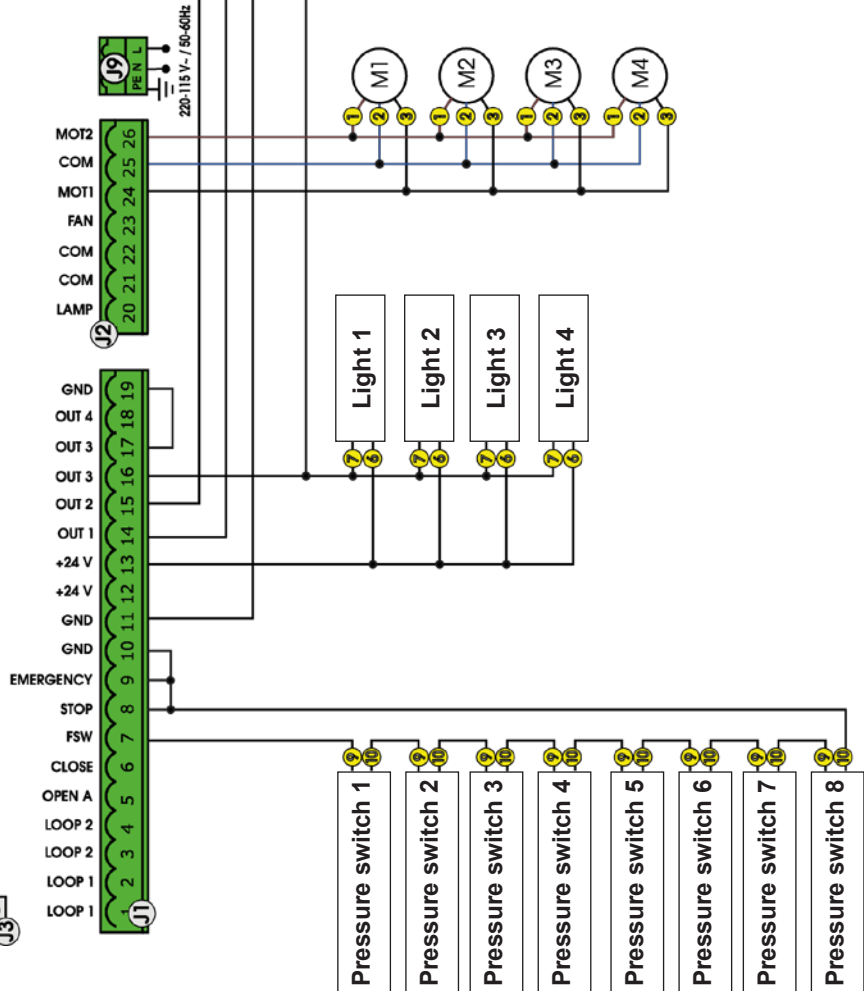
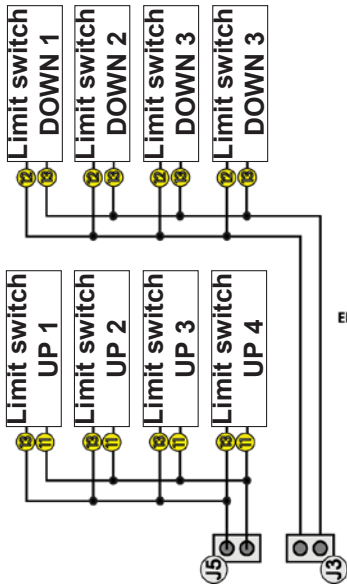

Fig. 19

12.4 WIRING OF UP TO 8 BOLLARDS ON TWO JE275 IN MASTER - SLAVE CONNECTION

JE275 MASTER

1. Default 07
2. o1=11 p1=no
3. o2=12 p2=no



JE275 SLAVE

1. Default 07
2. Log=C
3. 3° liv. par 03=y
4. log=Cu
5. 2° liv. o3=15 p3=no

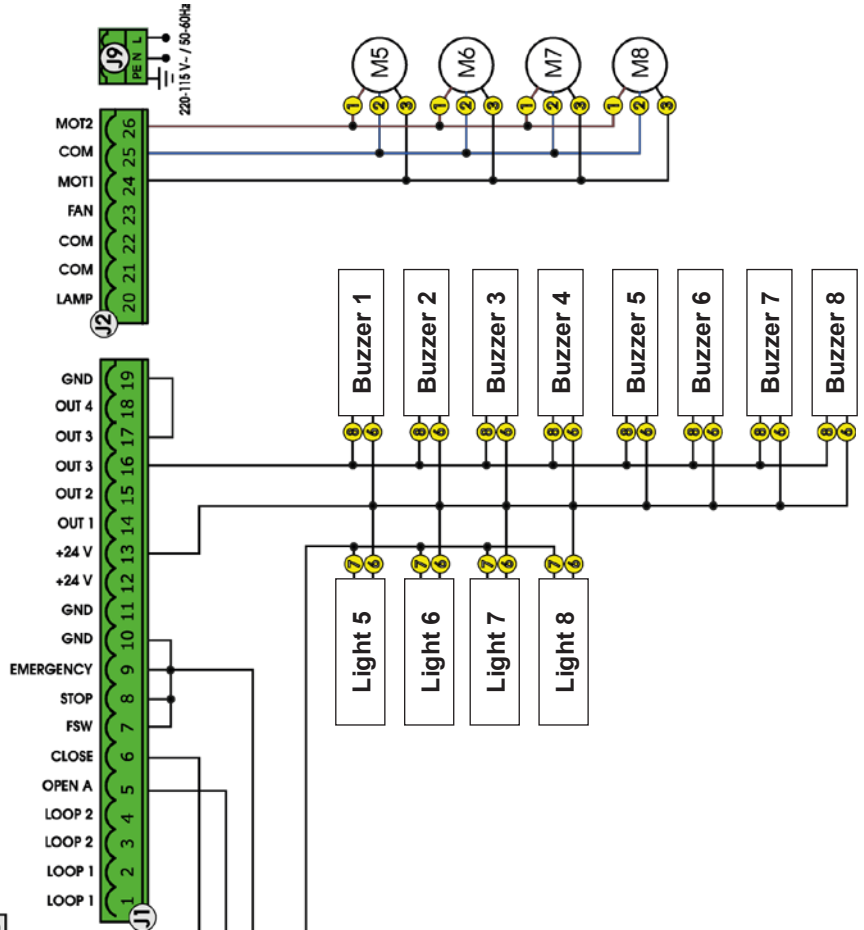
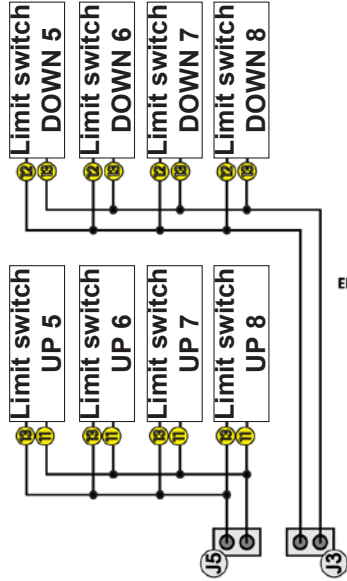

Fig. 20

13 TROUBLESHOOTING

The indications below will help you locate and solve particular conditions.

	CONDITION	ADVICE
1	The bollard rises for a few centimetres and then lowers immediately	<ul style="list-style-type: none"> • Make sure you have selected the default no. 7 on the JE275 board • Check if the safety pressure switch wiring was performed correctly, (optional, see the related instructions) • Make sure that the LED DL3 (FSW) on the JE275 board remains ON for the whole movement • Adjust the pressure switch (if installed) • Replace the pressure switch
2	As soon as the bollard reaches the position, it reverses immediately	<ul style="list-style-type: none"> • Check if the wiring of the limit stops was performed correctly, see fig. 11 or fig. 18 • Make sure that the up position limit stops are correctly positioned, see ref. 11 fig.1
3	The bollard does not rise, it remains down.	<ul style="list-style-type: none"> • Make sure you have selected the default no. 7 on the JE275 board • Check if the wiring of the solenoid valve was performed correctly, (optional, see the related instructions) • Check if the solenoid valve was adjusted correctly • Replace the solenoid valve • Make sure the bollard is hydraulically locked, see par. 7
4	The bollard remains up in closed position.	<ul style="list-style-type: none"> • Make sure nothing between the cylinder and the sliding bush prevents the bollard movement; try and shake the cylinder to facilitate its downstroke
5	The buzzer and the LED flashing lamp do not operate	<ul style="list-style-type: none"> • Make sure you have selected the default no. 7 on the JE275 board • Check if the power connector under the head was fitted correctly

14 CLEANING / UNMOUNTING PROCEDURE

In case you need to unmount / clean the bollard, proceed as follows. Each step (to be followed in sequence) allows for the access to a different part of the bollard:

- 1) Top limit switch replacement
- 2) Headlight replacement
- 3) Cylinder removal for internal cleaning.
- 4) Piston removal and access to lower limit switch

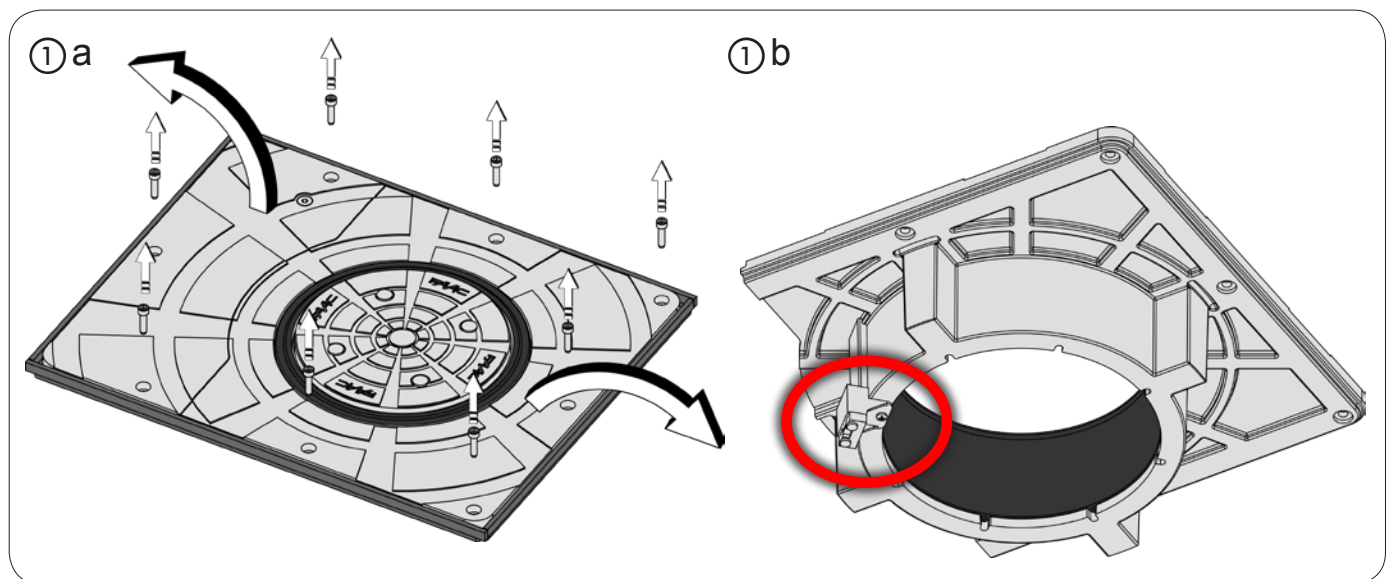

② a

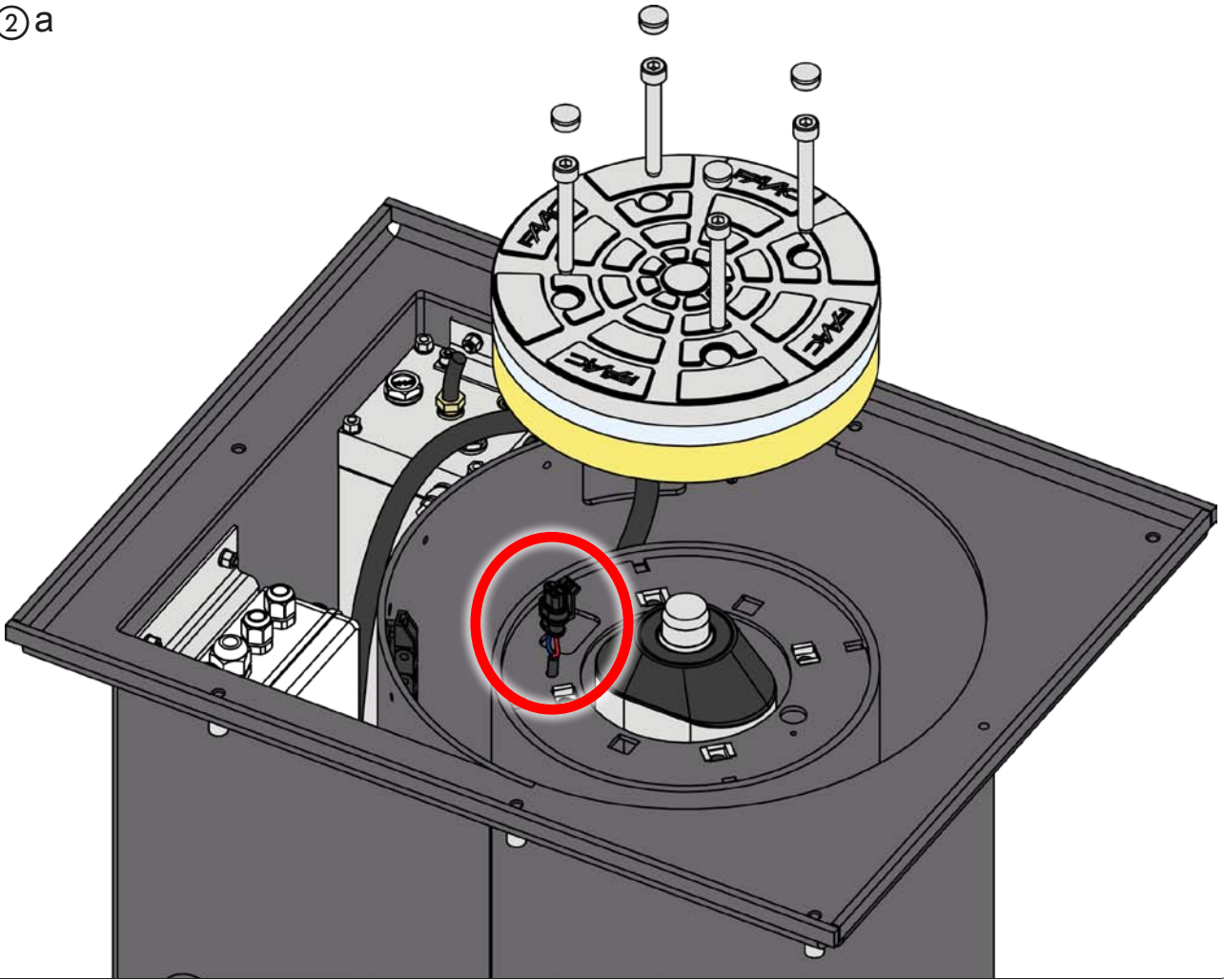

② b

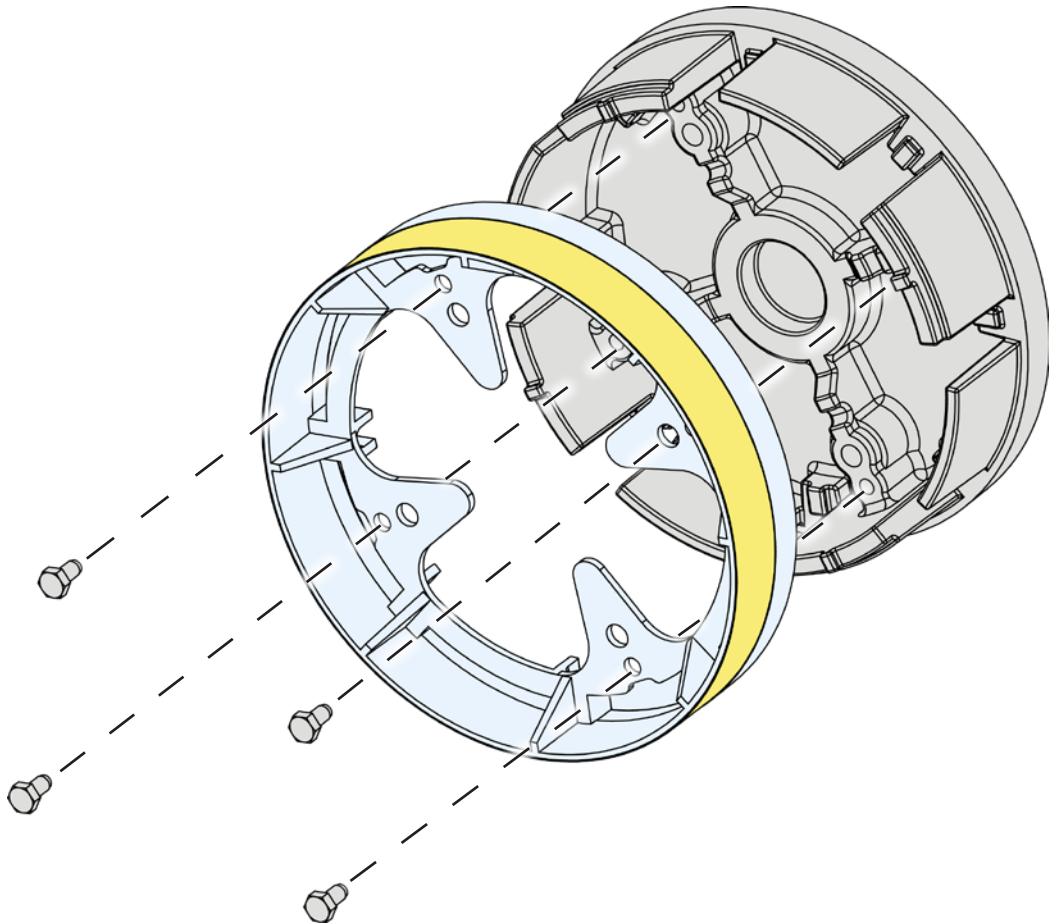

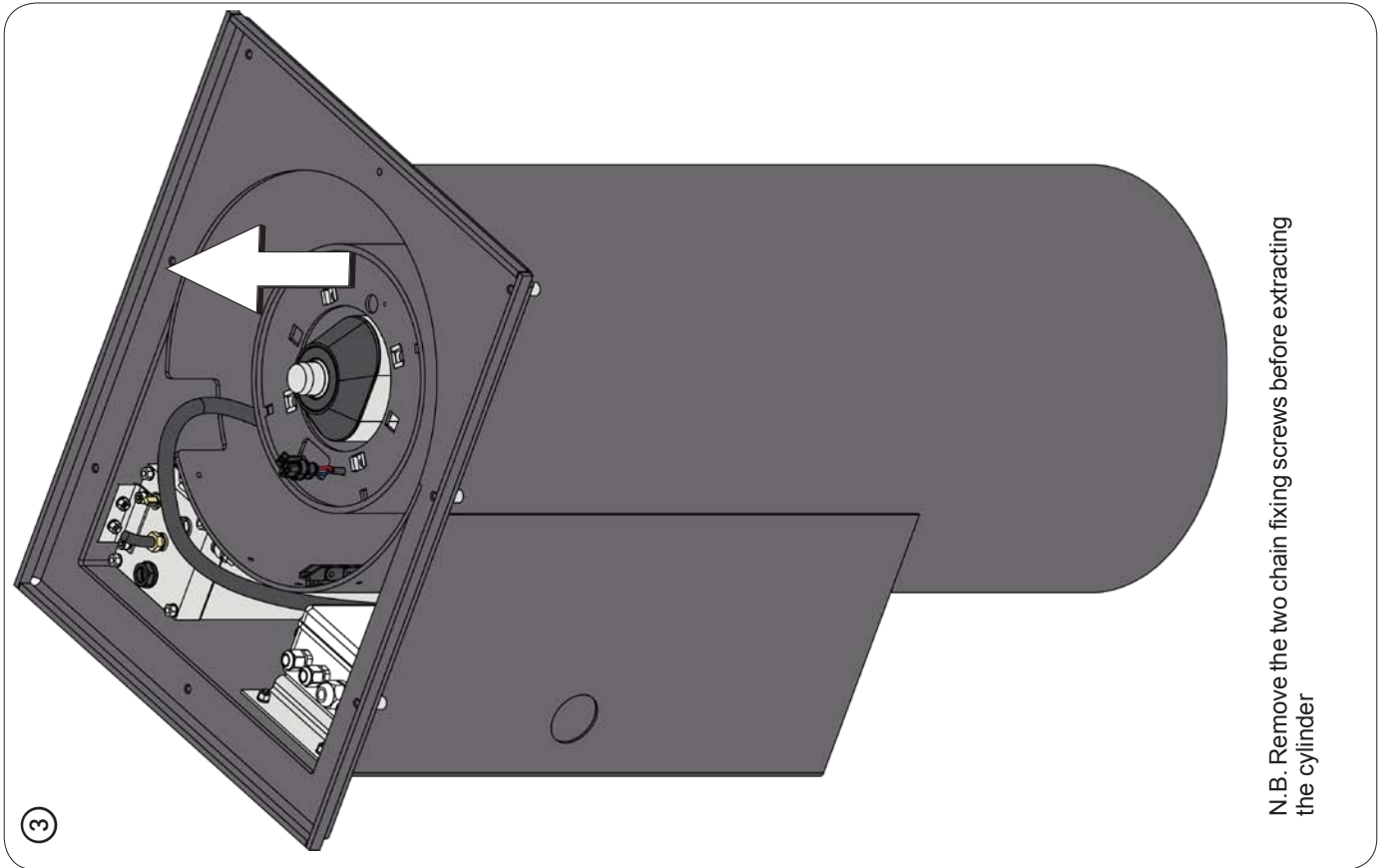

N.B. Remove the two chain fixing screws before extracting the cylinder

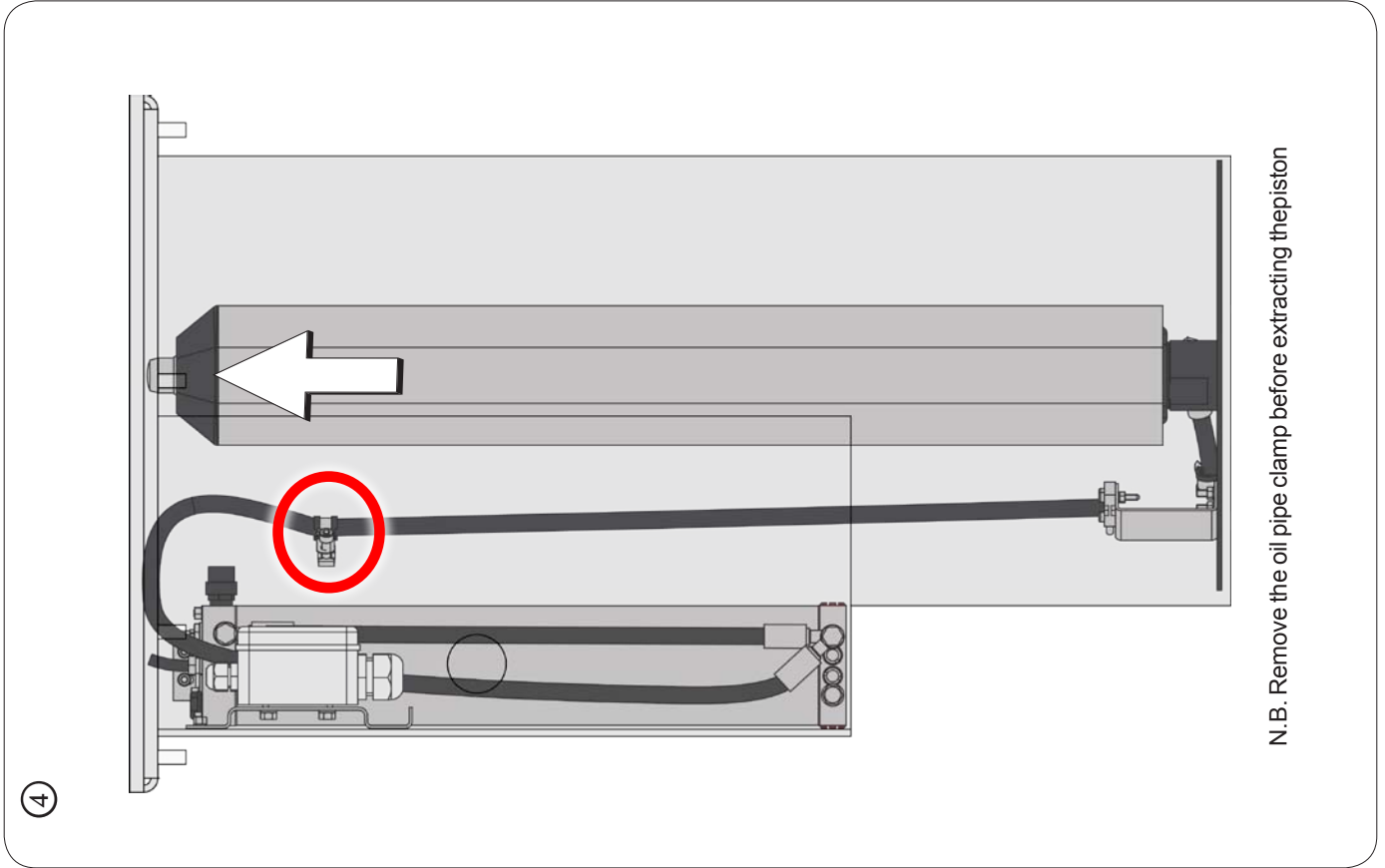

N.B. Remove the oil pipe clamp before extracting the piston