

J355HA M30-P1

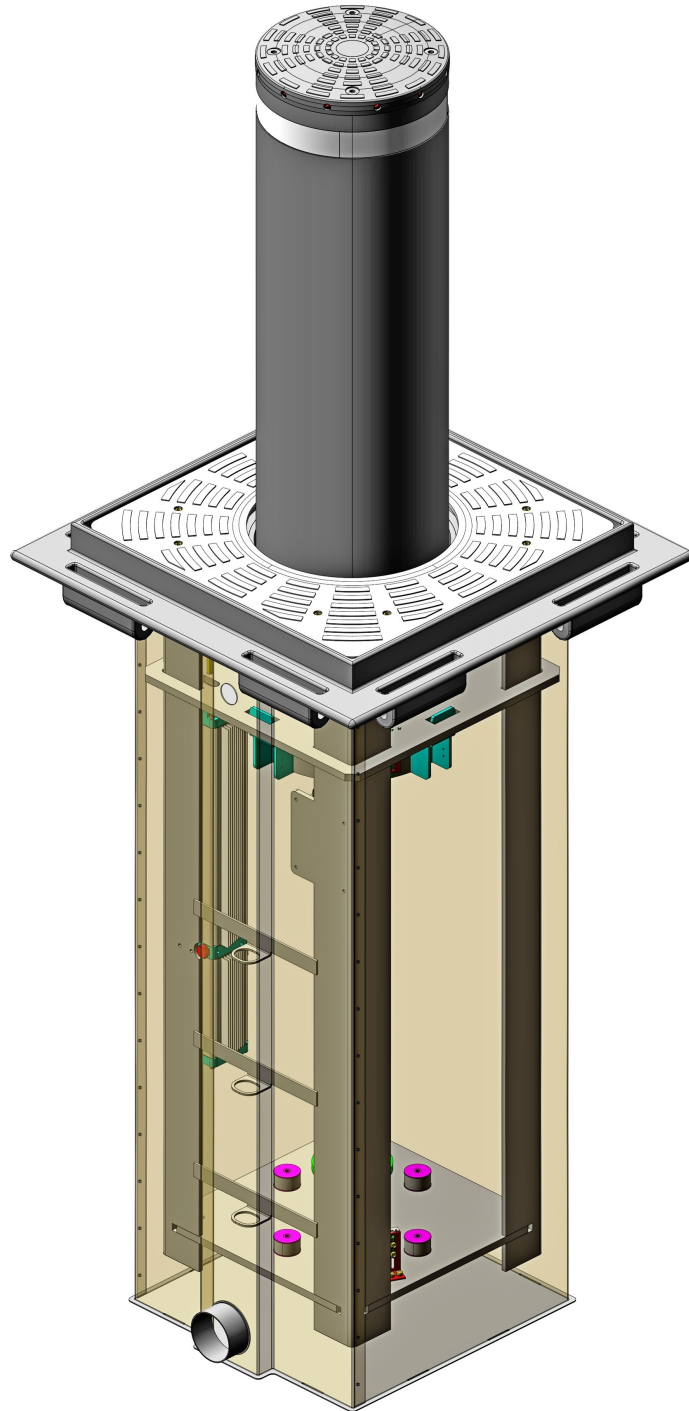

CE DECLARATION OF CONFORMITY FOR MACHINES

(DIRECTIVE 2006/42/EC)

Manufacturer: FAAC S.p.A.

Address: Via Calari, 10 - 40069 Zola Predosa BOLOGNA - ITALY

Declares that: The operator mod. J355HA M30-P1

is built to be integrated into a machine or to be assembled with other machinery to create a machine under the provisions of Directive 2006/42/EC

conforms to the essential safety requirements of the following EEC directives

2006/95/EC Low Voltage Directive

2004/108/EC Electromagnetic Compatibility Directive

and also declares that it is prohibited to put into service the machinery until the machine in which it will be integrated or of which it will become a component has been identified and declared as conforming to the conditions of Directive 2006/42/EEC and subsequent amendments.

Bologna, 01st January 2013

The Managing Director

A. Marcellan



ENGLISH

WARNINGS FOR THE INSTALLER

GENERAL SAFETY OBLIGATIONS

1. ATTENTION! To ensure the safety of people, it is important that you read all the following instructions. Incorrect installation or incorrect use of the product could cause serious harm to people.
2. Carefully read the instructions before beginning to install the product.
3. Do not leave packing materials (plastic, polystyrene, etc.) within reach of children as such materials are potential sources of danger.
4. Store these instructions for future reference.
5. This product was designed and built strictly for the use indicated in this documentation. Any other use, not expressly indicated here, could compromise the good condition/operation of the product and/or be a source of danger.
6. FAAC declines all liability caused by improper use or use other than that for which the automated system was intended.
7. Do not install the equipment in an explosive atmosphere: the presence of inflammable gas or fumes is a serious danger to safety.
8. FAAC is not responsible for failure to observe Good Technique in the construction of the closing elements to be motorised, or for any deformation that may occur during use.
9. Installation must be performed in compliance with current Standards.
10. Before attempting any job on the system, cut out electrical power.
11. The mains power supply of the automated system must be fitted with an all-pole switch with contact opening distance of 3 mm or greater. Use of a 6A thermal breaker with all-pole circuit break is recommended.
12. Make sure that a differential switch with threshold of 0.03 A is fitted upstream of the system.
13. Make sure that the earthing system is perfectly constructed and connect metal parts of the closure to it.
14. The automated system is supplied with an intrinsic anti-crushing safety device consisting of a torque control. Nevertheless, its tripping threshold must be checked as specified in the Standards indicated at point 10.
15. The safety devices (EN 12978 standard) protect any danger areas against mechanical movement Risks, such as crushing, dragging, and shearing.
16. Use of at least one indicator-light (i.e. flashing lamp incorporated in the bollard head) is recommended for every system, as well as a warning sign adequately secured.
17. FAAC declines all liability as concerns safety and efficient operation of the automated system, if system components not produced by FAAC are used.
18. For maintenance, strictly use original parts by FAAC.
19. Do not in any way modify the components of the automated system.
20. The installer shall supply the user with the necessary information for the manual operation of the system in the event of emergency.
21. Do not allow children or adults to stay near the product while it is operating.
22. Keep remote controls or other pulse generators away from children, to prevent the automated system from being activated involuntarily.
23. Transit on the bollard is permitted only when the device is completely down.
24. The user must not attempt any kind of repair or direct action whatever and contact qualified personnel only.
25. Anything not expressly specified in these instructions is not permitted.

INDEX

1. GENERAL NOTES.....	2
2. DESCRIPTION AND TECHNICAL SPECIFICATIONS.....	2
3. DIMENSIONS.....	3
4. FACILITIES.....	4
4.1 PREPARING THE FOUNDATION CAGE.....	5
4.2 SECURING THE PIT.....	6
5. ELECTRIC WIRING.....	8
6. INSERTING THE BOLLARD IN THE PIT.....	9
7. FASTENING THE TOP CROWN.....	9
8. MANUAL OPERATION.....	10
9. AUTOMATIC OPERATION.....	10
10. MAINTENANCE.....	10
11. ELECTRICAL CONNECTIONS.....	11
12. PRE-SETTING SELECTION.....	11
13. CONNECTING 2 BOLLARDS TO 2 JE275 BOARDS - MASTER-SLAVE CONNECTION.....	12
14. TROUBLESHOOTING.....	13
15. PERFORMING MAINTENANCE ON THE EFO SYSTEM.....	13

J355HA M30-P1 BOLLARD



Please read with the utmost care this manual supplied with the product, since it contains important indications about safety, installation, use and maintenance.

1. GENERAL NOTES

These instructions apply to model

J355HA M30-P1

This model refers to anti-terrorist automatic hydraulic traffic bollards. The cylinder is driven by a two-motor hydraulic unit fixed inside the structure.

2. DESCRIPTION AND TECHNICAL SPECIFICATIONS

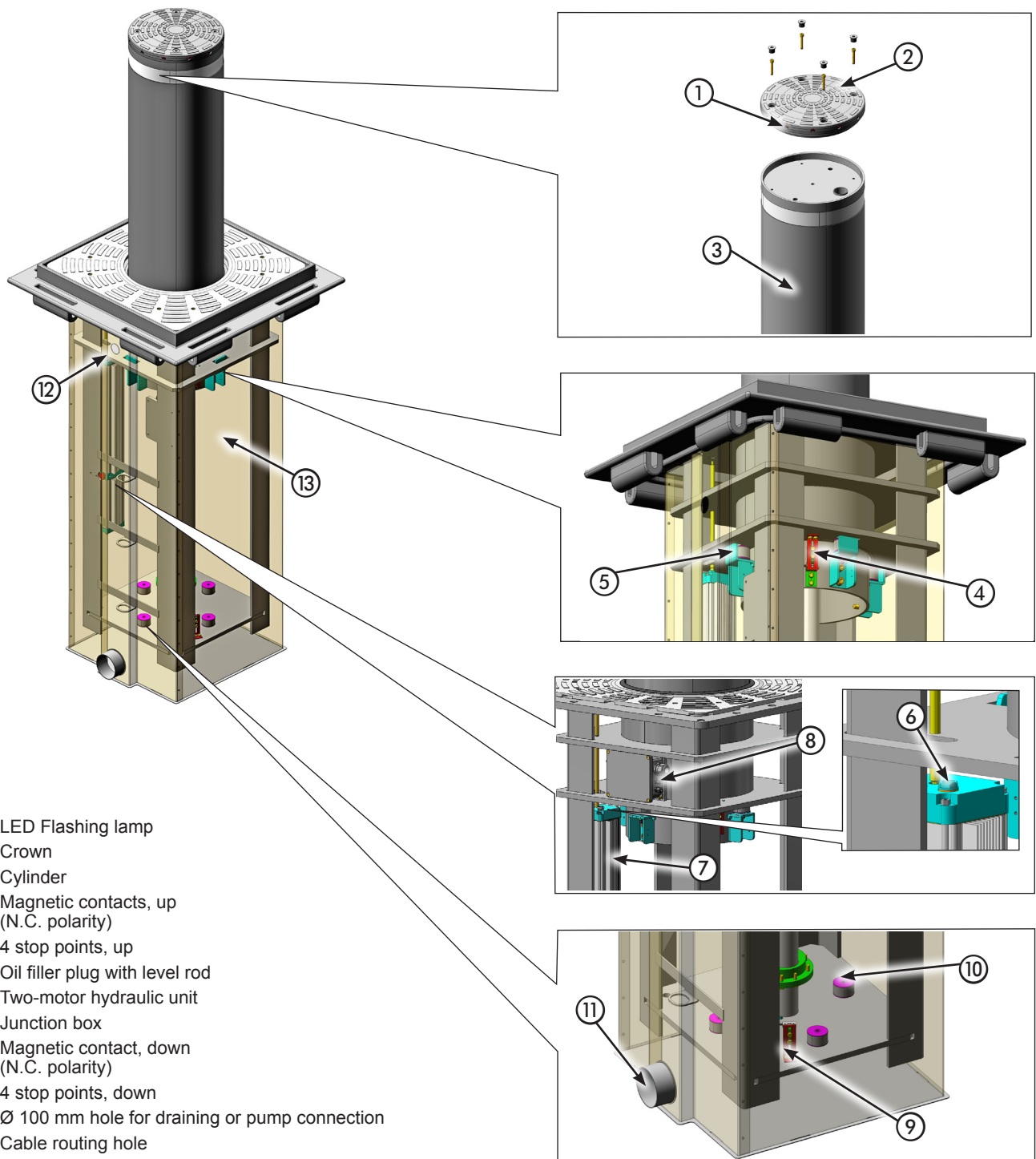



Fig. 1

Tab. A - Technical Specifications

MODEL	J355 M30-P1
Power supply	230 V~ (+6% -10%) 50 (60) Hz
Max. absorbed power (W)	1200
Max. force (N)	5000
Max. pump delivery (lpm)	6
Minimum lifting time (sec)	6
Minimum lifting time (using EFO) (sec)	1,5
Minimum lowering time (sec)	2
Operating ambient temperature (°C)	-15 ÷ +55
Weight bollard and pit (kg)	490 (bollard) 250 (pit)
Oil quantity (l) (1)	3
Protection class	IP66
Overall dimensions	See Fig.2
Capacitor (2)	2 x 20µF - 400V
Burglar-proofing (J) (3)	656000

 (1) check the oil level using the rod attached to the filler plug (Fig. 1 ref. ⑥) with the piston rod completely retracted and pressurised EFO system.



 (2) The two thrust capacitors (20yF - 400v) can be preloaded inside the junction box (see Fig. 13).

 (3) certified under ASTM F2656-07 CLASS M30-P1

3. DIMENSIONS

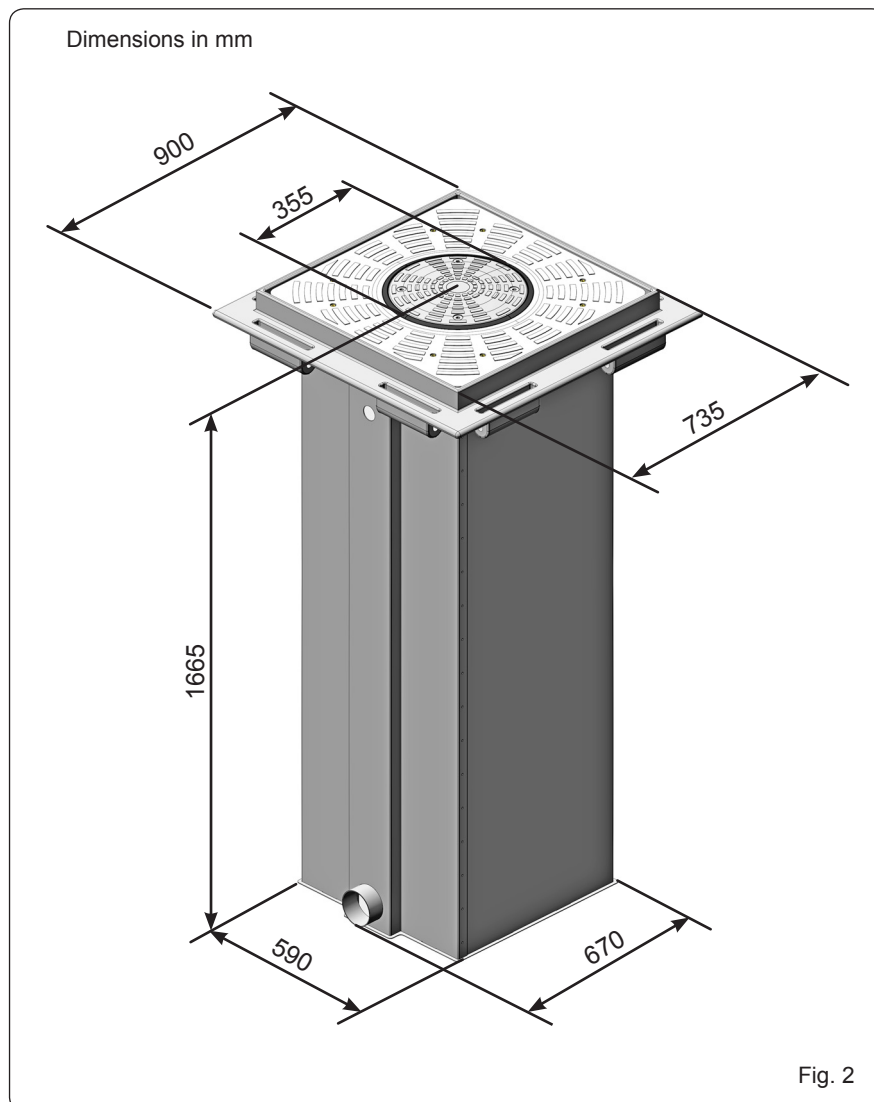

4. FACILITIES

 For draining, use a \varnothing 100 flexible tube.

 Dig up to a depth of about 1.8 m

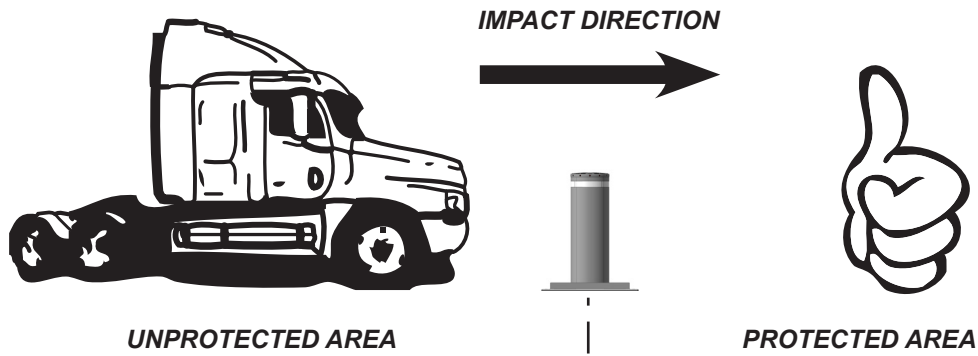

Dimensions in mm

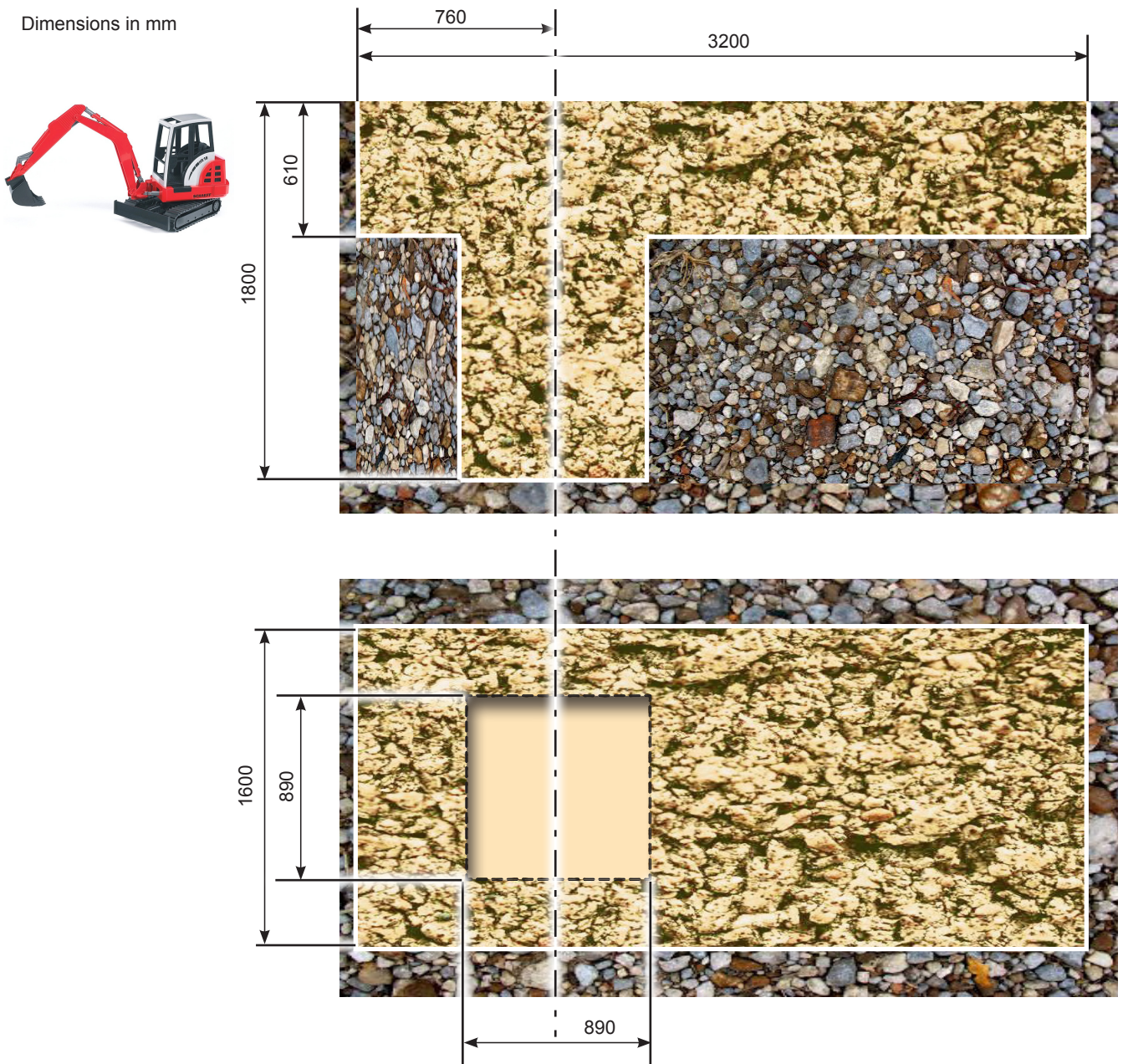

Fig. 3

4.1 PREPARING THE FOUNDATION CAGE

Prepare the foundation cage (not supplied by us) as shown in the figure below using $\varnothing 12$ mm iron rods
CLASS B450C

Dimensions in mm

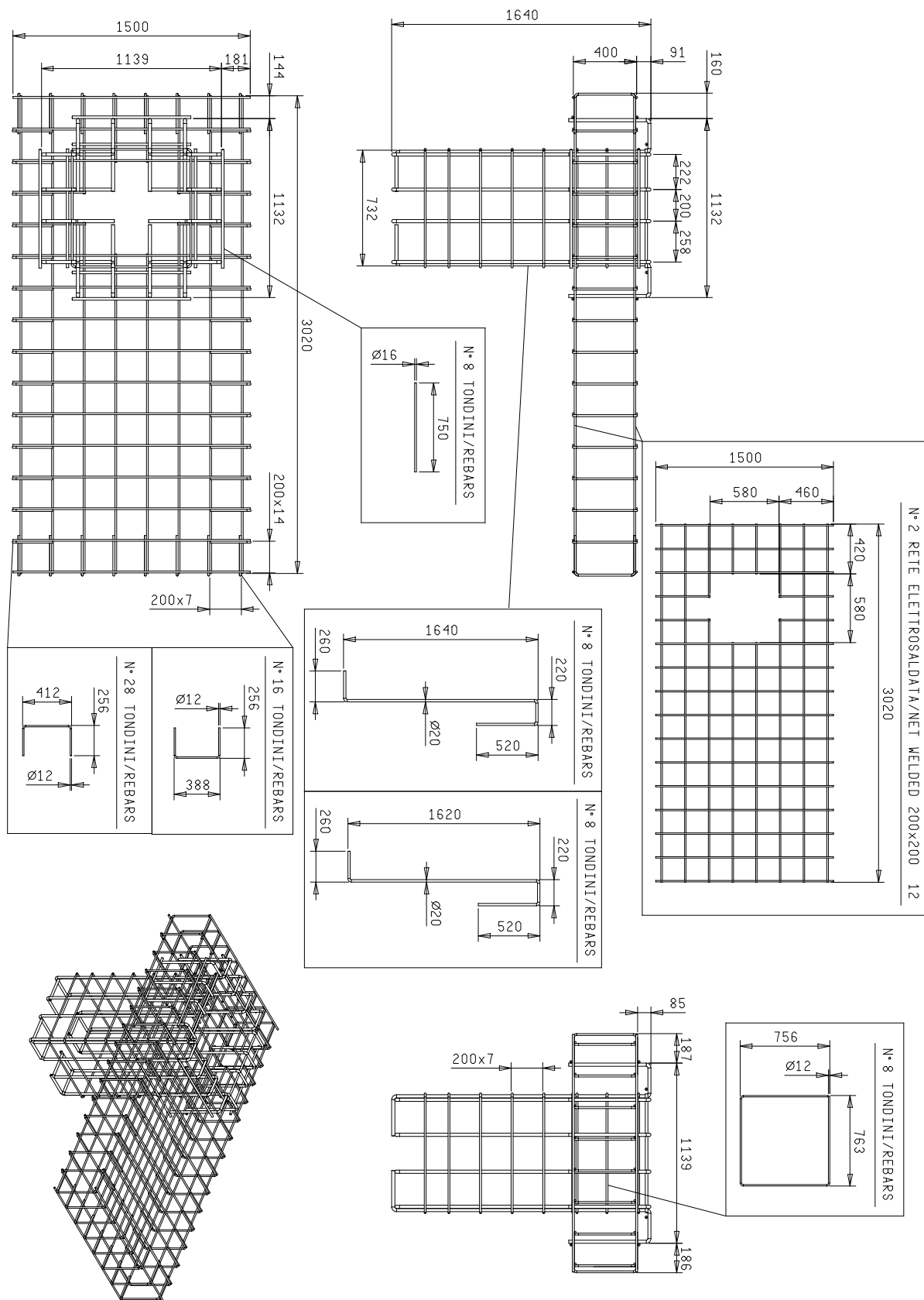

Fig. 4

4.2 SECURING THE PIT

Once the foundation cage is completed, secure the counter-frame to the pit plate using the M10x25 screws, as shown in Fig. 5.

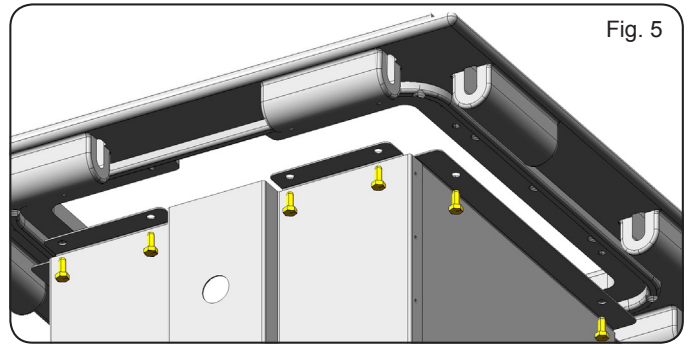
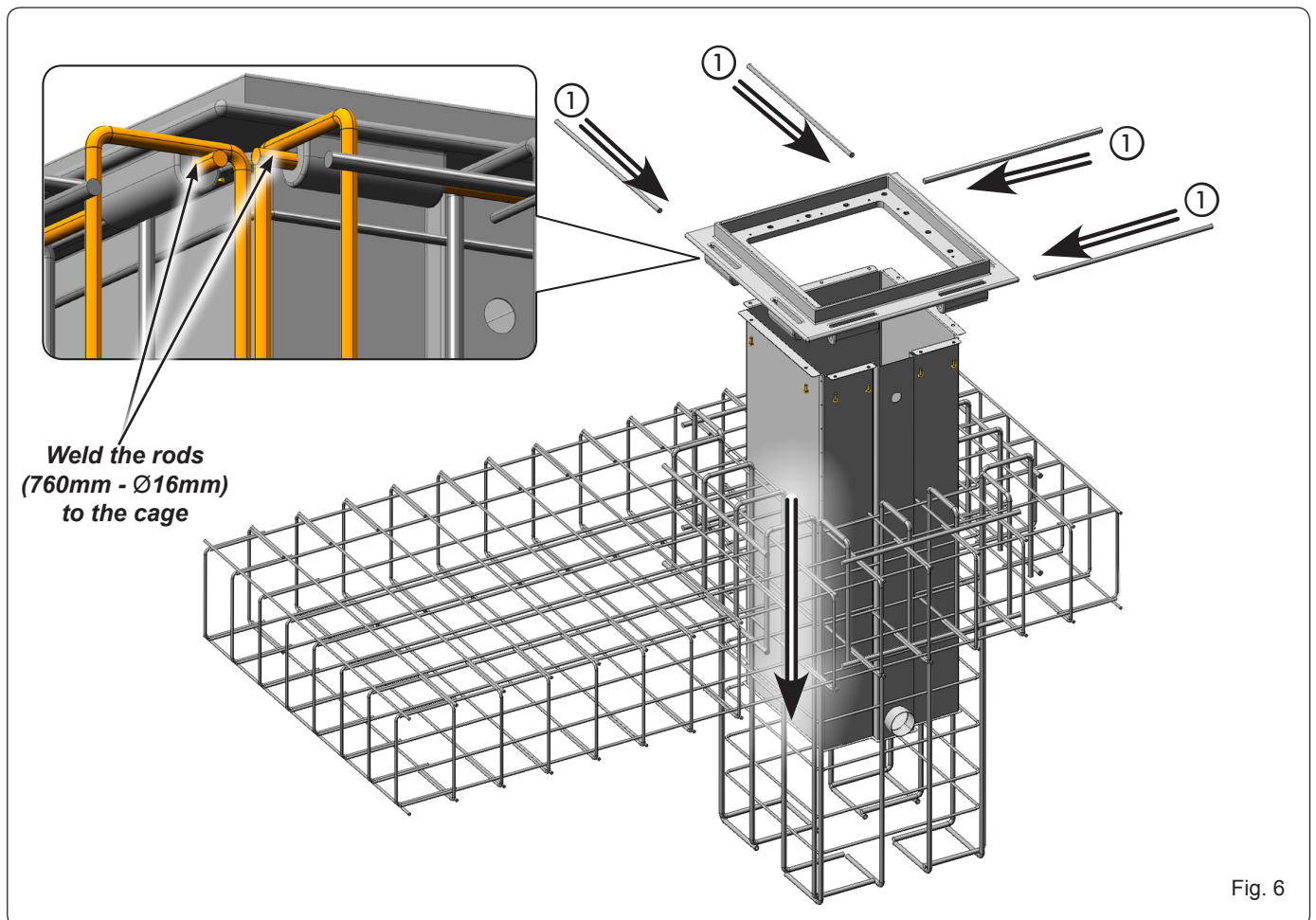

Fig. 5

Then, place the pit in the cage as shown in Fig. 6, and carefully weld the 4 rods 760mm - Ø 16mm (ref. ① in Fig. 6) to the cage



Weld the rods
(760mm - Ø16mm)
to the cage

Fig. 6



Place the thus composed metal cage in the dug-out area, and ensure that it is plumb. The upper level of the counter-frame must be approximately 10 mm higher than the tread, as shown to the right (to limit entry of rainwater in the pit).



After installation of the pit, lay a flexible sheath, internal diameter 45mm, from the connection in the metallic pit to the drive control station (see Fig. 7).



Pour class C25/30 concrete all around the cage to secure it properly, up to approximately 10 cm from the tread area. Wait at least 7 days for the concrete to set correctly and finish the road surface using the same type of material.



Lay the pipelines, that are necessary for the connection between the control unit and any additional device, if any. Prepare the electrical connection and the earthing.



To connect the bollard to the control board, use a cable, type FG7OR-0,6/1kV-16G1,5, having a max. length of 50 m.

N.B.: every pipe must be laid in compliance with the current rules.

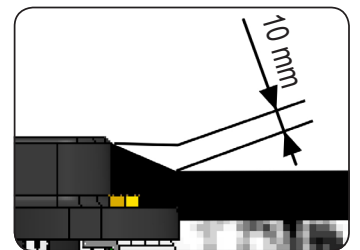

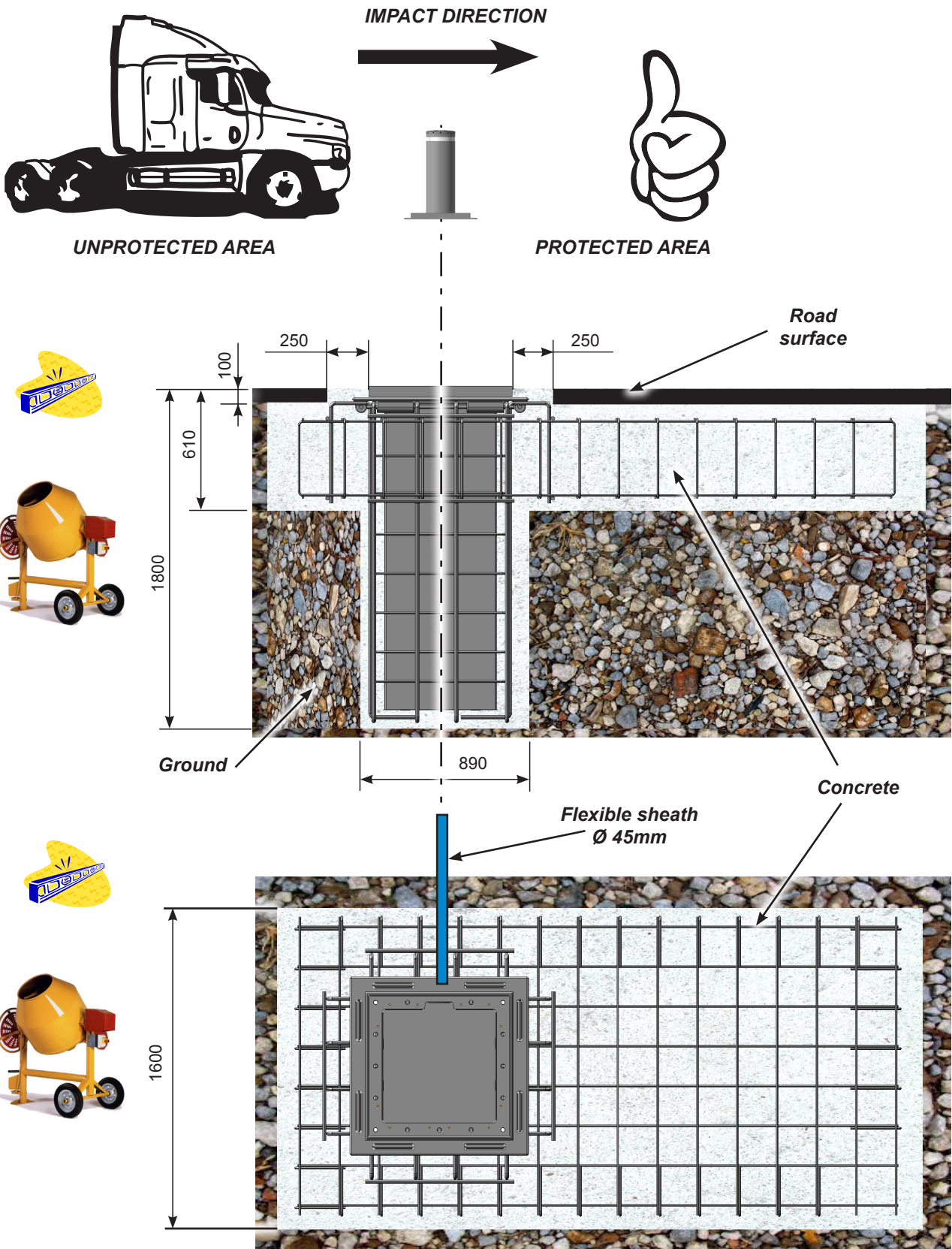

Note:

1. The foundation concrete can be poured directly into the dug-out area.
2. Concrete specifications:
 - A. Class C25/30.
 - B. Concrete with 10-30 aggregate according to UNI EN 12620 standard
 - C. The bollard must be installed after at least 7 days of concrete setting.
3. The compacting index of the surrounding ground must be at least 90% of the "Proctor" optimum curve, according to UNI EN 13286-2:2005 standard.
4. The steel framework must comply with class B450C (ASTM A615 Grade 60).

Dimensions in mm

Fig. 7

5. ELECTRIC WIRING

For the connection of the bollard to the control unit, use a multi-pole cable, type **FG7OR-0.6/ kV- 16G 1.5 (16 cables of 1.5mm²) with max. length of 50 m**. This cable must be laid inside a sheath \varnothing 45mm, secured to the cable clamp in the bottom part of the frame (fig. 8 ref. ①) and must come out of the pit by 2.5 m.

Perform the electric wiring in the junction box on the bollard side, as shown in the figure below.



Any additional accessory (i.e. photocells, opening/closing push-buttons, etc.), that have to be connected to the control unit, must compulsorily have double insulation.

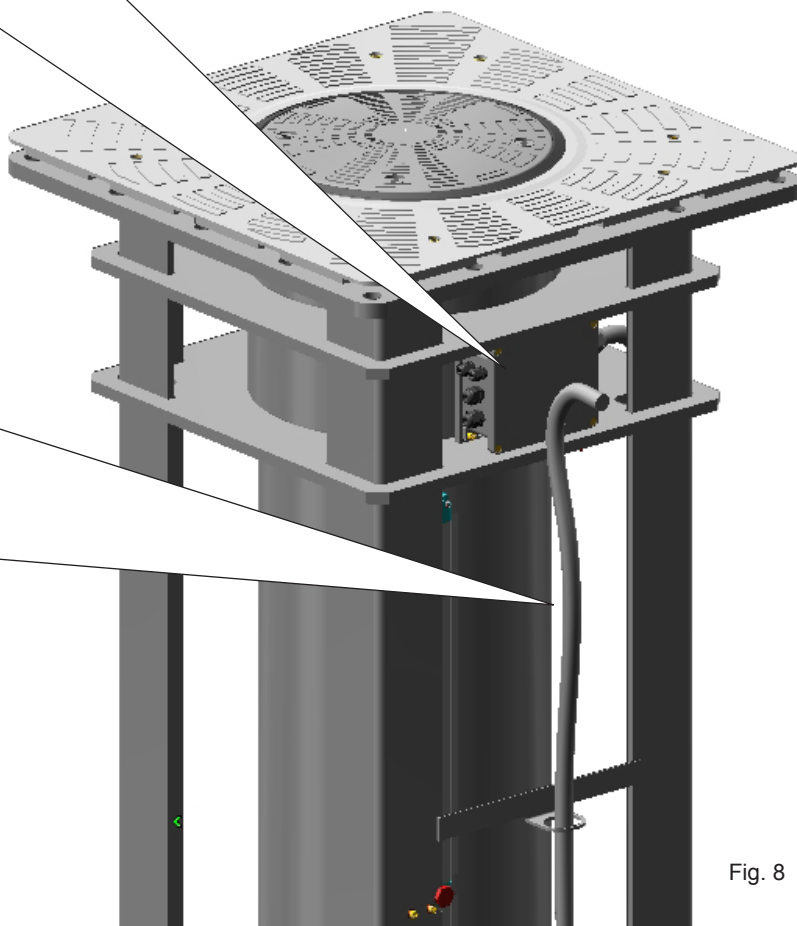
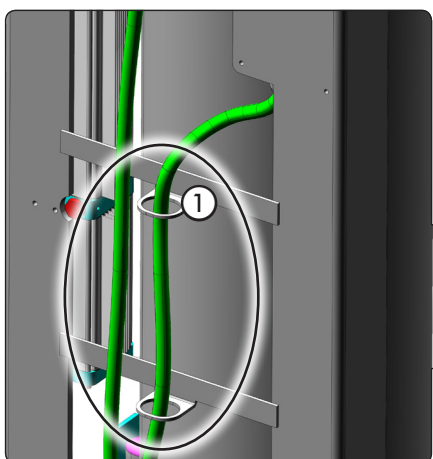
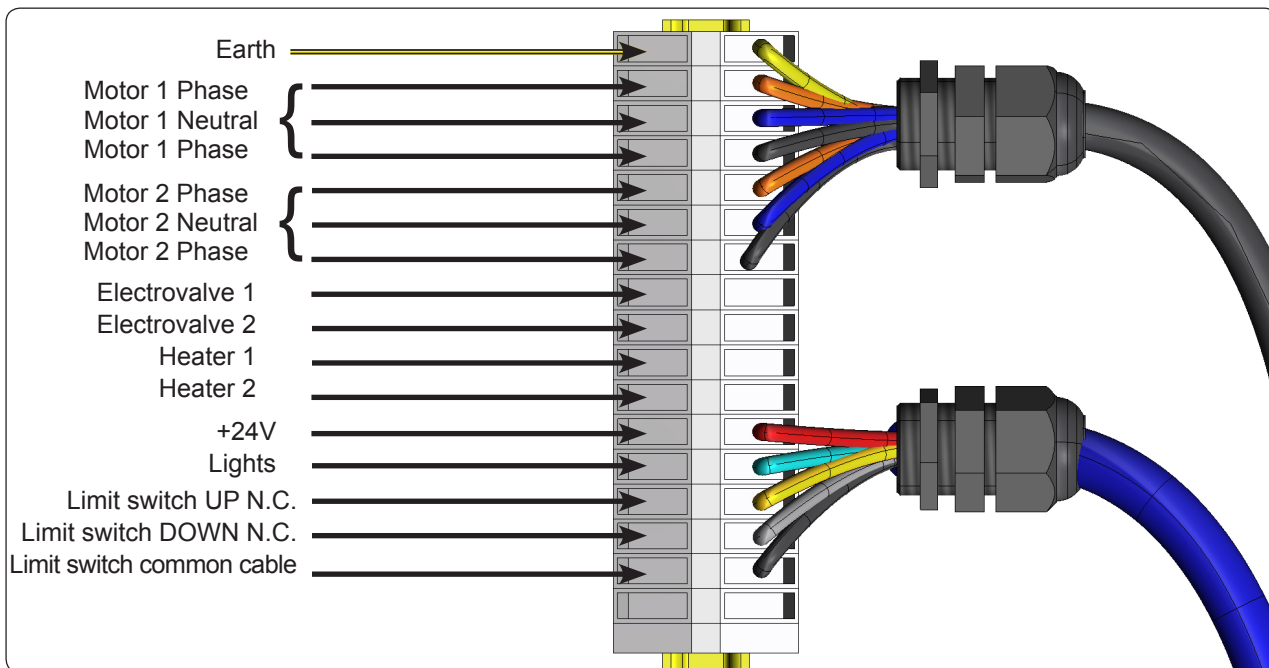



Fig. 8

6. INSERTING THE BOLLARD IN THE PIT

To place the bollard in the previously prepared pit (wait at least 7 days for the cement to set), you must screw two eyebolts M20 on the top part, as shown in the figure below, using them as hooking points for the lifting operation with belts or chains.

 **Before placing the bollard into the pit, check its correct operation and make sure that the safety devices operate correctly (see "JE275 CONTROL UNIT" at page 11).**

Lift and insert completely the bollard in the pit.

 **Take special care when positioning the cable between pit and bollard during the descent.**

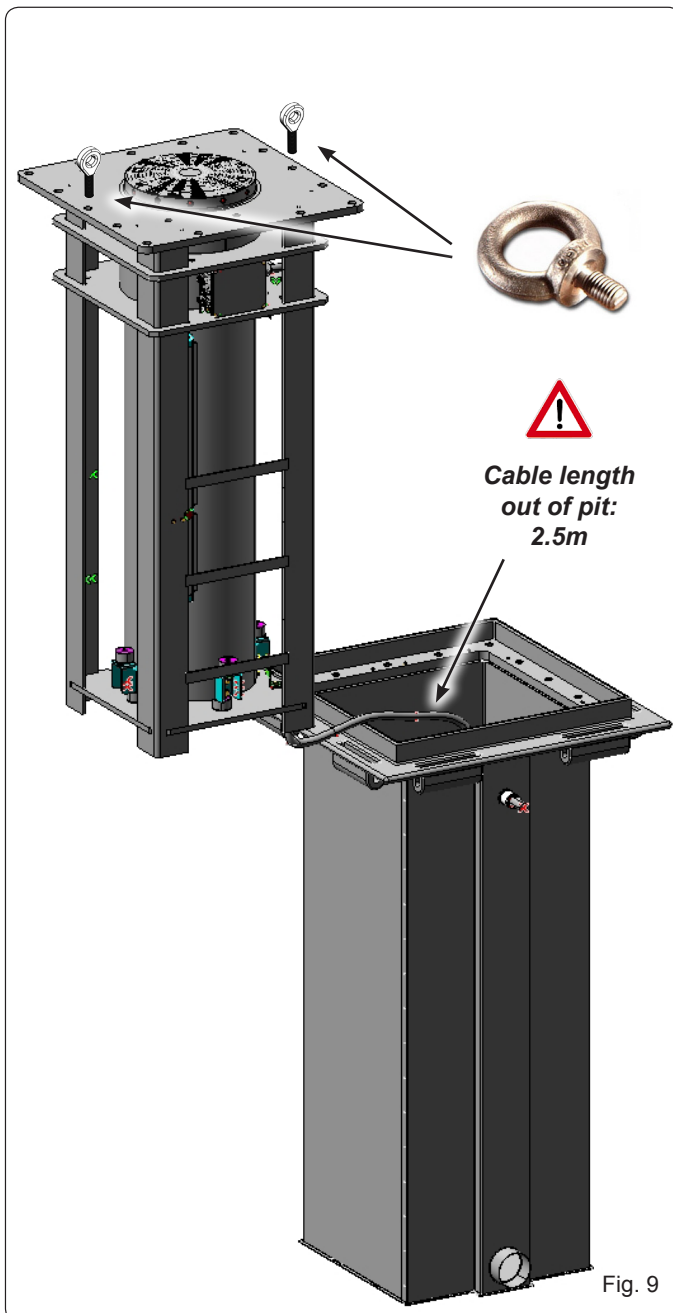

After completely inserting the bollard and resting it on the pit counter-frame, remove the two eyebolts and secure the bollard to the pit using the 15 provided cylindrical head screws with hexagon socket M20x45.

 **IMPORTANT:**
TIGHTEN THE 15 SCREWS USING 200Nm TORQUE

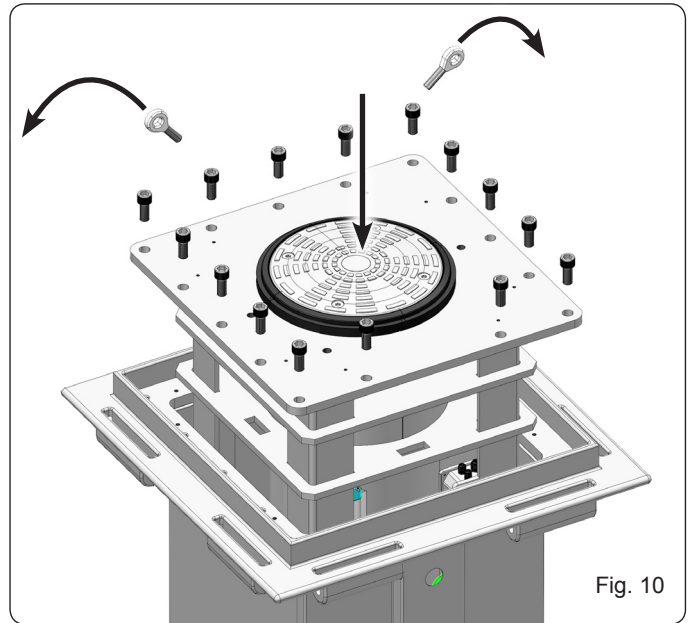

7. FASTENING THE TOP CROWN

After having secured the bollard, complete the installation positioning and securing the top crown with 8 cylindrical head screws with hexagon socket M8x30 INOX supplied standard

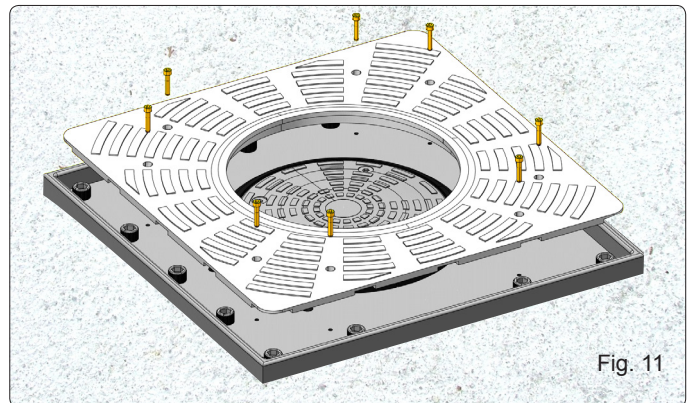

8. MANUAL OPERATION (OPTIONAL)

To manually lower the bollard, use the release device following the instructions below.

1. Loosen and remove the 8 cylindrical head screws with hexagon socket M8x30 securing the upper crown (Fig. 12 ref. ①).
2. Remove the upper crown (Fig. 12 ref. ②)
3. Insert a 5 mm tube key in the provided hole and turn anti-clockwise to lower the bollard (Fig. 12 ref. ③).

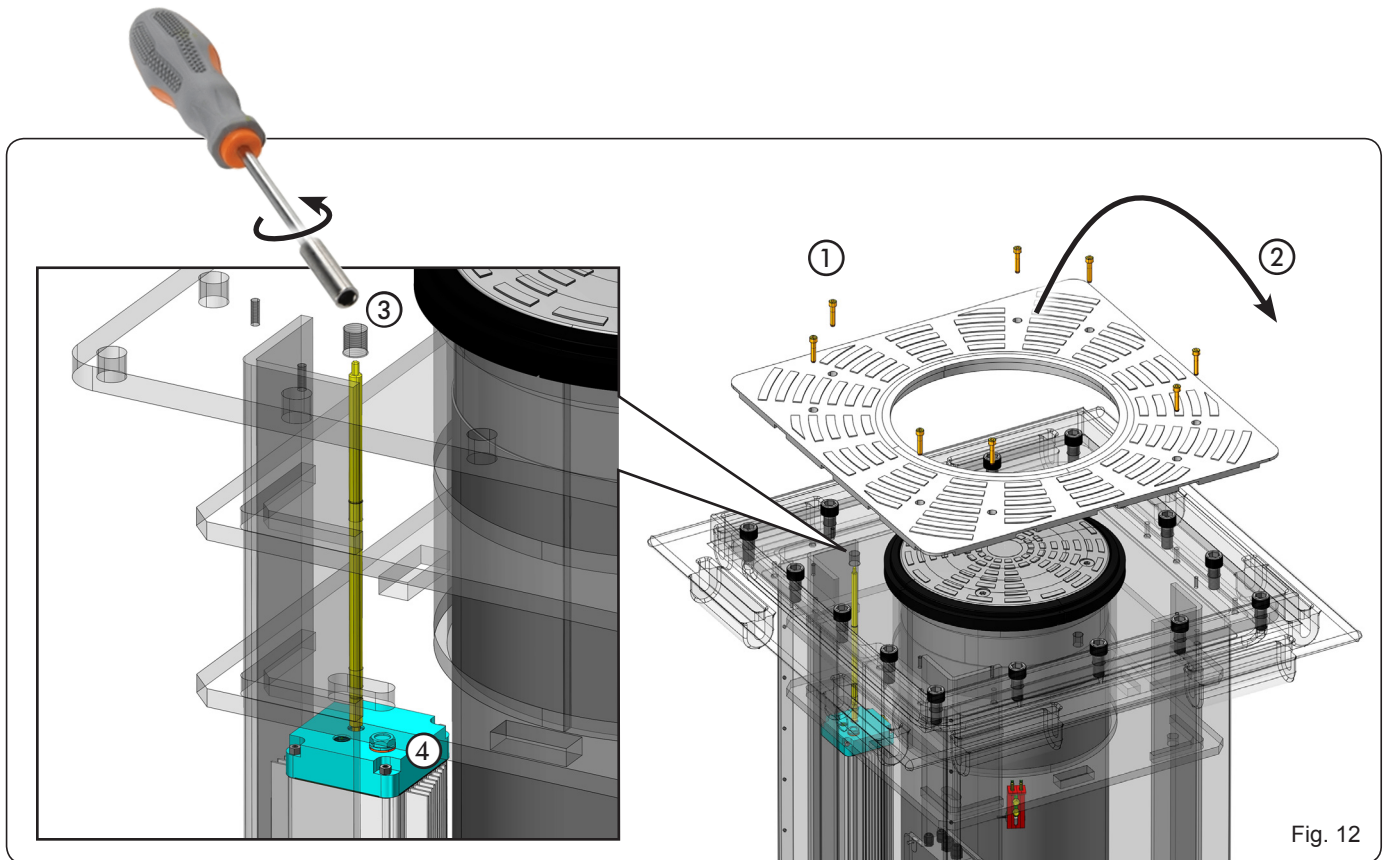

Fig. 12

9. AUTOMATIC OPERATION

To restore the automatic operation:

1. Insert a 5 mm tube key in the provided hole and turn clockwise until it stops, to lock the bollard.
2. Refit the upper crown.
3. Tighten the 8 cylindrical head screws with hexagon socket M8x30 securing the upper crown.

10. MAINTENANCE

The standard routine maintenance sequence is as follows:

1. Clean the pit using vacuum for deposited materials
2. Clean the drained water at the bottom of the pit
3. Check (and, if necessary, replace) the lower stop gaskets
4. Check and, if necessary, repair any oil leaks affecting the drive piston
5. Check that all the bollard screws are correctly tightened
6. Clean the drive cylinder and, if necessary, touch up the paintwork
7. Check the hydraulic unit; top up the oil, if necessary
8. Verify that the EFO system works correctly

JE275 CONTROL UNIT



- Always cut the power supply before performing any intervention on the control unit (connections, maintenance).
- Install a differential thermal-magnetic switch with suitable threshold (0.03A) upstream of the system.
- Connect the earth cable to the relevant terminal on the connector J9 of the unit (see figure below).
- Ensure that the grid disconnect switch has a lock key, unless it is installed in view of the operator/maintenance technician.
- The equipment must be laid at a height ranging between 0.4 m and 2.0 m.

11. ELECTRICAL CONNECTIONS

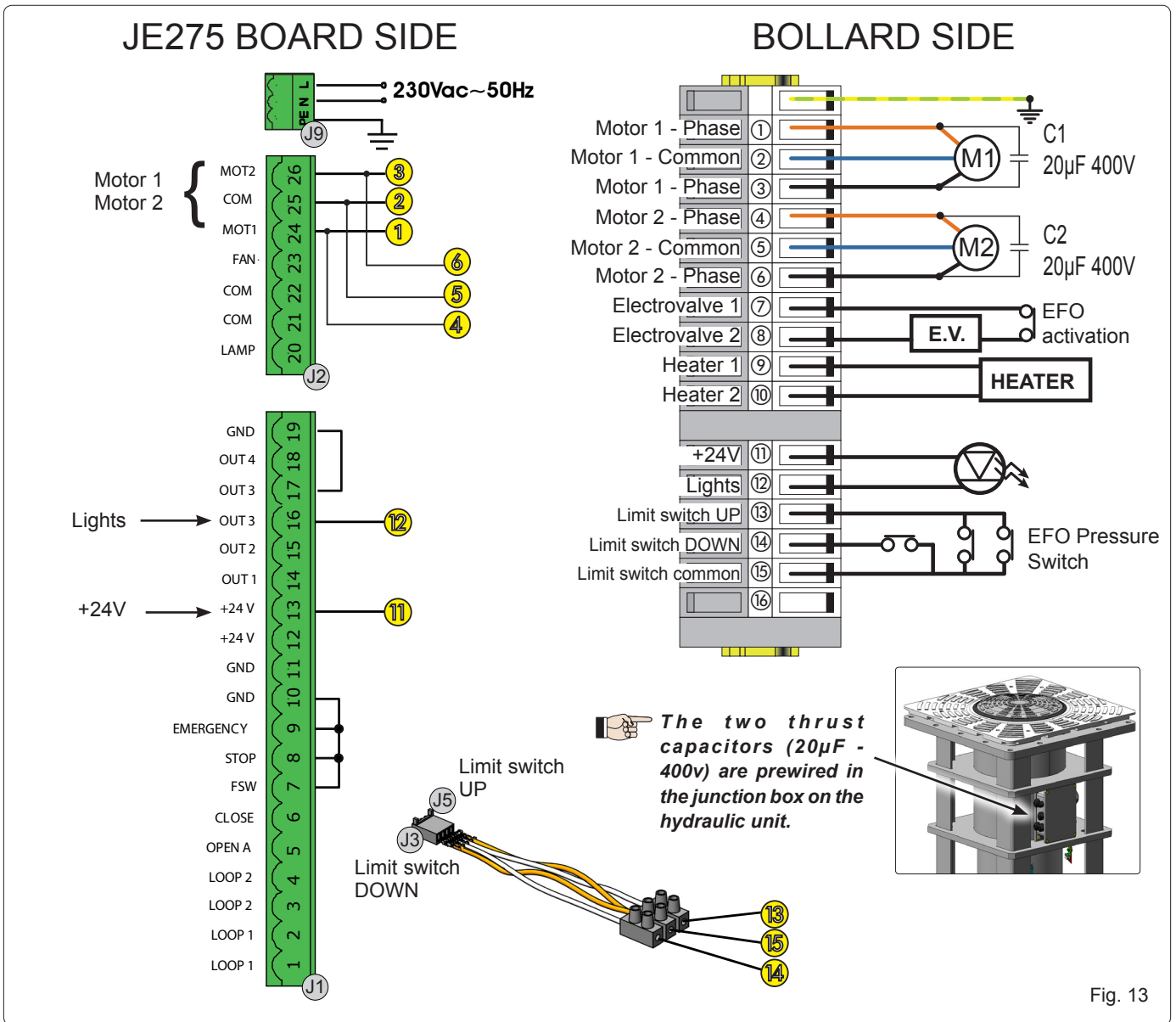

12. PRE-SETTING SELECTION

After having connected the board and after having supplied it with power according to the previous paragraph, you must select the work pre-setting for the bollard J355 M30-P1 following the operations below:

1. Enter the 1st level programming, holding down key F on the board. The initials dF will appear on the display
2. Release the F key and select 06 with the key +
3. Simultaneously press keys F and - to exit programming and save the changes performed.



For any further information on the unit programming, please refer to the relevant instructions.

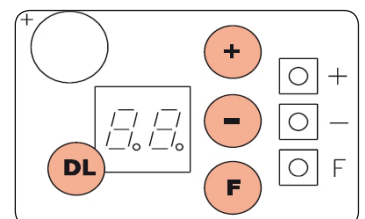

13. CONNECTING 2 BOLLARDS TO 2 JE275 BOARDS - MASTER-SLAVE CONNECTION

It is possible to simultaneously control 2 bollards by connecting 2 JE275 devices in MASTER-SLAVE configuration. Follow the instructions below for correct wiring and operation.

JE275 SLAVE

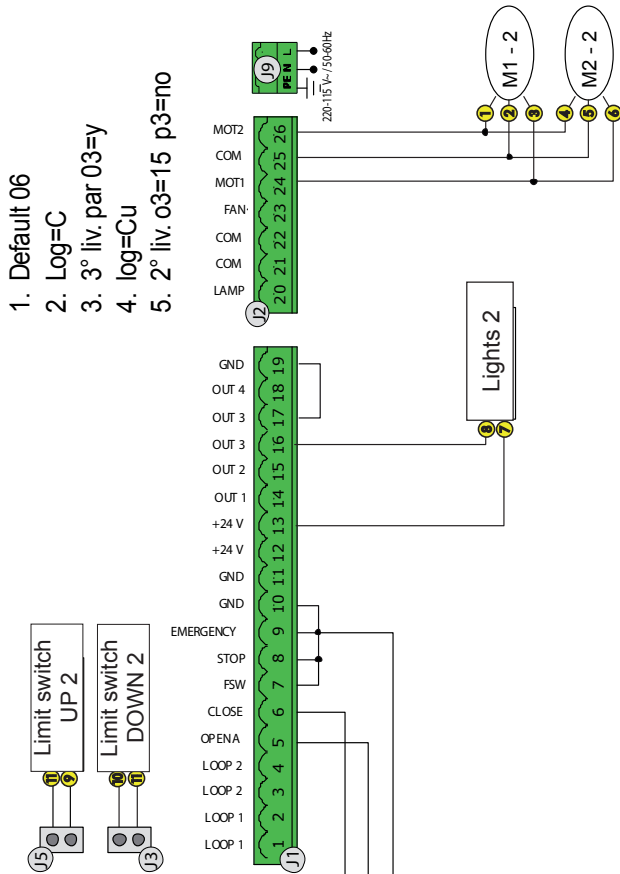

JE275 MASTER

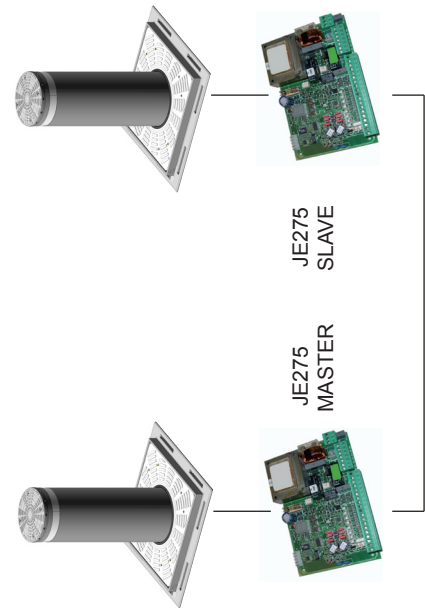
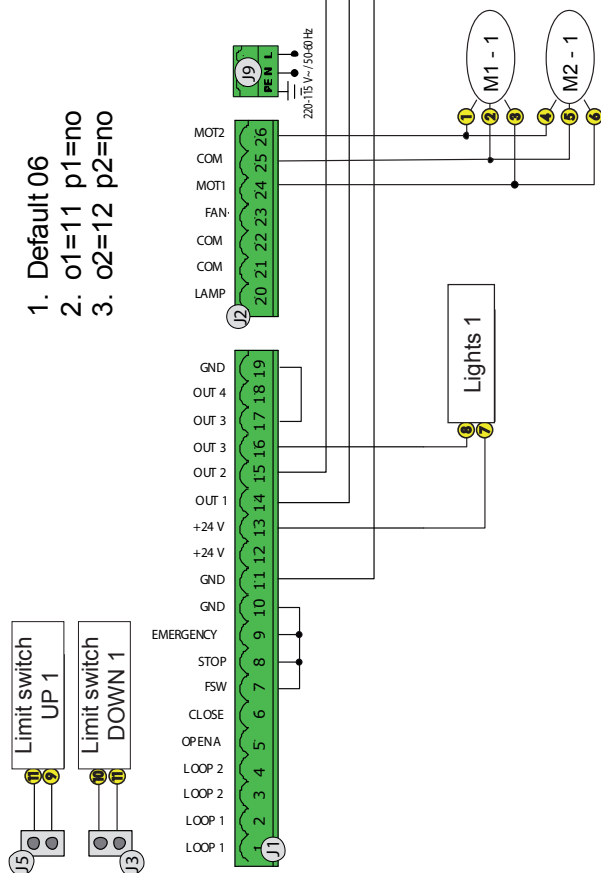

Fig. 14

14. TROUBLESHOOTING

The indications below will help you locate and solve particular conditions.

	CONDITION	ADVICE
1	The bollard does not rise, it remains down.	<ul style="list-style-type: none"> • make sure you have selected the default no. 6 on the JE275 board • check if the wiring of the solenoid valve was performed correctly, see par. 9 • Check the electrical wiring of the motor
2	The bollard remains up in closed position.	<ul style="list-style-type: none"> • make sure nothing between the cylinder and the sliding bush prevents the bollard movement • Check the electrical wiring of the motor
3	The LED flashing lamp does not operate	<ul style="list-style-type: none"> • make sure you have selected the default no. 6 on the JE275 board • check if the power connector under the head was fitted correctly.

15. PERFORMING MAINTENANCE ON THE EFO SYSTEM



The EFO system tank is always pressurised except when the system has just been activated. In the event of maintenance, prevent potentially dangerous situations by draining the oil from the EFO tank before performing any other operation.

Drain the oil by activating the EFO system by opening the contact between terminals 7 and 8 of the terminal block in the junction box and then **slowly** loosen the screw shown in figure 15, ref. ① and collect the oil in a container. Once maintenance is complete, top-up the hydraulic control unit once again with the previously drained oil by pouring it into the cap shown in Fig. 12, ref. ④.



The bollard is rapidly closed when the EFO is activated. Clear the relative area from objects and people in order to prevent dangerous situations

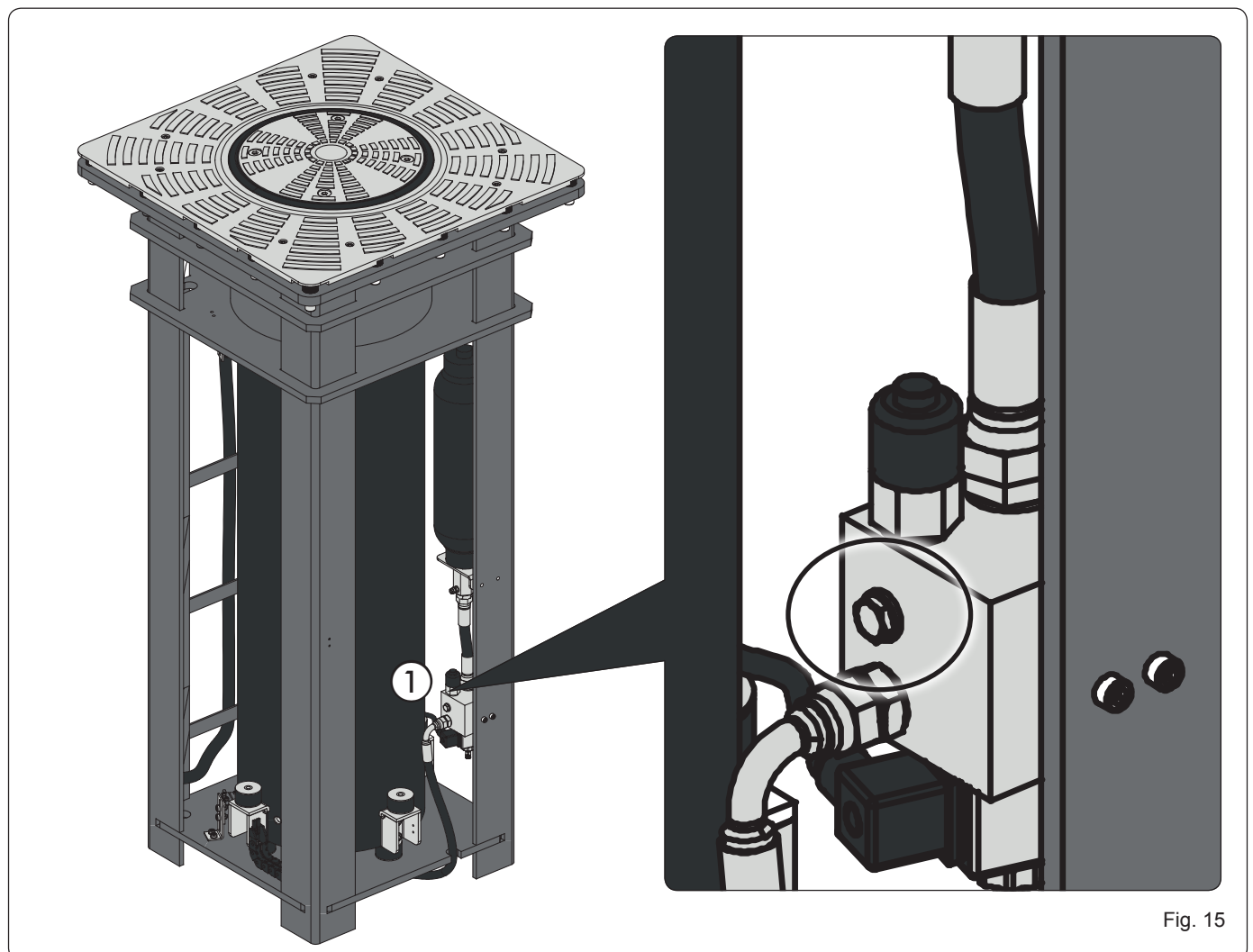

Fig. 15