

# J355HA M50

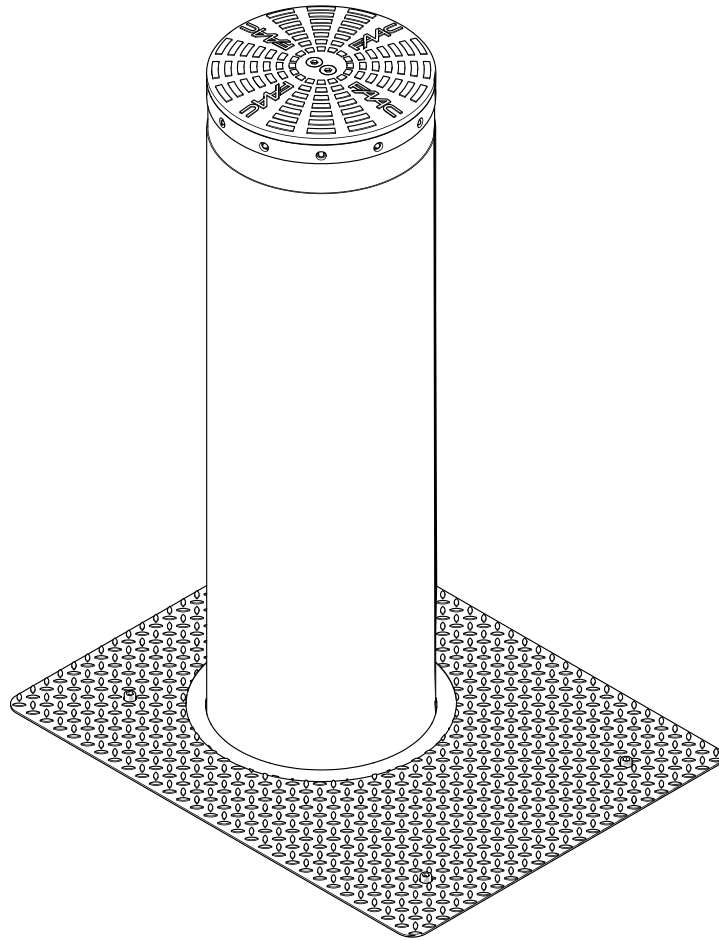

**FAAC**

Translation of the original instructions

# WARNINGS FOR THE INSTALLER

## GENERAL SAFETY OBLIGATIONS

1. **WARNING!** The following instructions must be read and followed in full in order to ensure the security and safety of individuals. Incorrect installation and/or incorrect use of the product could cause serious harm to people.
2. Read the instructions carefully before attempting to install the product.
3. The packaging materials (plastic, polystyrene, etc.) must not be left within reach of children as they are potential sources of danger.
4. Keep these instructions for future reference.
5. This product has been designed and built strictly for the use indicated in this documentation. Any other use that is not expressly specified in these instructions could affect the integrity of the product and/or represent a source of danger.
6. FAAC declines all liability deriving from misuse or any use other than that for which the automated system is intended.
7. Do not install the equipment in an explosive atmosphere: the presence of flammable gas or fumes represents a serious safety hazard.
8. FAAC is not responsible for failure to observe the rules of good technical practice during construction of motorised gates or closure devices, or for any damage which occurs during use of these.
9. Installation must be performed in compliance with Standards currently in force.
10. Before performing any operation on the system, disconnect the power supply.
11. The power mains of the automation system must be fitted with a multi-pole power switch with a switch-contact gap of at least 3 mm. It is advisable to use a 6A circuit breaker with a multi-pole power switch.
12. Ensure there is a residual current device with a 0.03 A threshold upstream of the system.
13. Check that the earthing system is constructed in accordance with the highest standards of workmanship and connect this to the metal parts of the gate.
14. The automated system is equipped with a built-in anti-crushing system consisting of a torque control device. It is nonetheless necessary to check the activation threshold, in accordance with the rules set out in point 10.
15. The safety devices (pursuant to standard EN 12978) protect any potentially dangerous areas against mechanical movement risks, such as crushing, dragging, shearing and lifting.
16. For each system, operators are advised to install at least one flashing light (e.g. integrated into the bollard head), as well as an adequately secured warning sign.
17. FAAC cannot be held responsible for any issue regarding the safety and correct operation of the device in any case in which components not produced by FAAC are used.
18. For maintenance, only original parts manufactured by FAAC must be used.
19. Do not modify the components of the automation system in any way.
20. The installer must supply all information relating to the manual operation of the system in case of emergency to the user.
21. Do not allow children or adults to remain near the product during operation.
22. Keep all remote controls or any other pulse generator out of the reach of children, to prevent the automated system from being activated involuntarily.
23. The bollard must only be crossed when the device is fully lowered.
24. The user must not attempt any kind of repair or any other form of direct operation on the device, and must only contact qualified personnel in order to do this.
25. Anything else not expressly specified in these instructions is not permitted.

## CONTENTS

<b>1. BOLLARD J355HA M50</b> .....	<b>4</b>
1.1 General instructions .....	4
1.2 Technical descriptions and specifications .....	4
1.3 Dimensions .....	5
<b>2. INSTALLATION</b> .....	<b>6</b>
2.1 Configuration .....	6
2.2 Construction of the foundation cage .....	7
2.3 Fixing the pit in place .....	8
2.4 Electrical wiring .....	10
2.5 Insertion into the pit .....	11
2.6 Fixing the top cover .....	11
2.7 EFO (Emergency Fast Operation - optional) .....	12
2.8 Manual operation (optional) .....	12
2.9 Automatic operation .....	12
2.10 Maintenance .....	12
<b>3. ELECTRONIC DEVICE JE275</b> .....	<b>13</b>
3.1 Electrical connections .....	13
3.2 board programming .....	14
3.3 Troubleshooting .....	14
3.4 Connecting several bollards (master/slave) .....	15

### EU DECLARATION OF CONFORMITY

The Manufacturer

**Company name:** FAAC S.p.A. Soc. Unipersonale  
**Address:** Via Calari, 10 - 40069 Zola Predosa BOLOGNA - ITALY

hereby declares on his sole responsibility that the following products:

**Description:** Automatic retractable bollard  
**Model:** J355HA M50

comply with the following applicable EU legislations:

2014/30/EU  
 2011/65/EU

Furthermore, the following harmonised standards have been applied:

EN61000-6-2:2005  
 EN61000-6-3:2007 + A1:2011

Bologna, Italy, 06-12-2019      CEO  
 A. Marcellan



# 1. BOLLARD J355HA M50



Please read this manual carefully. It accompanies the product, providing important information regarding safety, installation and use.

## 1.1 GENERAL INSTRUCTIONS

These instructions apply to the model

J355HA M50

This model refers to automatic hydraulic counter-terrorism traffic bollards. The cylinder is moved by a hydraulic unit inside the structure.

## 1.2 TECHNICAL DESCRIPTIONS AND SPECIFICATIONS

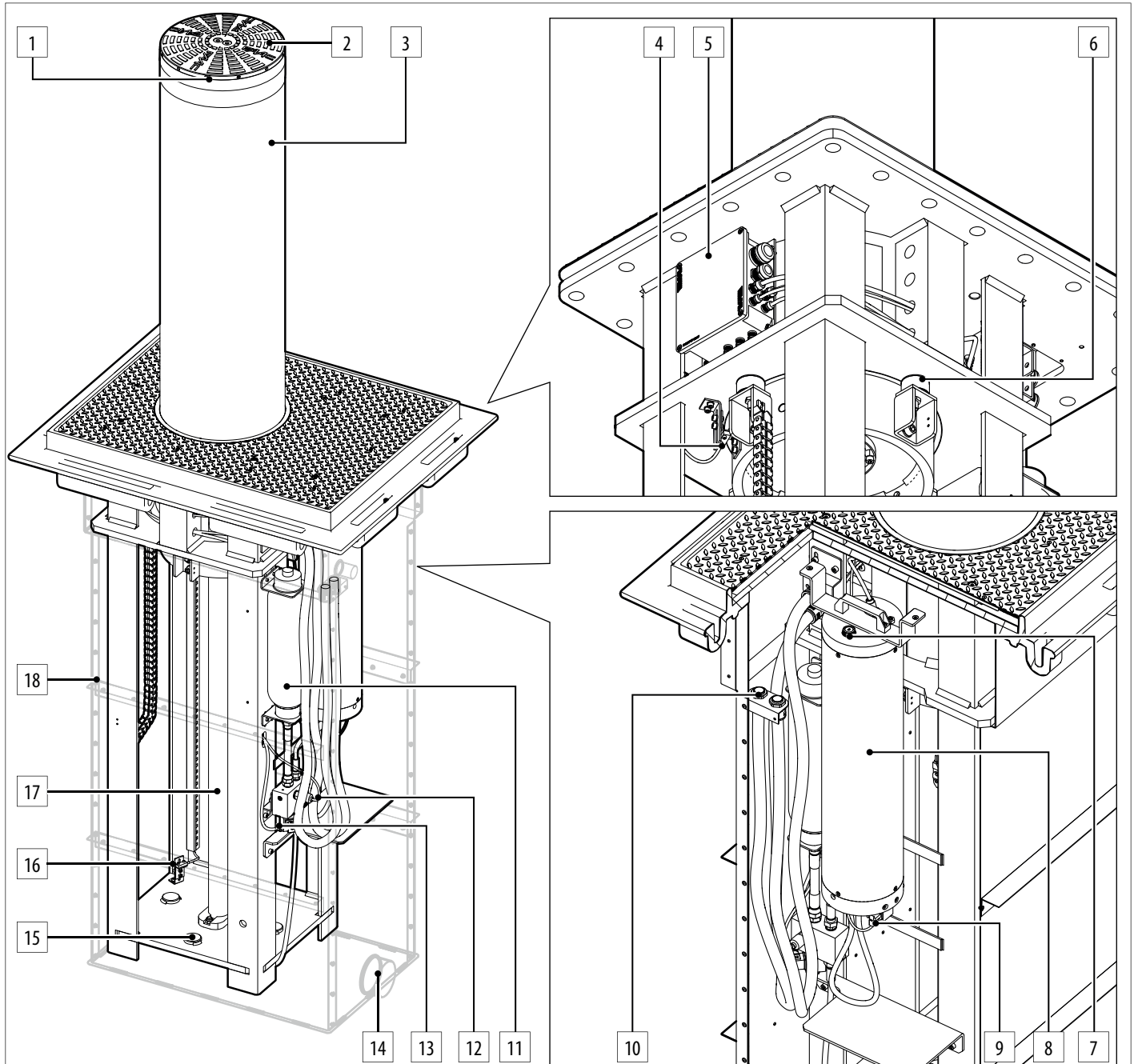

- |   |  |
|---|--|
| 1 Flashing LED                          | 10 Cable guides                                  |
| 2 Head                                  | 11 EFO accumulator                               |
| 3 Cylinder                              | 12 Pressure switch                               |
| 4 High position magnetic contact (N.C.) | 13 EFO solenoid                                  |
| 5 Junction box                          | 14 Ø 100 mm hole for drainage or pump connection |
| 6 4 stops devices, upper position       | 15 4 stops devices, lower position               |
| 7 Oil filler plug with dipstick         | 16 Low position magnetic contact (N.C.)          |
| 8 Hydraulic control unit                | 17 Plunger                                       |
| 9 Lowering solenoid valve               | 18 Foundation pit                                |

ENGLISH  
Translation of the original instructions

1 Table A - Technical specifications

MODEL	J355HA M50
Power supply	230 V~ (+6% -10%) 50 (60) Hz
Max. Power Consumption (W)	3900
Max. force (N)	9000
Maximum pump flow (lpm)	8
Minimum rise time (sec)	6
Minimum rise time (with EFO) (sec)	2
Minimum lowering time (sec)	2
Operating temperature (° C)	-15+55
Weight of bollard and pit (kg)	850 (bollard) 235 (pit)
Oil quantity (l) (1)	6 (standard version) 6.7 (EFO version)
Ingress protection	IP66
Size	See 2
Condenser (2)	50µF (70µF EFO) - 400V
Resistance to breakage (J) (3)	1852000



(1) Check the oil level using the dipstick positioned under the filler cap (1-7) with the piston rod fully inside and the EFO system under pressure.

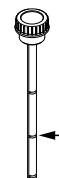

(2) The starting capacitor is pre-wired inside the junction box (1-5).

(3) certified according to PAS 68:2013 V/7500/[N3]/80/90 e IWA 14-1:2013 V/7200/[N3C]/80/90

1.3 DIMENSIONS

Dimensions in mm

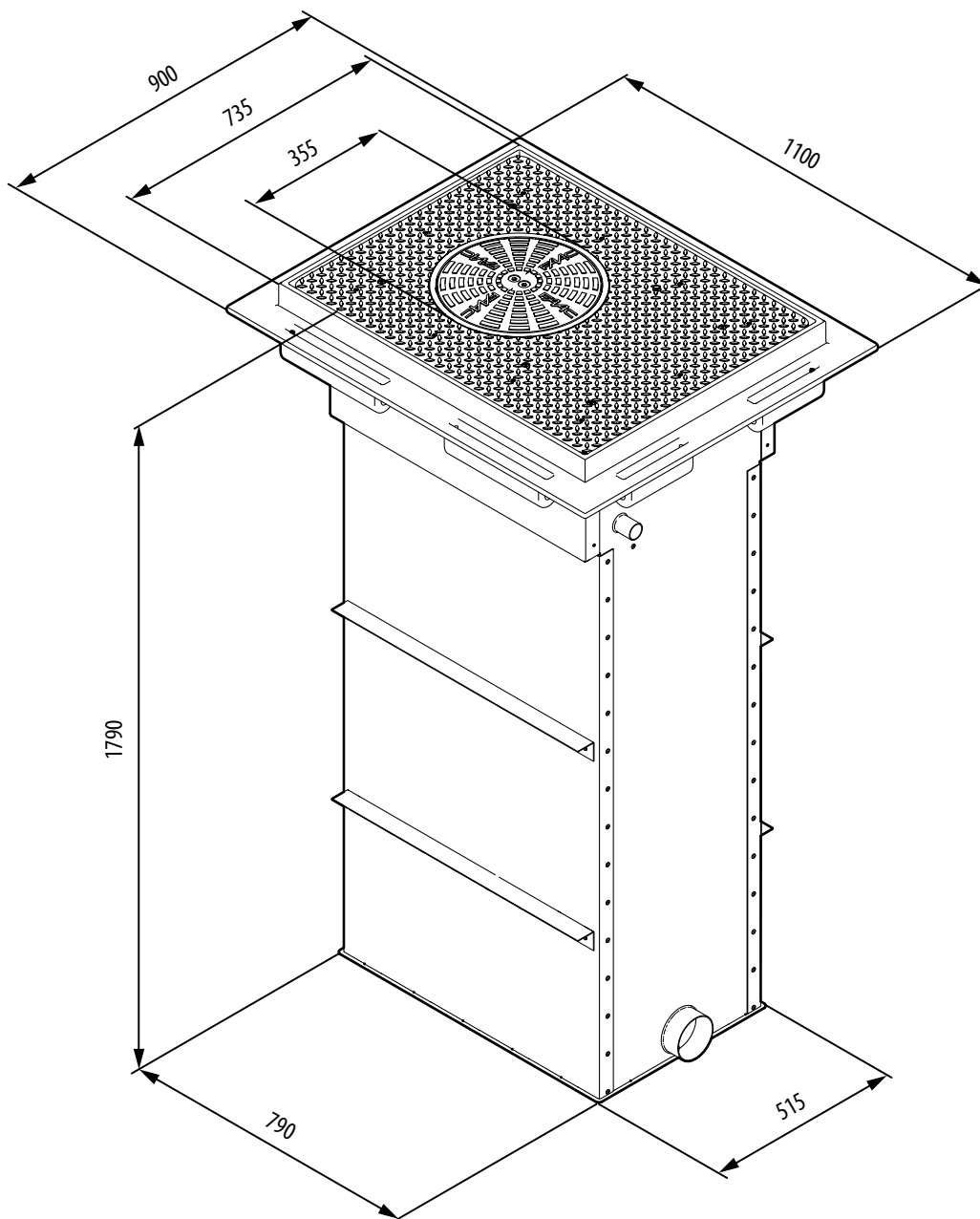

## 2. INSTALLATION

### 2.1 CONFIGURATION



A flexible hose with a diameter of  $\varnothing 100$  mm should be fitted for drainage. Dig the hole to a depth of approximately 1.85 m

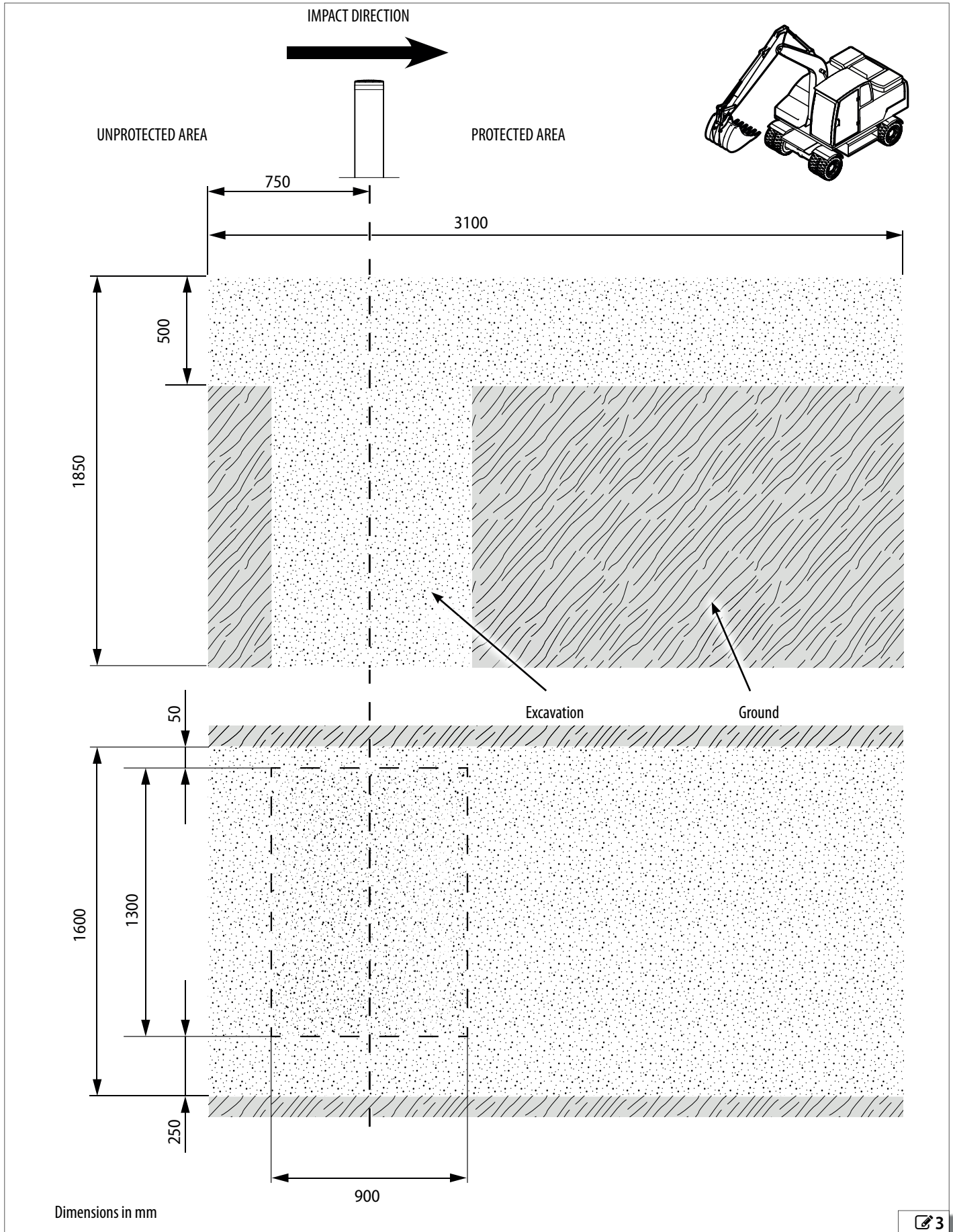

## 2.2 CONSTRUCTION OF THE FOUNDATION CAGE

Build the foundation cage (not supplied by FAAC) as shown in  4 using the Ø 12mm and Ø 20 mm iron rods - CLASS B450C

HS117EN

Translation of the original instructions

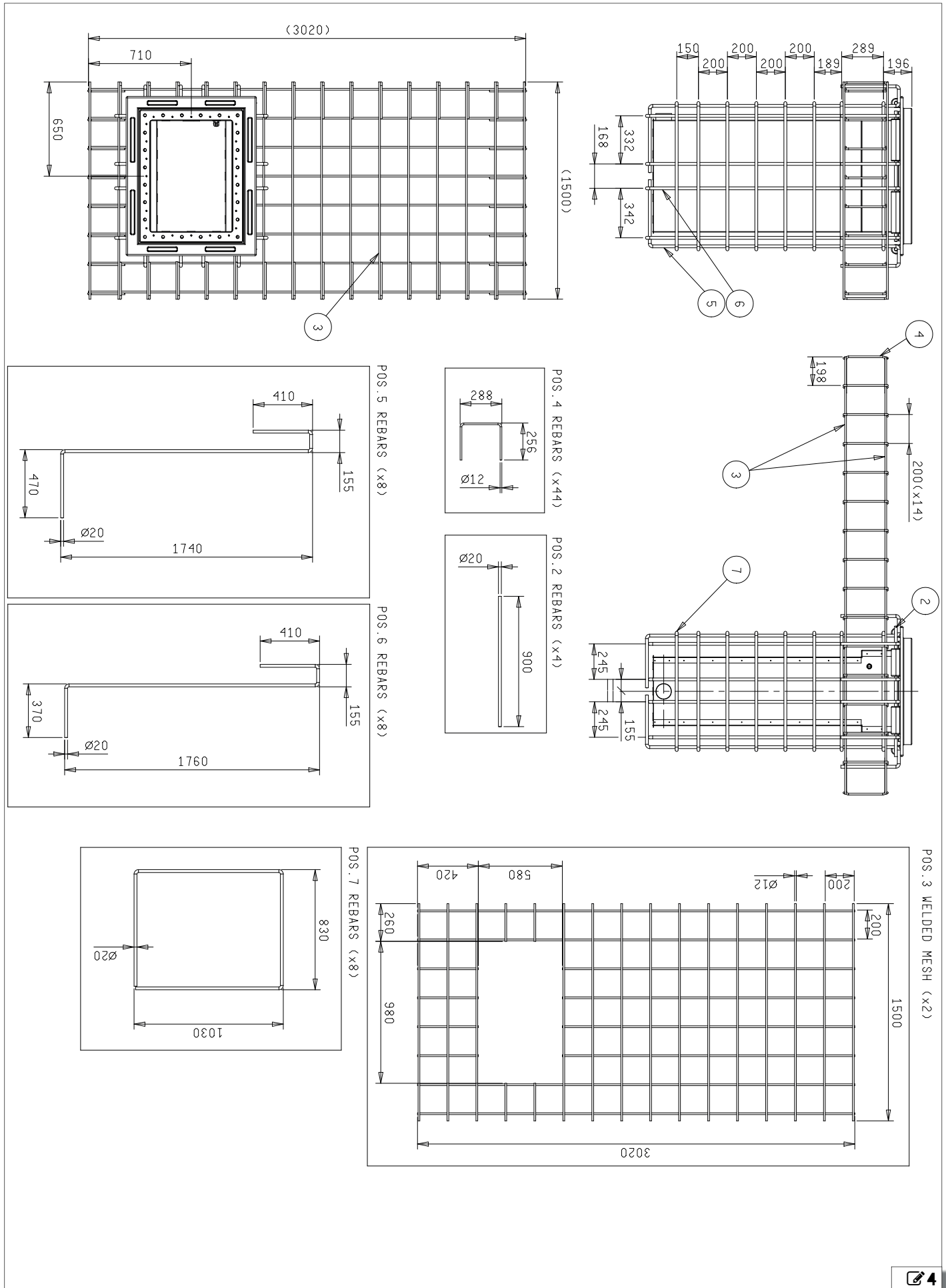

**2.3 FIXING THE PIT IN PLACE**

Once the foundation cage has been constructed, secure the counterframe to the pit plate with the M10x25 screws (☞5).

Then, position the pit inside the cage (☞6), and weld four 900 mm - Ø20mm (☞6-1) rods to the cage

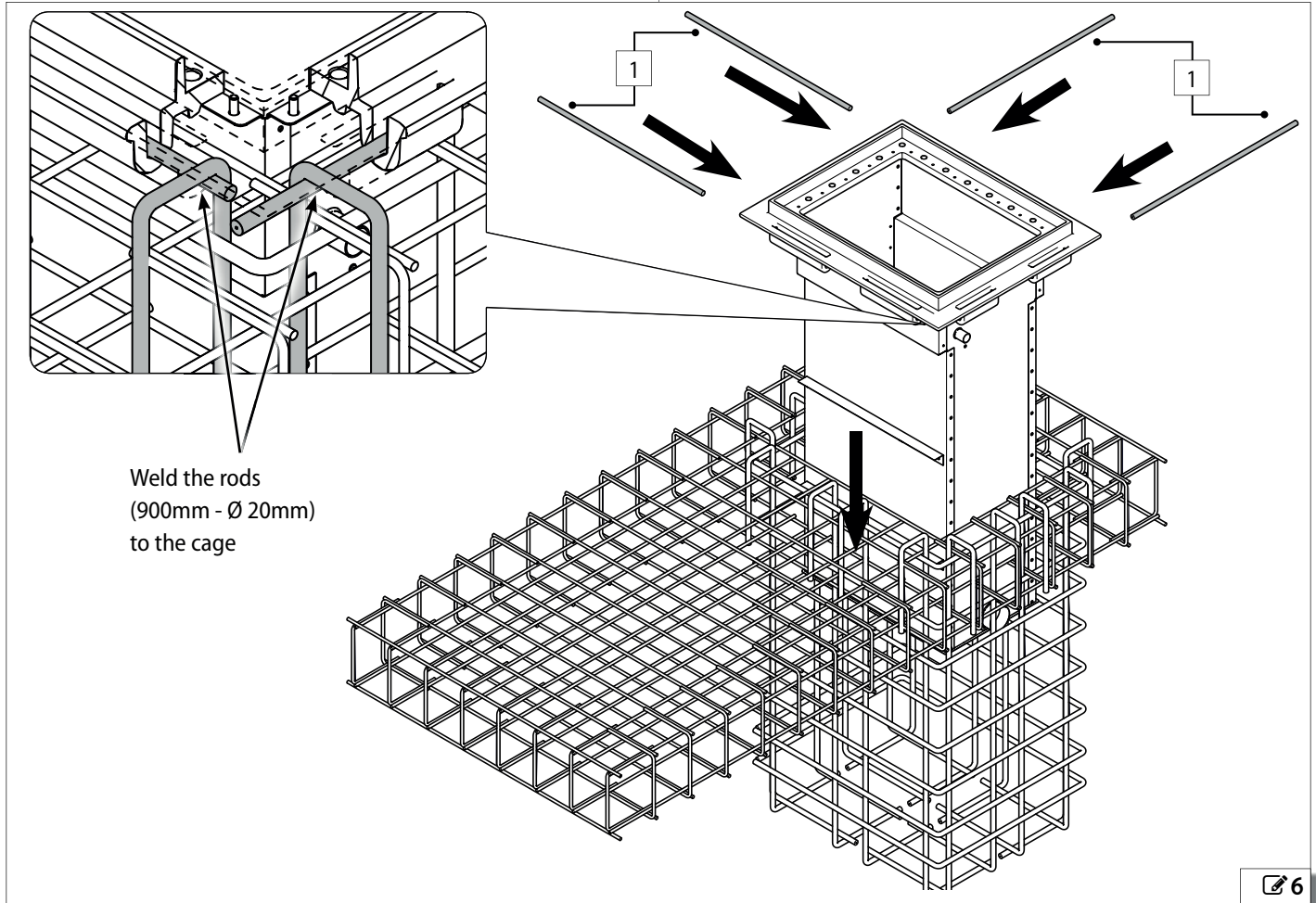
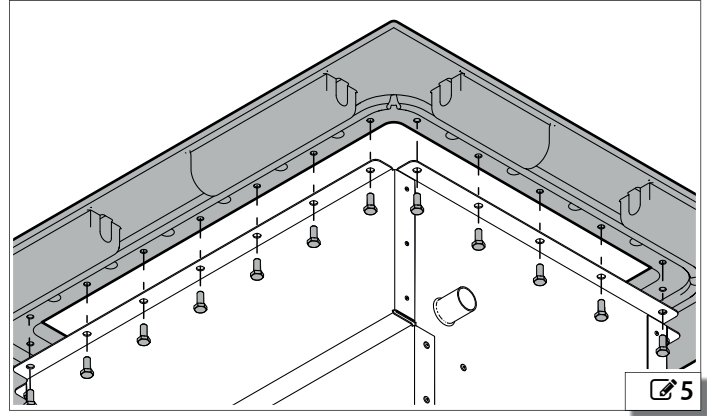

Weld the rods (900mm - Ø 20mm) to the cage



Lay the metal cage in the hole and plumb it in. In order to limit the entry of rain water into the pit, the upper level of the counterframe must be around 10mm higher than ground level, as shown to the left.

When the pit has been installed, lay one flexible sheath Ø50mm between the connections for this purpose inside the metal pit (☞1-10) and the electronic board (☞7).

Pour class C30/37 concrete around the cage to secure it properly, up to about 10 cm from ground level. Wait a minimum of 7 days to allow the concrete to cure properly.

Lay the piping necessary for connecting the bollard, the control board and any additional devices and finish the road surface with the same type of concrete.

N.B.: All piping must be laid in compliance with the applicable rules in force.

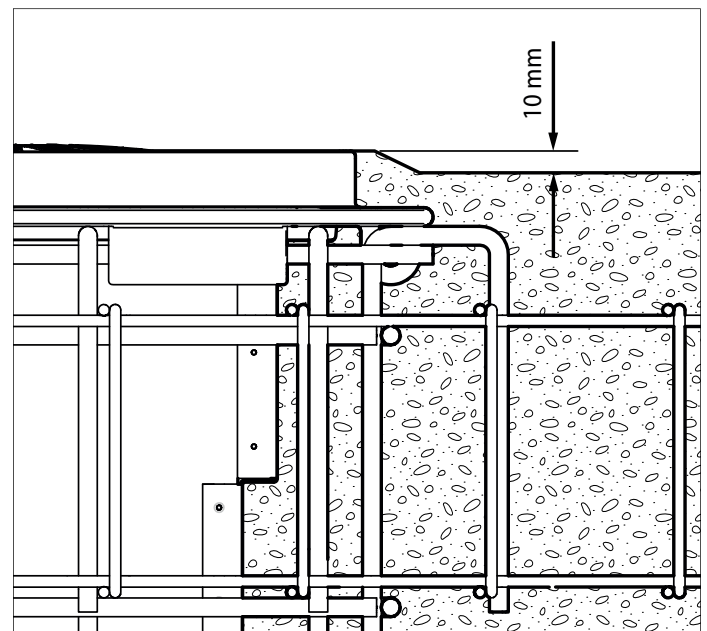



Whilst the concrete is curing, insert one or more of contrast supports inside the pit, to prevent the walls from bowing inwards due to the load of the fresh concrete.

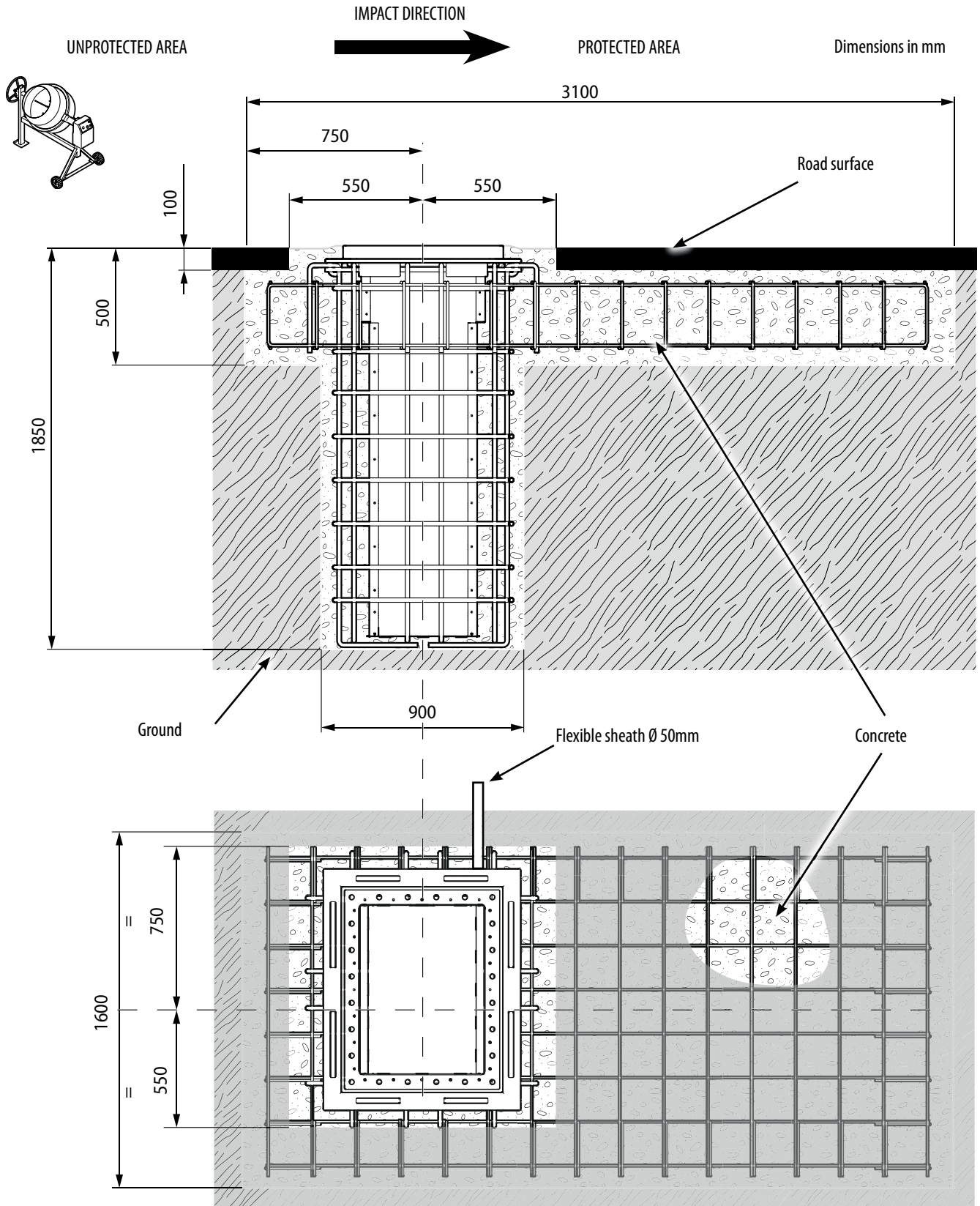

The foundation concrete can be poured directly into the excavated hole. Concrete specifications:

- Class C30/37.
- Concrete with aggregate 10-30 pursuant to UNI EN 12620
- The bollard must only be installed once the concrete has cured for at least 7 days.

The compaction index of the surrounding soil should be at least 90% of the optimal "Proctor" curve, pursuant to the UNI EN 13286-2: 2005 standard.

The steel reinforcement complies with the B450C class (ASTM A615 Grade 60).



## 2.4 ELECTRICAL WIRING



The contactor supplied with the bollard should be installed in the control board enclosure or in another suitable enclosure.

Use a type FG70R-0.6/1kV-16G1.5 (16 x 1.5mm<sup>2</sup> conductors) multi-polar cable to connect the bollard to the control board and a FG70R-0.6/1kV-3G4 cable (3 x 4 mm<sup>2</sup> conductors) to connect the bollard to the contactor, both of which should be a maximum of 50 metres long.

The cables must be laid inside a sheath of Ø50mm and passed through the cable guides provided on the pit sheet (8-1) and through the two corrugated conduits supplied with the pit.

Pass the wires through on the guides on the bollard frame as per as 8-2 then connect the corrugated conduits to the supports on the

bollard frame, as indicated in 8-3.

Complete the electrical connections in the terminal box at the side of the bollard as shown in 14.



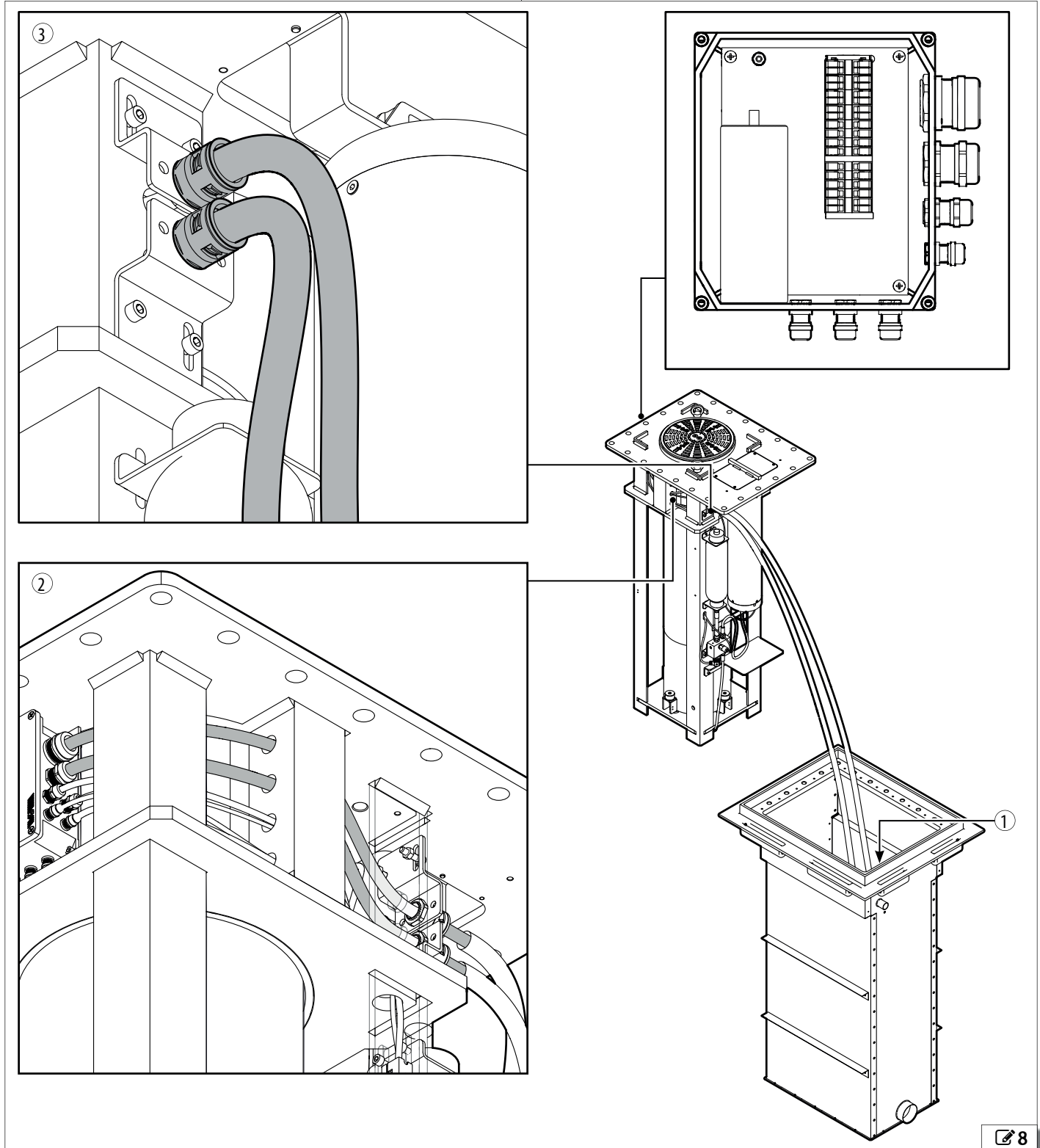

Any additional accessories (e.g. Open/close buttons, etc.) that are connected to the control board must be double insulated.



## 2.5 INSERTION INTO THE PIT

**i** Before inserting the bollard into the pit, complete the electrical connections as shown in §2.4 and §3.1, check that these function correctly, and also check the function of the safety devices (see "JE275 ELECTRONIC EQUIPMENT" §13).

In order to position the bollard in the pit (wait for at least 7 days for the concrete to cure), remove the safety bar, pulling the cotter pin out first  then the bar .

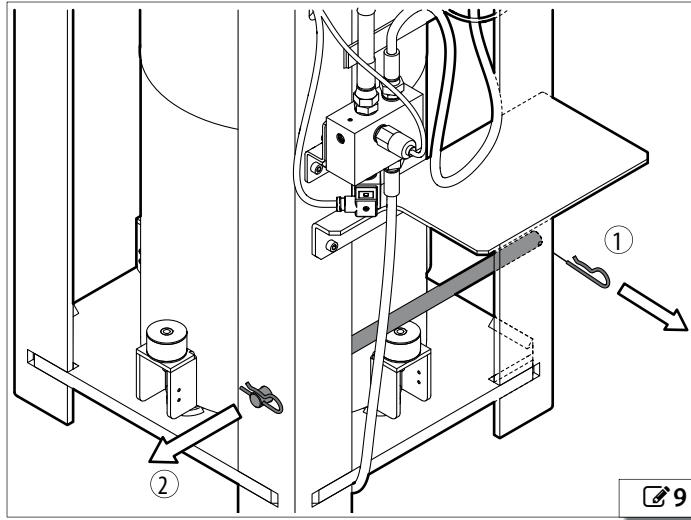

Screw the two male M20 eye bolts onto the upper part, as shown in , using them as hooking points for lifting with belts or chains. Raise the bollard and place fully into the pit.

**i** During this phase, take care to position the corrugated conduits correctly so that they are not pinched between the pit and the bollard frame

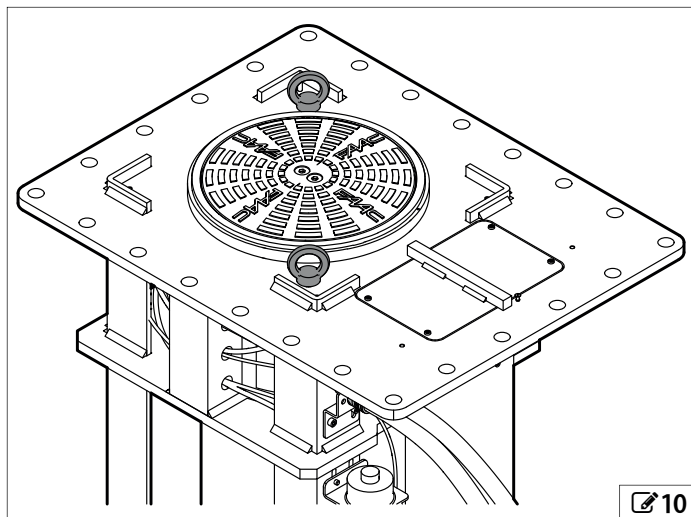

After you have fully inserted the bollard, resting it against the counterframe, remove the two eye bolts  and fix the bollard in place using the 24 TCEI M24x50 screws supplied with the pit.



**IMPORTANT:** Tighten the screws to a torque of **50Nm**

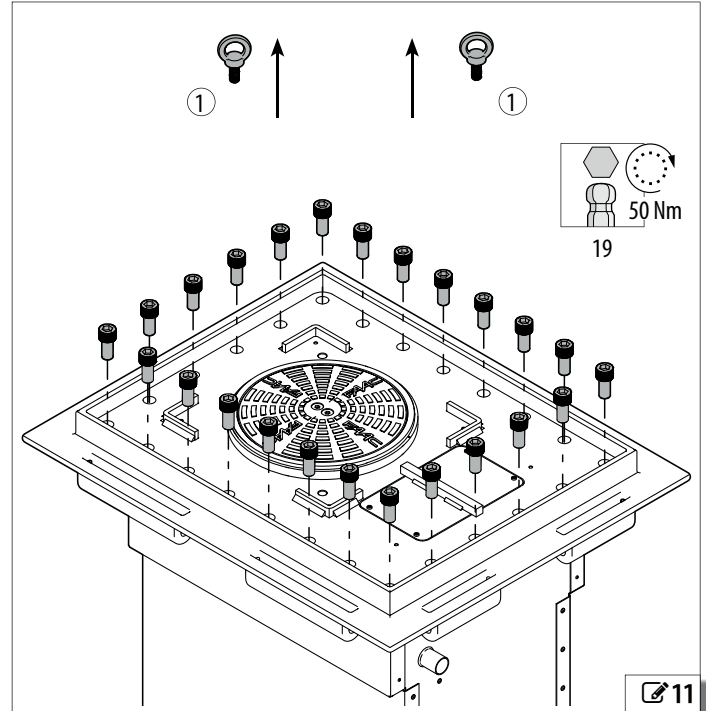

## 2.6 FIXING THE TOP COVER

After fixing the bollard in place, complete the installation by positioning and fixing the top cover with the six M8x40 steel screws provided.

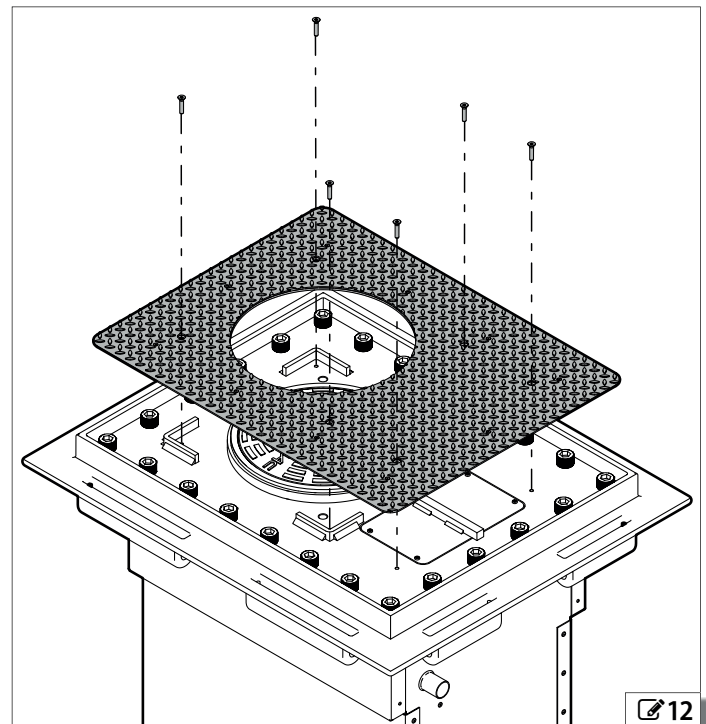

**2.7 EFO (EMERGENCY FAST OPERATION - OPTIONAL)**





The bollard J355HA M50 can be equipped with an EFO (Emergency Fast Operation) emergency activation system, which can be activated at any time to raise the cylinder immediately. The EFO system consists of a tank, a pressure switch and a solenoid control valve powered by 230V ~

In order to connect the solenoid valve (this varies depending on the N.O. / N.C. option adopted), refer to , terminals 4 and 5.

The N.O. solenoid valve ("Blackout" model) enables the EFO to be activated, both on the command of the operator and in the event of a power failure, while the N.C. version only allows for the voluntary activation of the device.





**2.8 MANUAL OPERATION (OPTIONAL)**

In order to manually lower the bollard, use the release device in accordance with the following guidelines:

1. Unscrew and remove the six M8x40 screws that secure the top cover in place (, 12).
2. Remove the top cover.
3. Unscrew and remove the four TORX T30 screws securing the cover of the hydraulic control unit in place (, 13-1).
4. Remove the cover of the hydraulic control unit.
5. Unscrew the lock nut , 13-2 and loosen the screw , 13-3 to move the cylinder downwards.

**2.9 AUTOMATIC OPERATION**

To restore automatic operation:

1. Turn the screw , 13-4 until the stop point in order to restore automatic operation.
2. Tighten the lock nut , 13-5
3. Reposition the hydraulic control unit cover and fix in position using the TORX T30 screws (, 13-1)
4. Reposition the top cover and fix in position using the M8x40 screws (, 12).

**2.10 MAINTENANCE**

The standard sequence of routine maintenance is as follows:

1. Clean the pit by sucking out any deposited material
2. Clean the water drainage systems at the bottom of the pit
3. Check and if necessary rectify any oil leaks from the movement piston
4. Carry out a general check to ensure that the bollard screws are correctly tightened
5. Carry out a general clean of the moving cylinder and touch up any paintwork
6. Check the hydraulic control unit, topping up the oil level
7. Check to ensure the EFO system is functioning properly

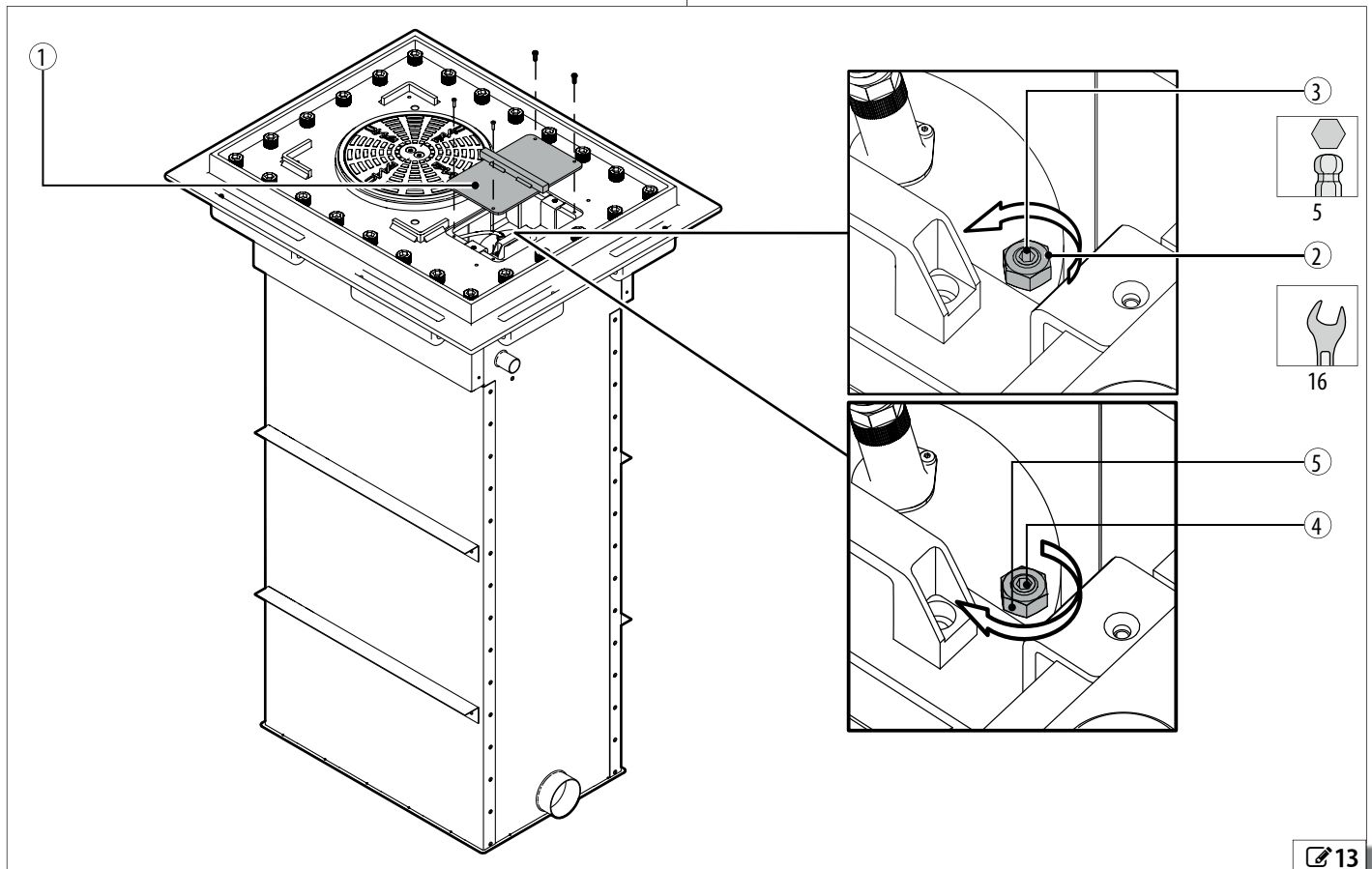

 13

### 3. ELECTRONIC EQUIPMENT JE275



Before performing any work on the electronic equipment (connections, maintenance), always turn the power off.

Install a differential thermal breaker upstream with adequate tripping threshold (0.03A).

Connect the ground cable to the terminal on the J9 connector on the equipment (🔗14).

Check that the mains switch is equipped with a locking key, unless this is fitted under the supervision of the operator/maintainer



The equipment must be installed at a height between 0.4 m and 2.0 m.

#### 3.1 ELECTRICAL CONNECTIONS

ENGLISH

Translation of the original instructions

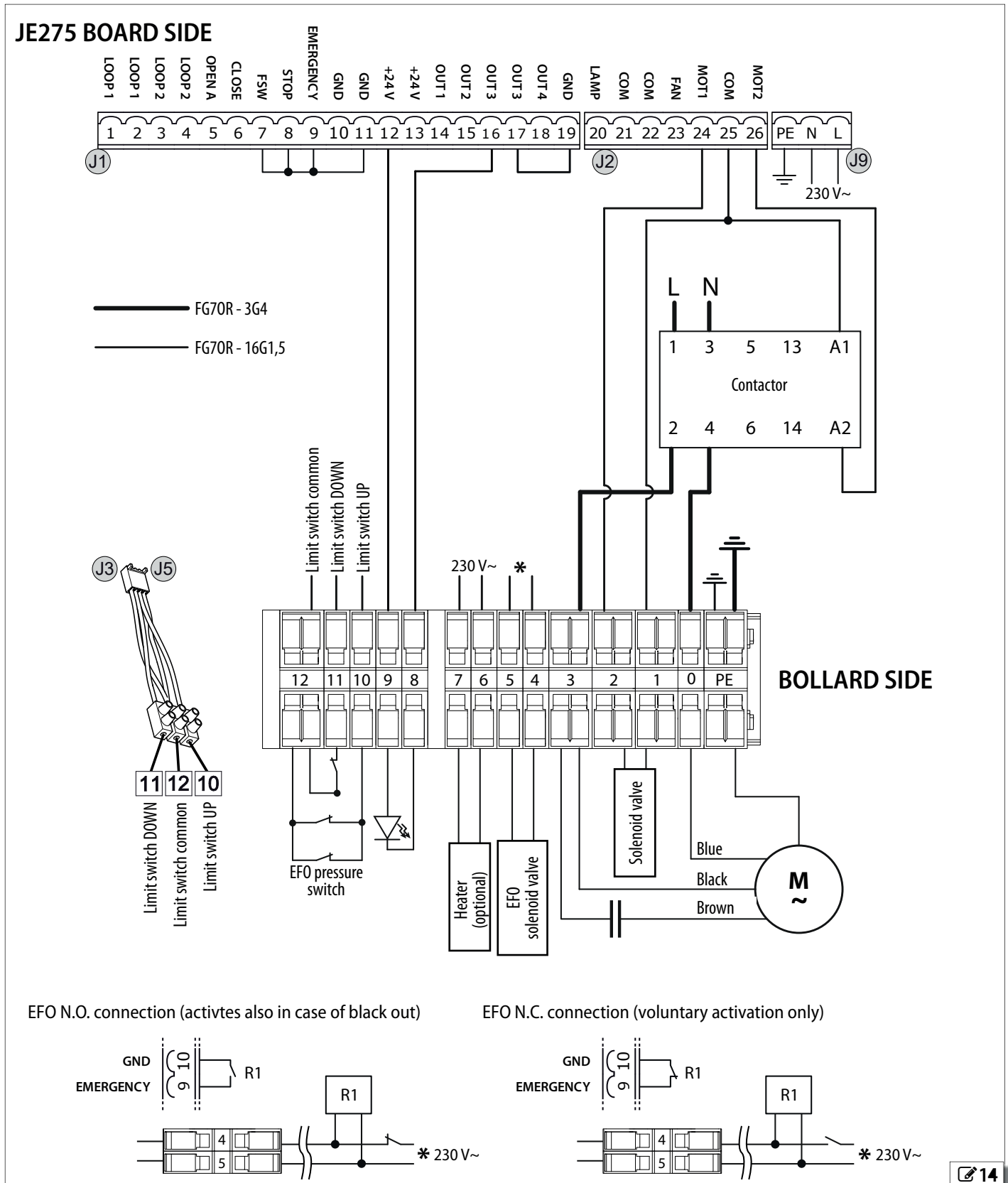

**3.2 BOARD PROGRAMMING**

After connecting and switching on the power to the control board as per the previous chapter, select the work pre-setting for the bollard J355HA M50 by performing the following operation:

1. Access level 1 programming by holding down the F button on the control board (15). The display will show the letters dF.
2. Release the F button and with the + button, select the value 06
3. Press the F button and hold it down whilst simultaneously pressing the – button to exit programming screen and save the changes made.
4. Press the F button and hold it down, as well as pressing + for around 10 seconds, until the display shows 01
5. Release the buttons, then press the F button scroll until you reach the b6 parameter
6. Set the value b6 = 4
7. Press the F button and hold it down whilst simultaneously pressing the – button to exit programming screen and save the changes made.



For more information on programming the equipment, please refer to the relevant instructions.

**3.3 TROUBLESHOOTING**

Below are a series of tips to help identify and solve a number of particular issues.

CONDITION	SUGGESTION
The bollard will not rise, it remains in the low position.	Check that you have selected default No. 6 on the JE275 control board Check that the bollard is set to automatic operation (S2.9) Check the wiring of the motor
The bollard will not lower, and remains in the high closed position.	Check that there is nothing between the cylinder and the slide bushing that is preventing movement Check the wiring of the motor
The flashing LED does not work	Check that you have selected default No. 6 on the JE275 (S3.2) control board Check that the power connector located under the head is properly inserted.

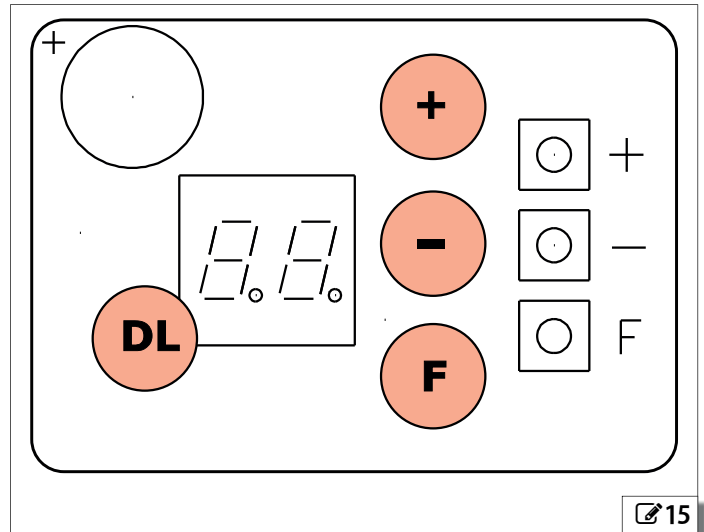

### 3.4 CONNECTING SEVERAL BOLLARDS (MASTER/SLAVE)

You can operate more than one bollard simultaneously, and these can be interconnected using the corresponding JE275 device in the MASTER-SLAVE configuration. Follow the following guidelines for proper wiring and operation of the devices.

## JE275 MASTER

1. dF = 06
2. o1 = 11  
P1 = no  
o2 = 12  
P2 = no
3. 10s  
b6 = 4

## JE275 SLAVE

1. dF = 06  
LO = C
3. 10s  
O3 = 4
4. LO = Cu

